

TM 3-4230-237-10

TECHNICAL MANUAL

OPERATOR'S MANUAL FOR

DECONTAMINATING APPARATUS: DIESEL ENGINE-DRIVEN (DED), SKID-MOUNTED, 500-GALLON, M12A1

NSN 4230-01-502-7224 (EIC 5FB)

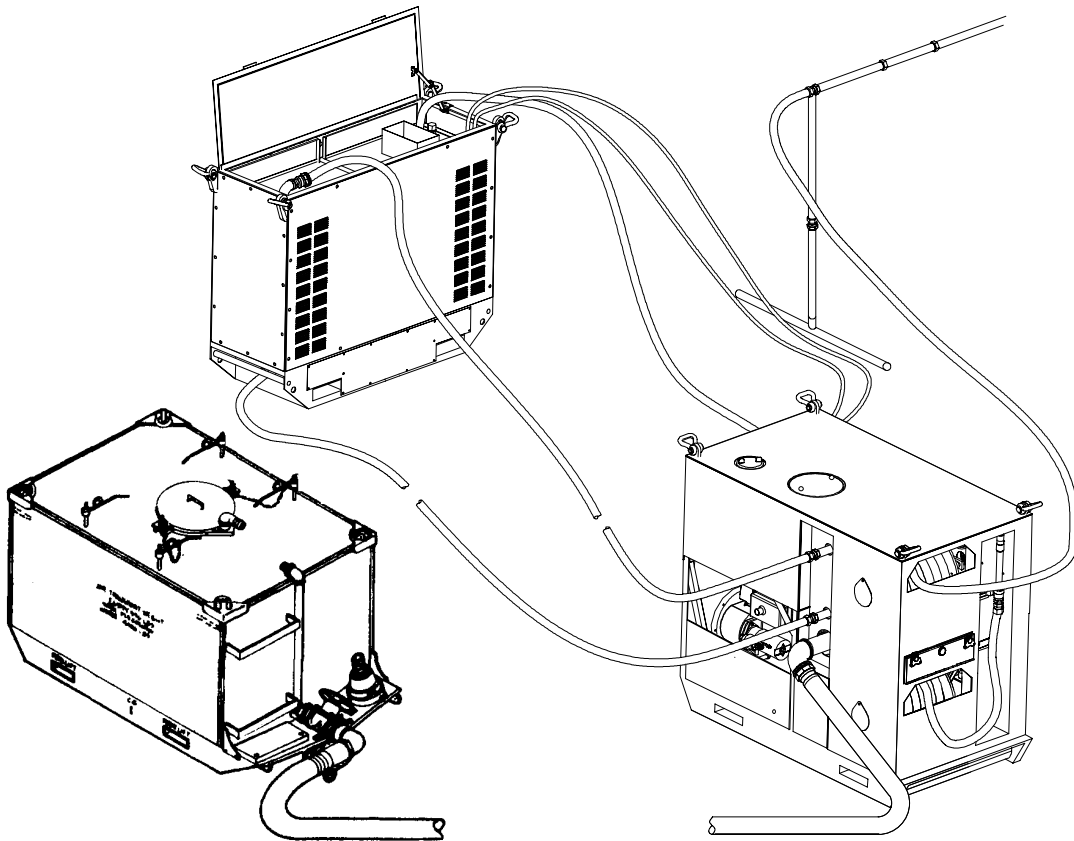

DISTRIBUTION STATEMENT A: Approved for public release; distribution is unlimited.

HEADQUARTERS, DEPARTMENT OF THE ARMY
30 NOVEMBER 2003

WARNING SUMMARY

WARNING **DEATH OR SEVERE INJURY MAY RESULT IF PERSONNEL FAIL TO OBSERVE WARNINGS**

Remove all jewelry before starting work. Metal objects such as rings or tools can cause short circuits. Do not allow tools to contact live circuits. A direct short can cause instant heating of tools resulting in equipment damage and personnel burns. Failure to comply may result in personal injury.

DANGEROUS CHEMICALS, DIESEL FUEL, HIGH VOLTAGE (maximum 24 volts), and SCALDING WATER are used in the operation of the equipment. CARBON-MONOXIDE is present in the exhaust gases of the engine and the water heater.

Wear protective clothing and a mask when engaged in decontaminating operations. STB decontaminating agent and slurry are harmful to the skin, eyes, lungs, and clothing. If STB decontaminating agent or slurry gets into the eyes, flush them immediately with clear water. If STB decontaminating agent or slurry is taken internally, drink raw egg white, milk, rice gruel, or milk of magnesia. Do not induce vomiting. Seek medical assistance immediately. If STB decontaminating agent or slurry contacts the skin, wash off immediately with clear water.

When engaged in decontaminating operations, protective clothing and mask must be worn. When mixing, blending, or spraying sodium hydroxide solution, personnel must wear full rubber protective clothing, gloves, boots, and mask. Avoid contact with the skin and eyes. Avoid breathing the dust.

Wear hearing protection when operating the decontaminating apparatus.

An operator must be in attendance at all times during operation of the water heater. Water must be circulating through the water heater before fuel is ignited, as well as throughout the time the water heater is operating.

Insure that the main power cable is disconnected from the power source prior to performing inspection and servicing of electrical motors, control box, and rotating parts of the water heater.

Make certain that the fuel supply and fuel return lines are properly connected before operating the water heater.

Wear eye protection and protective gloves when fueling the decontaminating apparatus.

Authorized fuel will be obtained only from authorized fuel services or fuel trucks. Siphoning fuel from vehicles is prohibited. Siphoning can cause static electricity, mouth and throat damage, and lead poisoning.

When operating tank drain valve, be careful to prevent injury to fingers.

Use caution when opening drums of Super Tropical Bleach (STB); wear protective clothing and mask. Avoid contact with skin or eyes. Avoid contamination with acids and oxidizable materials such as fuels, oils, paint products, disinfectants, and ammonia. Such contamination can cause release of hazardous gases. Keep container closed and stored in a cool dry place. Mix only in accordance with directions for use. In case of contact with skin or eyes, immediately flush continuously with water; for eyes get medical attention.

Keep clear of the exhaust stack during operation of the water heater.

The battery and battery compartment may be coated with acid caused by spillage or fumes. Wear protective clothing and eye protection while working in this area. Wash your hands with baking soda and water solution; flush with clear water before eating, smoking, or touching your face or clothing. If battery acid splashes into your eyes, flush them out using clear water and obtain medical treatment immediately. Failure to do so may cause blindness.

Inspect the fuel tank in daylight. If a light is required, use a vapor-proof light. Do not permit open flames, sparks, smoking, or heated objects in the area during fueling.

The engine and water heater exhausts are lethal. Do not inhale these gases. A chemical-biological mask does not protect against carbon monoxide. When the decontaminating apparatus is to be operated, the exhaust gases must be vented away from the operator and outside of an enclosed area to prevent carbon monoxide poisoning.

To avoid injury or electrical shock, keep the HEATER RECEPTACLE AND SWITCH on the pump unit control panel to OFF when the water heater is not in use. Avoid contact with the battery's positive contact at the starter solenoid when adjusting the belt tension. Electrical shock or damage to the equipment may result.

When disconnecting the hoses with the water temperature at or above 100°F (38°C), exercise extreme care to prevent scalding.

Fire and explosion danger exist when solvent cleaning compound is used. Make sure that equipment is dry before operating.

For additional first aid data see FM 4-25.11.

LIST OF EFFECTIVE PAGES/WORK PACKAGES

Date of issue for the original manual is:

Original: 30 November 2003

TOTAL NUMBER OF PAGES FOR FRONT AND REAR MATTER IS 16 AND TOTAL NUMBER OF WORK PACKAGES IS 28, CONSISTING OF THE FOLLOWING:

| Page/WP No. | *Change No. | Page/WP No. | *Change No. |
|---------------------|--------------------|----------------------|--------------------|
| Cover | 0 | Chp 3 title page | 0 |
| Warnings | 0 | WP 0013 00 (2 pgs) | 0 |
| A/B blank | 0 | WP 0014 00 (10 pgs) | 0 |
| i-iv | 0 | Chp 4 title page | 0 |
| Chp 1 title page | 0 | WP 0015 00 (2 pgs) | 0 |
| WP 0001 00 (4 pgs) | 0 | WP 0016 00 (22 pgs) | 0 |
| WP 0002 00 (6 pgs) | 0 | WP 0017 00 (8 pgs) | 0 |
| WP 0003 00 (2 pgs) | 0 | WP 0018 00 (10 pgs) | 0 |
| Chp 2 title page | 0 | WP 0019 00 (26 pgs) | 0 |
| WP 0004 (14 pgs) | 0 | WP 0020 00(4 pgs) | 0 |
| WP 0005 00 (3 pgs) | 0 | WP 0021 00 (2 pgs) | 0 |
| WP 0006 00 (10 pgs) | 0 | WP 0022 00 (2 pgs) | 0 |
| WP 0007 00 (14 pgs) | 0 | WP 0023 00 (2 pgs) | 0 |
| WP 0008 00 (24 pgs) | 0 | WP 0025 00 (2 pgs) | 0 |
| WP 0009 00 (8 pgs) | 0 | Chp 5 title page | 0 |
| WP 0010 00 (6 pgs) | 0 | WP 0026 00 (2 pgs) | 0 |
| WP 0011 00 (2 pgs) | 0 | WP 0027 00 (4 pgs) | 0 |
| WP 0012 00 (4 pgs) | 0 | WP 0028 00 (4 pgs) | 0 |
| | | Index-1 thru Index-6 | 0 |

*Zero in this column indicates an original page.

A/B blank

Operator's Manual

**DECONTAMINATING APPARATUS:
DIESEL ENGINE-DRIVEN (DED),
SKID-MOUNTED, 500-GALLON, M12A1
(NSN 4230-01-502-7224)
(EIC: 5FB)**

REPORTING ERRORS AND RECOMMENDING IMPROVEMENTS

You can help improve this manual. If you find any mistakes or if you know of a way to improve the procedures, please let us know. Mail your letter or DA Form 2028 (Recommended Changes to Publications and Blank Forms), located in the back of this manual directly to: Commander, US Army Tank-automotive and Armament Command, ATTN: AMSTA-LC-CECT, 15 Kansas St., Natick, MA 01760. You may also submit your recommended changes by E-mail directly to: <amssbriml@natick.army.mil>. A reply will be furnished directly to you. Instructions for sending electronic 2028 may be found at the back of this manual immediately preceding the hard copy 2028.

EQUIPMENT HOTLINE

Do you have a problem or question about the equipment covered in this publication and need to talk to someone? The Soldier and Biological Chemical Command (SBCCOM) has a hotline you can contact. The phone numbers are toll free from the USA and these lines are manned during our normal duty hours. If you call during our off duty hours you can leave a voice mail message and we will get back to you. Your E-mail or facsimile (FAX) message can be sent at any time and will be handled during the next business day.

The numbers are:

- Toll Free 1-800-831-4408
- DSN 584-1166
- Commercial. (410) 436-1166
- FAX (DSN) 584-3912
- FAX (Commercial)..... (410) 436-3912
- E-mail CEH@sbccom.apgea.army.mil

TABLE OF CONTENTS

Work Package Sequence

WARNING SUMMARY

HOW TO USE THIS MANUAL

CHAPTER 1. GENERAL INFORMATION, EQUIPMENT DESCRIPTION AND THEORY OF OPERATION

| | |
|--------------------------------------|---------|
| General Information | 0001 00 |
| Equipment Description and Data | 0002 00 |
| Theory of Operation | 0003 00 |

TABLE OF CONTENTS - Continued

Work Package Sequence

CHAPTER 2. OPERATOR INSTRUCTIONS

- Description and Use of Operator Controls and Indicators 0004 00
- Operation Under Usual Conditions: Assembly and Preparation for Use 0005 00
- Operation Under Usual Conditions: Starting and Stopping the Pump Unit 0006 00
- Operation Under Usual Conditions: Starting and Stopping the Water Heater and Spraying Water 0007 00
- Operation Under Usual Conditions: Spraying Decontaminant Solution..... 0008 00
- Operation Under Usual Conditions: Showering and Heating Water in Tank..... 0009 00
- Operation Under Usual Conditions: Decals and Instruction Plates 0010 00
- Operation Under Usual Conditions: Preparation for Movement 0011 00
- Operation Under Unusual Conditions 0012 00

CHAPTER 3. TROUBLESHOOTING PROCEDURES

- Troubleshooting Index..... 0013 00
- Troubleshooting Procedures 0014 00

CHAPTER 4. MAINTENANCE INSTRUCTIONS

- PMCS Introduction 0015 00
- General Cleaning Instructions and Before Operation PMCS..... 0016 00
- During Operation PMCS 0017 00
- After Operation PMCS 0018 00
- Quarterly and Annual PMCS..... 0019 00
- Lubrication Instructions 0020 00
- Personnel Sectional Shower Maintenance Instructions..... 0021 00
- Gun Assembly Maintenance Instructions..... 0022 00
- Pump Unit Subassembly Maintenance Instructions 0023 00
- Engine Air Filter Element Maintenance Instructions 0024 00
- Starter Maintenance Instructions 0025 00

CHAPTER 5. SUPPORTING INFORMATION

- References 0026 00
- Components of End Item (COEI) and Basic Issue Items (BII) Lists 0027 00
- Expendable and Durable Items..... 0028 00

ALPHABETICAL INDEX

HOW TO USE THIS MANUAL

This manual is used by the operator to operate and maintain the decontaminating apparatus. You, the user, must familiarize yourself with the information contained in this manual before attempting to operate or maintain this equipment.

This manual is to be used with M12A1 units that have been modified with a diesel engine. Modified units are identified by a plate mounted on the upper left corner of the pump unit control panel.

If the equipment fails to function properly after following the approved procedures given in the manual, notify your immediate supervisor. Do not attempt to apply unauthorized repairs or parts; extensive damage may result.

The manual is divided into five chapters as follows:

CHAPTER 1. GENERAL INFORMATION, EQUIPMENT DESCRIPTION AND THEORY OF OPERATION provides general information about the system; identifies the major components of the system; and describes how the components work.

CHAPTER 2. OPERATOR INSTRUCTIONS explains how to set up, operate, and stow the system.

CHAPTER 3. TROUBLESHOOTING PROCEDURES provides corrective actions for equipment malfunctions which may occur during operation of the M12A1 DED Decontaminating Apparatus.

CHAPTER 4. MAINTENANCE INSTRUCTIONS explains what the operator can do to keep the M12A1 DED Decontaminating Apparatus in good working order. It contains the Preventive Maintenance Checks and Services instructions.

CHAPTER 5. SUPPORTING INFORMATION provides additional information needed to operate and maintain the M12A1 DED Decontaminating Apparatus. It contains Work Packages which list publication references, Components of End Item and Basic Issue Items Lists, and Expendable and Durable Items.

This manual has a Table of Contents, beginning on page i, and an alphabetical subject index in the back of the manual to help you find the information you need.

WORK PACKAGES

This manual has been organized using the Work Packages concept. Each chapter contains a series of Work Packages rather than section and paragraphs. Each Work Package is designed to stand alone as a complete module of information; if you keep your section of this manual in a loose-leaf binder, you will be able to remove just the pages you need to do a specific task. Here are some of the features of Work Packages that you should be aware of in order to help you understand the organization of this manual:

- Each Work Package is numbered sequentially throughout the manual using a six-digit number. Go to the table of contents and you will see that the very first work package is numbered "0001 00". The second work package is numbered 0002 00.
- The last two digits (00) allow insertion of new work packages if needed. For example, if it is necessary to add an instruction or maintenance task between Work Package 0001 00 and Work Package 0002 00 in this manual, the new Work Package would be numbered 0001 01.
- The Work Package number is located at the top of each page on the right side. It also is located at the bottom of each Work Package page as part of the Work Package page number. For example, the page number for the first page of the second Work Package of this manual is 0002 00-1.

HOW TO USE THIS MANUAL - Continued

WORK PACKAGES - Continued

- Each Work Package starts on a right hand page. This was done so you can remove a single Work Package from your paper manual if needed for a particular task. Each Work Package containing step-by-step procedures will end with "END OF WORK PACKAGE." Think of each work package as a small stand-alone manual of its own.

WARNINGS, CAUTIONS, AND NOTES

Warnings are provided where injury may occur to personnel when using or maintaining the M12A1 DED Decontaminating Apparatus. Warnings are preceded by the word WARNING as shown below. These warnings are located immediately before any operating or maintenance task that applies and they are also summarized at the front of this manual.

WARNING

Fire and explosion danger exist when solvent cleaning compound is used. Make sure that equipment is dry before operations begin.

Cautions are provided where equipment may be damaged but no personal injury should result. Cautions are preceded by the word CAUTION as shown below:

CAUTION

Do not operate pump dry or when discharge pressure is below 60 psi. If more time is needed to correct fault, shut down.

Notes provide helpful information to operate or maintain the equipment but no equipment damage or personal injury is involved as shown below:

NOTE

Operating time for M12A1 DED is approximately 5 hours with a full tank.

CHAPTER 1

**GENERAL INFORMATION, EQUIPMENT DESCRIPTION
AND THEORY OF OPERATION
FOR
M12A1 DIESEL ENGINE-DRIVEN DECONTAMINATING APPARATUS**

**OPERATOR
M12A1 DIESEL ENGINE DRIVEN DECONTAMINATION APPARATUS
NSN 4230-01-502-7224
GENERAL INFORMATION**

SCOPE**Type of Manual**

Operator's Manual, containing instructions for operation and operator (crew) maintenance. This manual is to be used with M12A1 units modified with a diesel engine. Modified units are identified by a plate mounted on the upper left corner of the pump unit control panel.

Model Number and Equipment Name

The M12A1 Decontaminating Apparatus, Diesel Engine Driven, Skid Mounted: 500-Gallon consists of:

- Decontaminating Apparatus (Skid-Mounted) Pumping Unit
- Decontaminating Apparatus Skid-Mounted Tank Unit
- Personnel Sectional Shower Assembly
- Liquid Fuel Water Heater

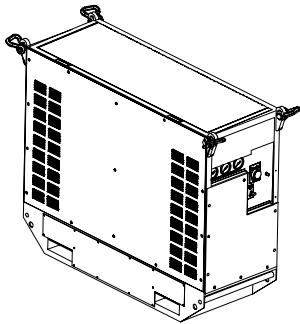

Liquid Fuel Water Heater

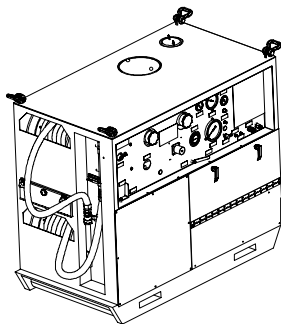

Pump Unit Assembly

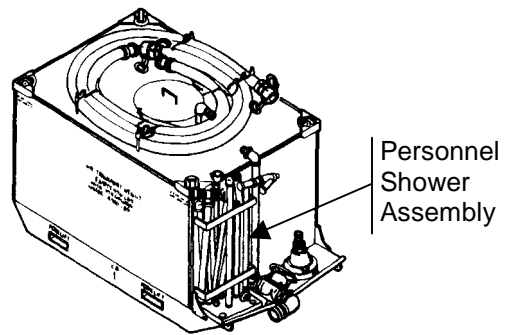

Tank Unit Assembly

Purpose of Equipment

Provides the capability of spraying decontaminating materials, firefighting, deicing, cleaning vehicles, pumping various fluids, and showering personnel.

MAINTENANCE FORMS AND RECORDS

Department of the Army forms and procedures used for equipment maintenance will be those prescribed by DA PAM 738-750, The Army Maintenance Management System (TAMMS).

REPORTING EQUIPMENT IMPROVEMENT RECOMMENDATIONS (EIR)

If your decontaminating apparatus needs improvement, let us know. Send us an EIR. You, the user, are the only one who can tell us what you don't like about your equipment. Let us know why you don't like the design. Tell us why a procedure is hard to perform. Put it on an SF 368 (Product Quality Deficiency Report). Mail it to us at: Commander, U.S. Army Tank-automotive and Armament Command, ATTN: AMSTA-LC-R, 15 Kansas Street, Natick, MA 01760-5052. We'll send you a reply.

CORROSION PREVENTION AND CONTROL (CPC)

Corrosion Prevention and Control (CPC) of Army materiel is a continuing concern. It is important that any corrosion problems with this item be reported so that the problem can be corrected and improvements can be made to prevent the problem in future items.

While corrosion is typically associated with rusting of metals, it can also include deterioration of other materials, such as rubber and plastic. Unusual cracking, softening, swelling, or breaking of these materials may be a corrosion problem.

If a corrosion problem is identified, it can be reported using SF 368, Product Quality Deficiency Report. Use of key words such as "corrosion," "rust," "deterioration," or "cracking" will ensure that the information is identified as a CPC problem.

The form should be submitted to the address specified in DA PAM 738-750, Functional Users Manual for the Army Maintenance Management System (TAMMS).

DESTRUCTION OF ARMY MATERIEL TO PREVENT ENEMY USE

For procedures to destroy this equipment to prevent its use by the enemy, refer to TM 43-0002-31, Destruction of Chemical Weapons and Defense Equipment to Prevent Enemy Use.

PREPARATION FOR STORAGE OR SHIPMENT

Refer to Work Package 0005 00.

NOMENCLATURE CROSS-REFERENCE LIST

Common Name

Blender hose assembly
Decontaminating apparatus

Hopper assembly
Water heater
Personnel shower assembly
Pump unit

Tank drain valve
Tank unit

Official Name

Hose assembly
Decontaminating Apparatus, Diesel Engine-Driven, Skid-Mounted: 500-Gallon, M12A1
Liquid storage tank
Heater, Water, Liquid Fuel
Shower Assembly, Personnel Sectional
Pumping Unit, Multipurpose Nonintegral
Decontaminating Apparatus (Skid-Mounted)
Regulating valve
Tank Unit, Decontaminating Apparatus Skid-Mounted

LIST OF ABBREVIATIONS/ACRONYMS

Abbreviation

C
DED
DFA
F
GAA
gal.
gpm
in.
kg
lb
lpm

Definition

Celsius
Diesel Engine Driven
Diesel Fuel, Arctic
Fahrenheit
Grease, automotive and artillery
gallon(s)
gallons per minute
inch/inches
kilogram(s)
pound(s)
liters per minute

LIST OF ABBREVIATIONS/ACRONYMS - Continued

| <u>Abbreviation</u> | <u>Definition</u> |
|----------------------------|--|
| min | minute(s) |
| mm | millimeter(s) |
| PMCS | Preventive Maintenance Checks and Services |
| psi | pounds per square inch |
| sq ft | square feet |
| sq m | square meters |
| sq yd | square yard(s) |
| STB | Super Tropical Bleach |
| Vdc | Volts direct current |
| WP | Work Package |

QUALITY OF MATERIAL

Material used for replacement, repair, or modification must meet the requirements of this manual. If quality of material requirements are not stated in this manual, the material must meet the requirements of the drawings, standards, specifications, or approved engineering change proposals applicable to the subject equipment.

SAFETY, CARE AND HANDLING

Be sure to follow the Warnings and Cautions in the Warning Summary located in the front of this manual and the Warnings and Cautions in the Operating and Maintenance procedures.

END OF WORK PACKAGE

**OPERATOR
M12A1 DIESEL ENGINE DRIVEN DECONTAMINATION APPARATUS
NSN 4230-01-502-7224
EQUIPMENT DESCRIPTION AND DATA**

EQUIPMENT CHARACTERISTICS, CAPABILITIES, AND FEATURES

The decontaminating apparatus is intended for field use. The pump, tank, personnel shower assembly, and water heater units are designed to be stationary or mobile and are used for spraying decontaminating materials, firefighting with water or foam, deicing, cleaning vehicles, pumping various fluids, and showering personnel. It is not authorized for use with defoliant, herbicides, or insecticides.

LOCATION AND DESCRIPTION OF MAJOR COMPONENTS

Pump Unit

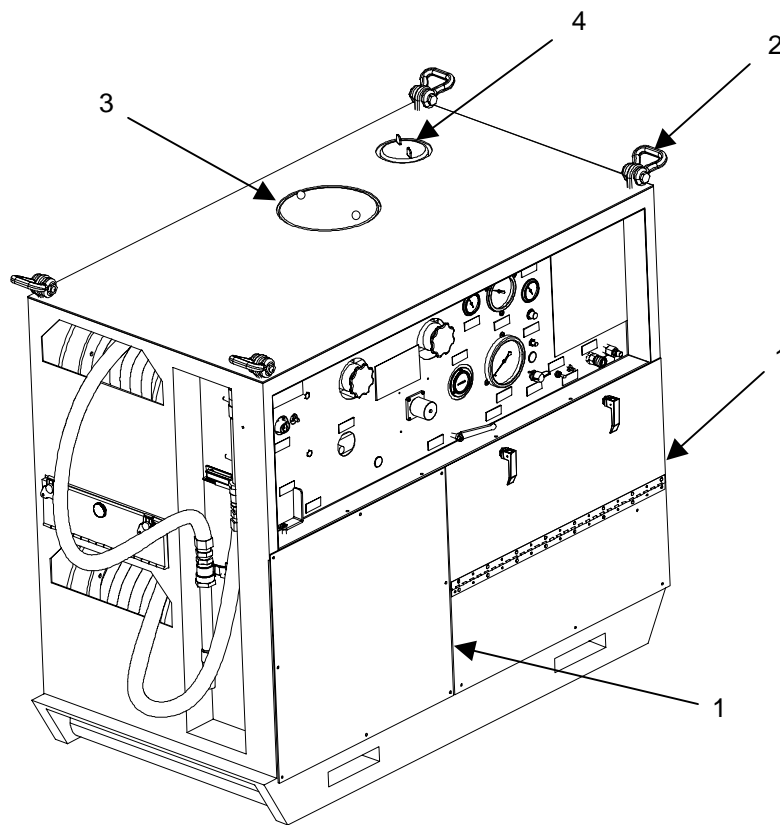

COVER PANELS (1). Fitted sheet-metal, quick-release hinged panels protect the pump unit from the elements. When opened, the panels give access to components and ventilate the diesel engine.

LIFTING EYE ASSEMBLY (2). Four lifting eyes, on top of the pump unit are used to pick up the pump unit assembly.

PRIME DETERGENT TANK AND LID (3). The 10-gallon prime-detergent tank is used to prime the pump, to store detergent for cleaning or to store foam for firefighting. The lid prevents foreign objects from entering prime detergent tank.

FUEL TANK AND FUEL TANK CAP (4). The 20-gallon fuel tank stores diesel fuel for the engine and also for the heater on the diesel engine configuration. The fuel tank cap has an internal selector valve. When open, the valve vents the fuel tank. The cap prevents dirt and moisture from entering the fuel tank.

CONTROL PANEL (5). Contains all the gages and valves for operating the engine and for controlling pump delivery.

DIESEL ENGINE (6). The 19 hp engine supplies power through a pulley and four drive belts to drive the pump and through a pulley and one drive belt to drive the alternator.

FRAME ASSEMBLY (7). A welded steel frame that supports components of the pump unit.

PUMP (8). Pumps fluids from water source to tank unit and then, if needed, to water heater. Also mixes detergent or foam from the prime detergent tank with water.

24-VOLT BATTERY (9). Provides electrical energy to start the engine.

SKID ASSEMBLY (10). Provides a base for the pump unit assembly, and provides a means to forklift the entire unit.

GUN ASSEMBLIES (11). Consist of either a water, slurry, or foam nozzle on an extension pipe with a ball valve. Controls water flow.

DISCHARGE HOSES (12). Stored on the two hose reels. The hoses discharge fluid for decontamination, firefighting, or for showers.

HEATER RECEPTACLE AND SWITCH (13). The water heater's main electrical power cable connects to the socket receptacle on the pump unit control panel.

ALTERNATOR (14). Supplies power to the water heater through the pump unit control panel. Recharges the 24-volt battery while the equipment is operating.

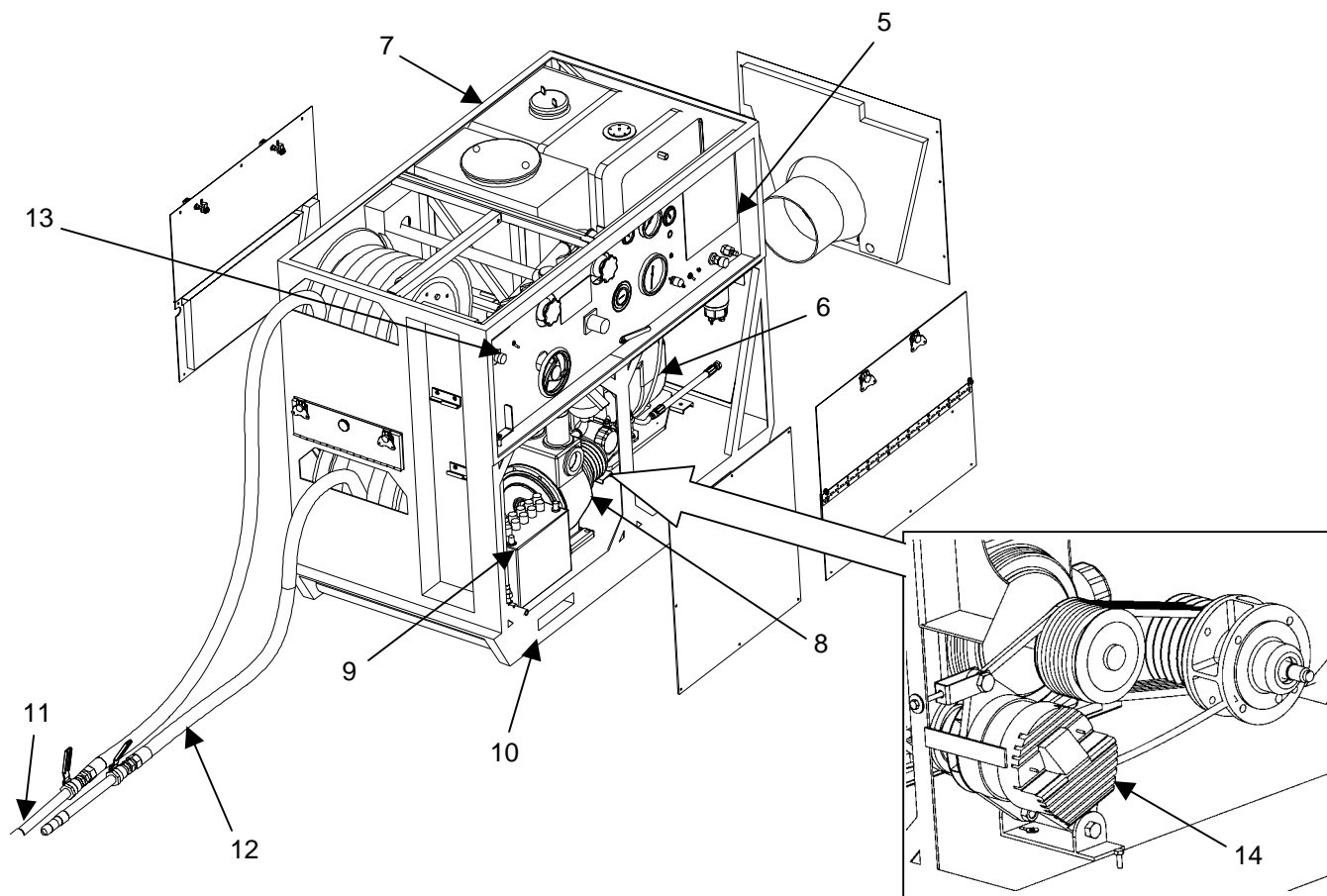

Tank Unit and Personnel Shower Assembly

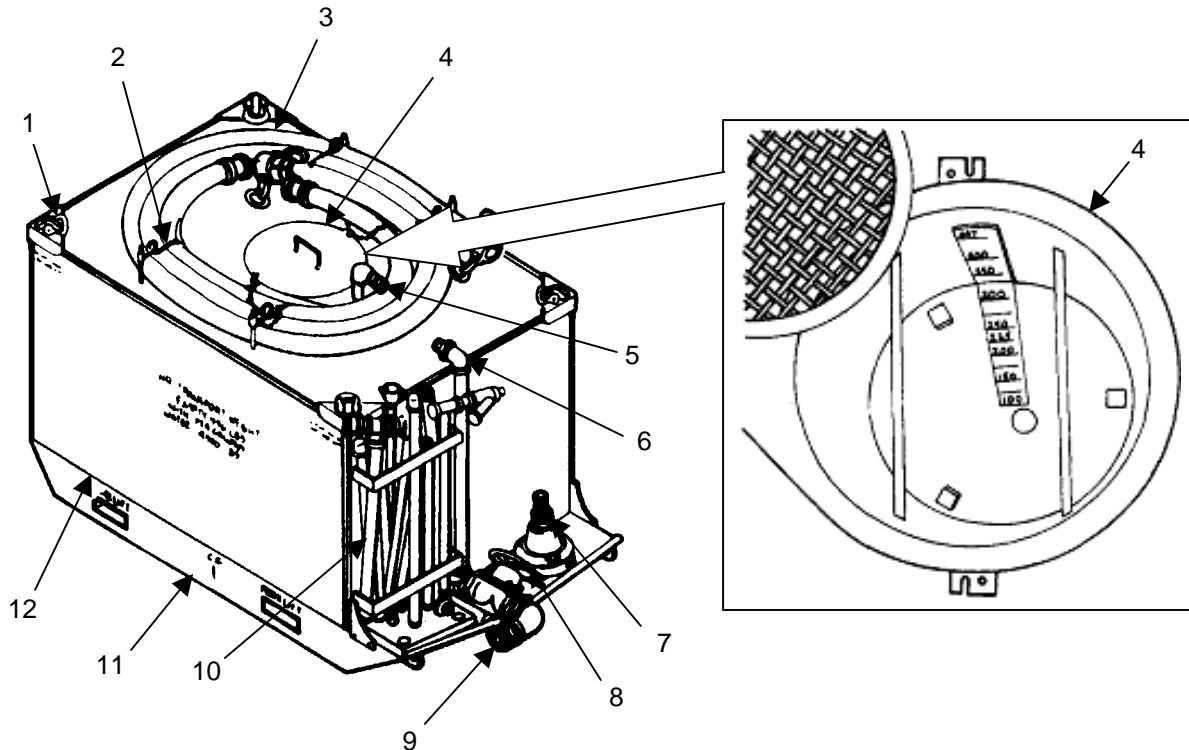

LIFTING EYE ASSEMBLY (1). Four lifting eyes, on the top of the tank unit, are used to pick up the tank unit.

BRACKET CLAMP (2). Secures the suction hose on top of the tank unit when not in use.

SUCTION HOSE (3). Carries water from the tank unit through the tank drain valve or from a natural source to the pump unit.

HOPPER-BLENDER ASSEMBLY AND COVER (4). The hopper-blender assembly along with a fluid agitation system in the tank blends decontaminating agent with water. The cover prevents foreign objects from entering the hopper-blender assembly.

BLENDER PIPE (5). Uses water from the pump unit to blend agents in the hopper-blender assembly.

AGITATOR PIPING (6). Uses water from the pump unit to agitate slurry in the tank unit assembly and is the passage for heated water from the heater unit.

FOOT VALVE ASSEMBLY (7). Prevents objects from clogging the suction hose when water is being pumped from a natural source. Clogs could damage the pump.

TANK DRAIN VALVE (8). Drains the tank unit.

HOSE ADAPTER (9). Provides for quick disconnect of the suction hose.

PERSONNEL SHOWER ASSEMBLY (10). Consists of pipes, couplings, and adapters. When connected, they form a field shower to mass shower personnel in the field. When dismantled, it is stowed on the tank unit.

TANK UNIT SKID (11). Provides a base for the tank unit and provides a means to forklift tank unit.

TANK ASSEMBLY (12). Has a volume of 500 gallons and a maximum working capacity of approximately 447 gallons of water. Working capacity for the tank with slurry mix is 317 gallons.

Water Heater

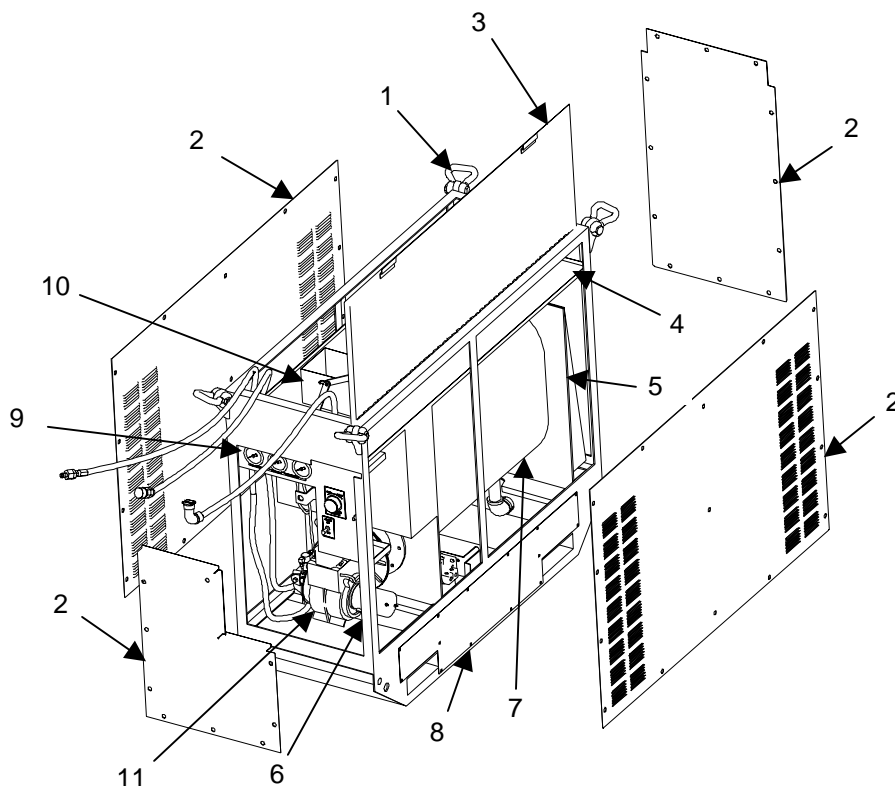

LIFTING EYE ASSEMBLY (1). Four lifting eye assemblies are used to pick up the water heater.

COVER PANELS (2). Fitted sheet-metal, quick-release removable panels protect the water heater from the elements. When removed, the panels give access to components.

COVER (3). When heater is not used, the cover protects the water hoses, fuel hose assembly, power cable and keeps rain out of the heater exhaust stack. When the heater is used, the cover must be open so exhaust gases can be vented through the top of the heater. A canvas tool carrier is also attached inside of cover.

HOSE AND CABLE STORAGE COMPARTMENTS (4). Stores power cable assembly, fuel hose and filler opening assembly, and water hose assembly.

REFRACTORY BOX (5). Evenly distributes heat from the burner through the boiler into the heat exchange tubing, where most of the heat exchange takes place.

FRAME (6). A welded steel frame that serves as a mount for components of the water heater.

BOILER (7). A holding tank for heating water.

SKID ASSEMBLY (8). Provides a base for the water heater and a means to forklift the entire unit.

CONTROL BOX (9). Contains THERMOSTAT, HEATER ON/OFF switch, MAIN CIRCUIT BREAKER, and WATER PRESSURE, FUEL PRESSURE and WATER TEMPERATURE gages.

EXHAUST STACK (10). Exhausts heat and fumes from the combustor or burner assembly.

BURNER ASSEMBLY (11). The burner assembly is an all-inclusive motor, fan, fuel pump, igniter, nozzle, and electrodes contained on a housing, which atomizes and ignites the fuel mixture and then forces the burning fuel-air mixture through the boiler.

EQUIPMENT DATA

Weights and Dimensions

| Components | Length in./mm | Width in./mm | Height in./mm | Weight (approx) lb/kg | Cubic Feet |
|-----------------------|------------------|-----------------|------------------|--------------------------|------------|
| Pump unit (crated) | 61/1550 | 39/990 | 58/1430 | 1,660/755 | 81 |
| (uncrated) | 56/1430 | 32/813 | 51/1300 | 1,010/459 | 52 |
| Tank unit (crated) | 88/2240 | 53/1320 | 67/1 700 | 1,690/767 | 153 |
| (uncrated) | 82/2080 | 45/1140 | 51/1300 | 996/452 | 102 |
| Water heater (crated) | 57/1450 | 24/610 | 47/1190 | 731/332 | 37 |
| (uncrated) | 53/1350 | 21/530 | 43/1100 | 575/261 | 22 |

Tabulated Data

TANK UNIT

| | |
|---|--------------------------|
| Working capacity, water only | 447 gal. (1692 liters) |
| STB decontaminating agent(slurry)..... | 317 gal. (1200 liters) |
| Water (per filling for slurry)..... | 225 gal. (851.63 liters) |
| STB decontaminating agent per filling (dry) | 1,300 lb (590 kg) |
| M2 antiset compound per filling (dry)..... | 12-1/2 lb (5.68 kg) |
| Weight of 317 gallon slurry mixture..... | 3.170 lb (1,437.89 kg) |

NOTE

When being airlifted by UH-1H aircraft, the tank unit (996 lb empty) plus the water must weigh less than 4,000 pounds (1,814.37 kg). Fill the tank unit with no more than 374 gallons (1,415.59 liters) of water for airlift operations. When being airlifted by UH-60A aircraft, the tank unit weight is limited to 7,000 lb. However, when the tank unit is airlifted by CH-47 aircraft, the tank weight is unlimited.

SPACE REQUIREMENTS

| | |
|-------------------|---------------------|
| Pump Unit..... | 15 sq ft(1.4 sq m) |
| Tank Unit..... | 25 sq ft (2.3 sq m) |
| Water Heater..... | 20 sq ft (1.8 sq m) |

CENTRIFUGAL PUMP

| | |
|----------------|--------------------------------------|
| Capacity | 50 gpm (189.27 lpm) |
| Pressure..... | 60-120 psi (42, 186-84, 372 kg/sq m) |

TANK CAPACITIES (PUMP UNIT)

| | |
|---------------------------|-----------------------|
| Prime-Detergent tank..... | 10 gal (37.85 liters) |
| Fuel tank | 20 gal (75.70 liters) |

EQUIPMENT DATA - Continued**Tabulated Data - Continued**

APPROXIMATE TIME REQUIRED FOR LOADING AND MIXING

Loading tank with water (after priming) 50 gpm (189.25 lpm)
Loading tank with antiset 1 min
Mixing antiset with water 2 min
Loading tank with antifoam 1 min
Mixing antifoam with water 2 min
Loading tank with STB decontaminating agent 35 min
Agitation continuous

ENGINE, DIESEL, Model MD191, Ruggerini

Weight 152 lb/69 kg

WATER HEATER

Electrical input 24 Vdc
Maximum operating water pressure 200 psi (126558 kg/sq m)
Maximum operating water temp 200°F (93.3°C)

COMPONENT AND NATIONAL STOCK NUMBER

Pump unit NSN 4230-01-502-7225
Tank unit NSN 4230-00-735-9931
Water heater NSN 4230-01-502-6866

END OF WORK PACKAGE

**OPERATOR
M12A1 DIESEL ENGINE DRIVEN DECONTAMINATION APPARATUS
NSN 4230-01-502-7224
THEORY OF OPERATION**

The pump unit is powered by a diesel engine that operates on diesel or JP-8 fuel. The fuel system is a circulatory system that pumps fuel to the engine and burner and returns unused fuel to the fuel tank through a return line. Furthermore, the pump unit fuel tank not only supplies fuel to the engine but also supplies fuel to the burner unit through two quick disconnects on the control panel. The 50-amp alternator supplies power to both the burner unit and the pump unit. The control panel includes a 40-amp and a 15-amp circuit breaker, voltmeter, hourmeter, pre-heater switch, and a slave receptacle. The front and rear engine panels have latches that allow access to the engine. In addition, the rear panel opens to allow venting of exhaust during operation. The side engine panel has been vented and has an air intake cone that allows the system to operate without physically removing the engine panels.

The water heater unit includes a self-contained burner. The burner assembly consolidates the fuel pump and voltage transformer (igniter) with the motor-blower and electrode/nozzle. Two fuel lines are routed through the top of the burner unit and are attached to the fuel filter and to the burner pump fuel return. These fuel lines, one a feed line and the other a return line, connect to the pump unit fuel tank via the quick disconnects attached to the pump front panel. The control panel includes a 15-amp circuit breaker, an ON/OFF switch, and a thermostat for water temperature.

END OF WORK PACKAGE

CHAPTER 2

OPERATOR INSTRUCTIONS
FOR
M12A1 DIESEL ENGINE-DRIVEN DECONTAMINATING APPARATUS

**OPERATOR
M12A1 DIESEL ENGINE DRIVEN DECONTAMINATION APPARATUS
NSN 4230-01-502-7224
DESCRIPTION AND USE OF OPERATOR CONTROLS AND INDICATORS**

GENERAL

Table 1 describes the controls and indicators used to operate the decontaminating apparatus. The controls and indicators are located on the pump unit control panel, the water heater control panel, and the tank unit.

Table 1. OPERATOR'S CONTROLS AND INDICATORS

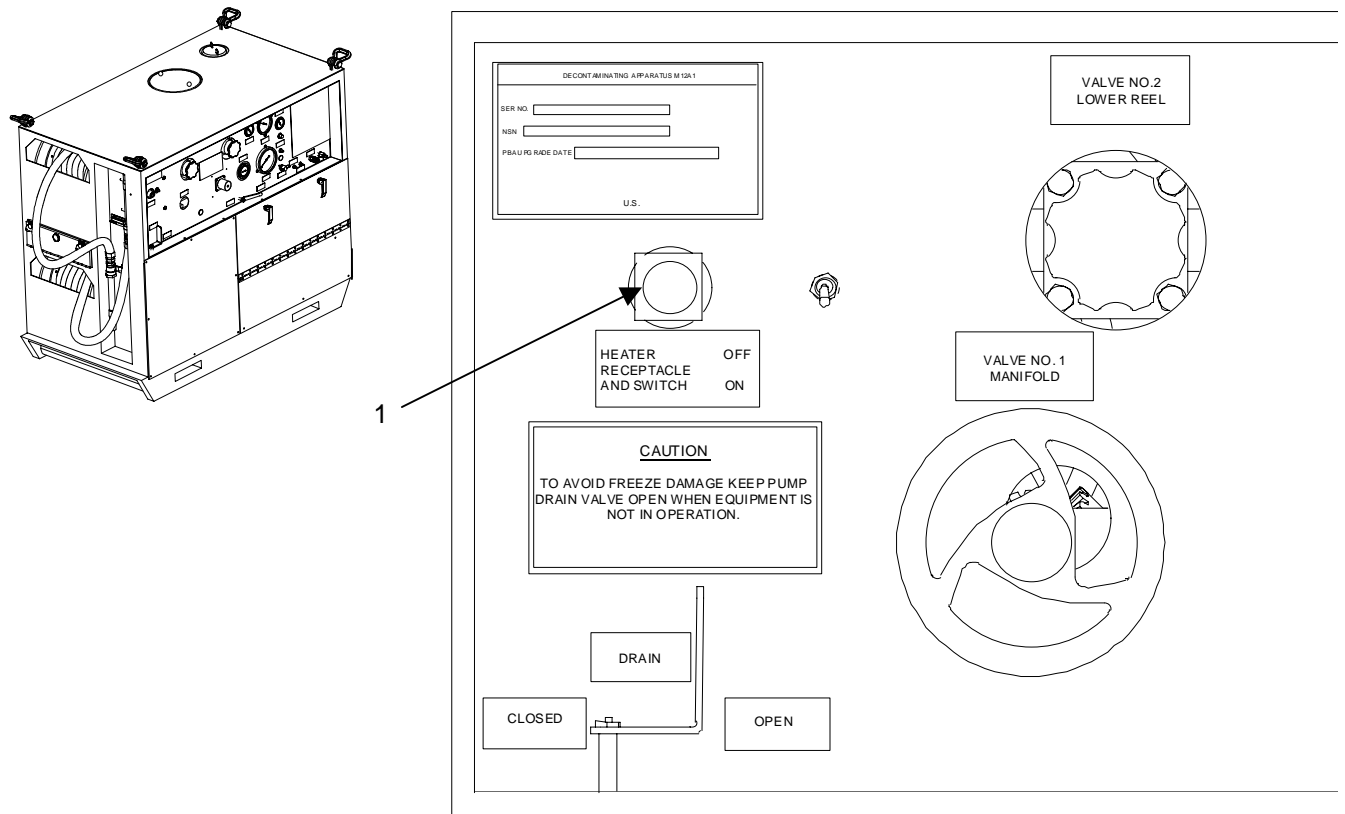

| Key | Control or Indicator | Function |
|-----|---|--|
| 1 | HEATER RECEPTACLE AND SWITCH on pump unit | <p style="text-align: center;">Pump Unit Control Panel</p> <p>Supplies power to operate the water heater.</p>  |

Table 1. OPERATOR'S CONTROLS AND INDICATORS - Continued



| Key | Control or Indicator | Function |
|-----|------------------------|--|
| 2 | VALVE NO. 2 LOWER REEL | <p>Pump Unit Control Panel (Cont)</p> <p>Diaphragm valve. Controls the flow of liquids from the upper manifold to lower hose reel discharge hose.</p>  |

Table 1. OPERATOR'S CONTROLS AND INDICATORS – Continued

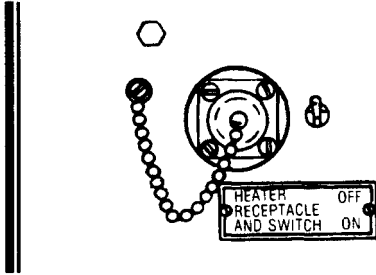
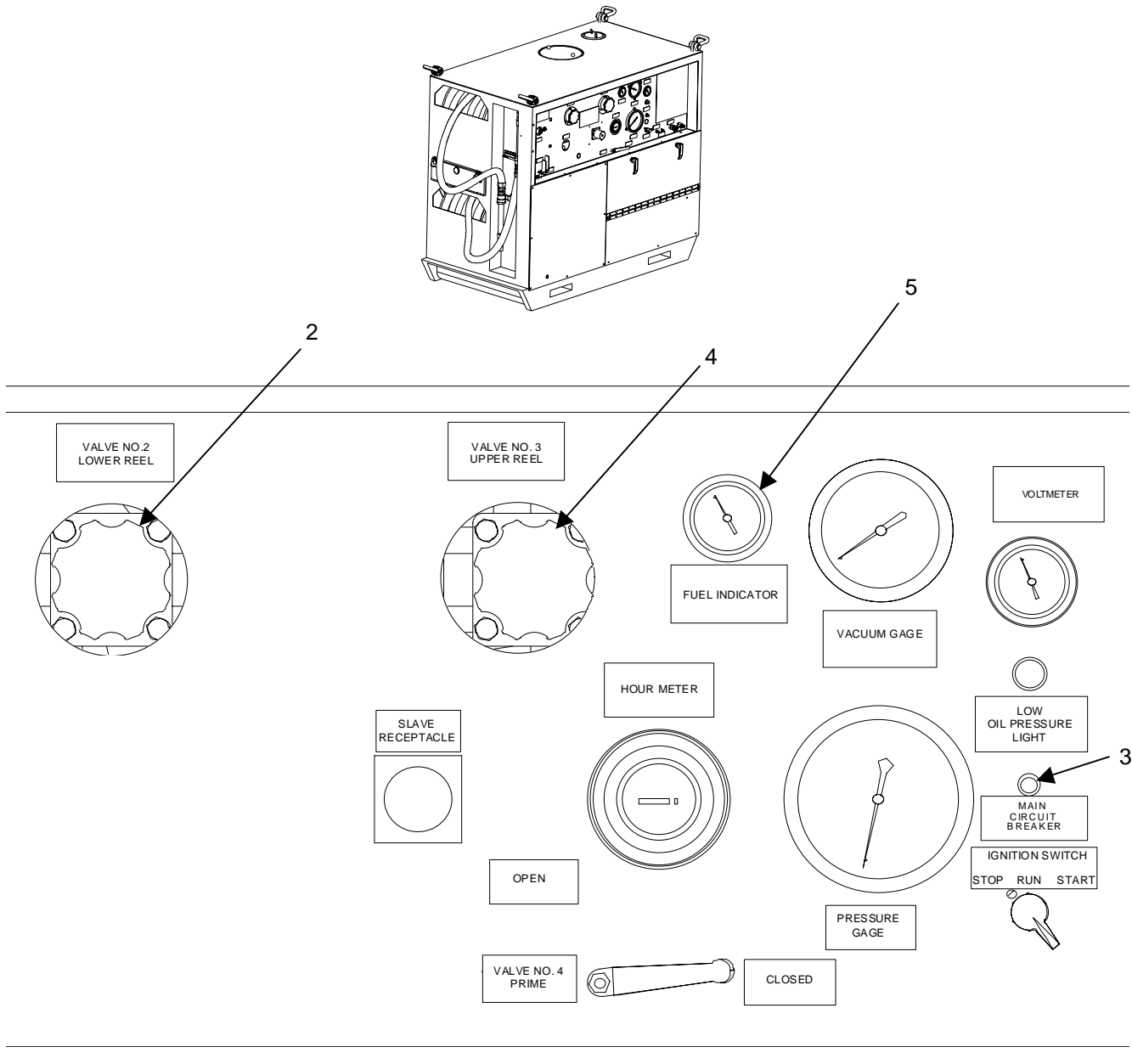
| Key | Control or Indicator | Function |
|-----|---------------------------|---|
| 3 | MAIN CIRCUIT BREAKER | <p>Pump Unit Control Panel (Cont)</p> <p>Starting circuit overload protection. To reset, push in. Disables battery power to M12A1 circuits.</p>  |
| 4 | VALVE No. 3 UPPER REEL | <p>Diaphragm valve. Controls the flow of liquid from the upper manifold to the upper hose reel discharge hose.</p>  |
| 5 | FUEL INDICATOR Gage | <p>Continuously registers the amount of diesel fuel in the fuel tank when the START switch is in the RUN position.</p>  |

Table 1. OPERATOR'S CONTROLS AND INDICATORS - Continued

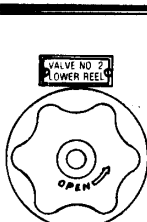

| Key | Control or Indicator | Function |
|-----|----------------------|---|
| 6 | VACUUM GAGE | <p>Pump Unit Control Panel (Cont)</p> <p>Indicates the intake vacuum of the pump in inches of mercury (0-30).</p> |

Table 1. OPERATOR'S CONTROLS AND INDICATORS - Continued

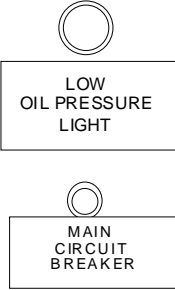
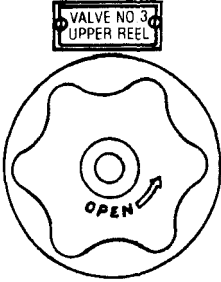
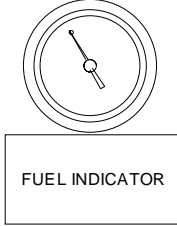
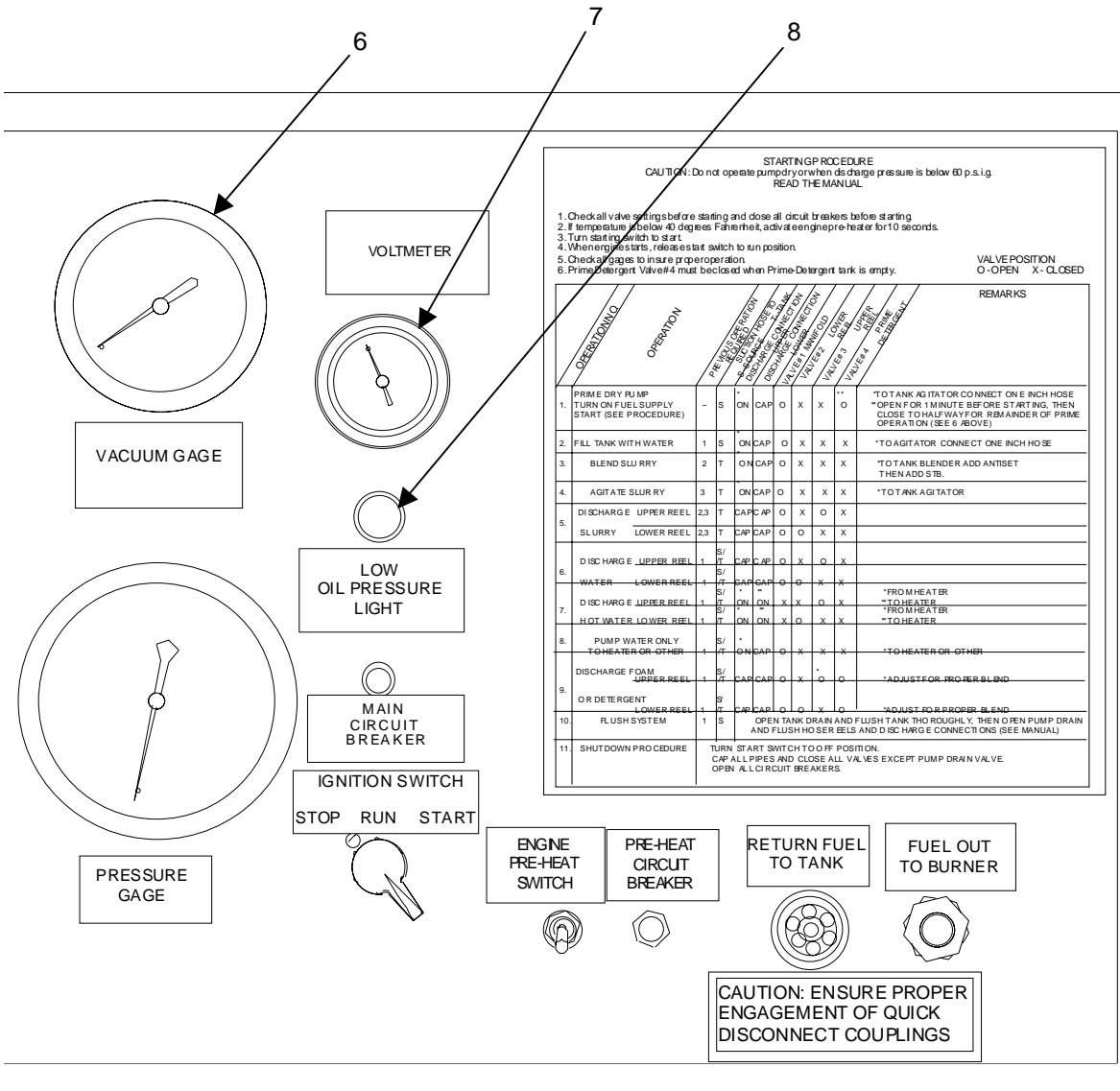
| Key | Control or Indicator | Function |
|-----|-------------------------------|---|
| 7 | VOLTMETER | <p>Pump Unit Control Panel (Cont)</p> <p>Measures the battery voltage before starting engine and the voltage output of the alternator after the engine is started.</p>  |
| 8 | Engine LOW OIL PRESSURE LIGHT | <p>CAUTION</p> <p>Do not operate if light remains illuminated after engine is started.</p> <p>Illuminates when engine oil pressure is low. Do not operate if oil light is illuminated.</p>   |
| 9 | Fuel shutoff valve | <p>Controls the flow of fuel from the fuel tank to the engine.</p>  |

Table 1. OPERATOR'S CONTROLS AND INDICATORS - Continued



| Key | Control or Indicator | Function |
|-----|-------------------------|---|
| 10 | IGNITION (Start) SWITCH | Pump Unit Control Panel (Cont) |
| | | Three position (STOP, RUN, and START) rotary switch. Controls starter and ignition power to the engine. <div data-bbox="857 1486 1247 1806" style="text-align: center; margin-top: 20px;"> <p>IGNITION SWITCH STOP RUN START</p> </div> |

Table 1. OPERATOR'S CONTROLS AND INDICATORS - Continued

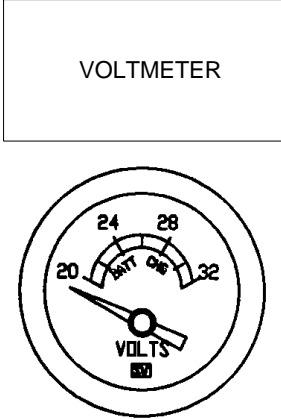
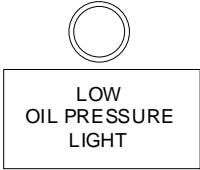
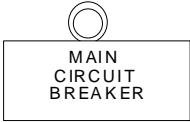
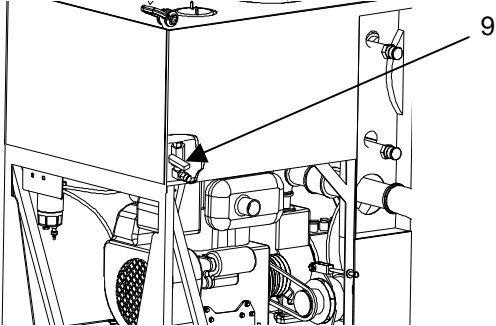
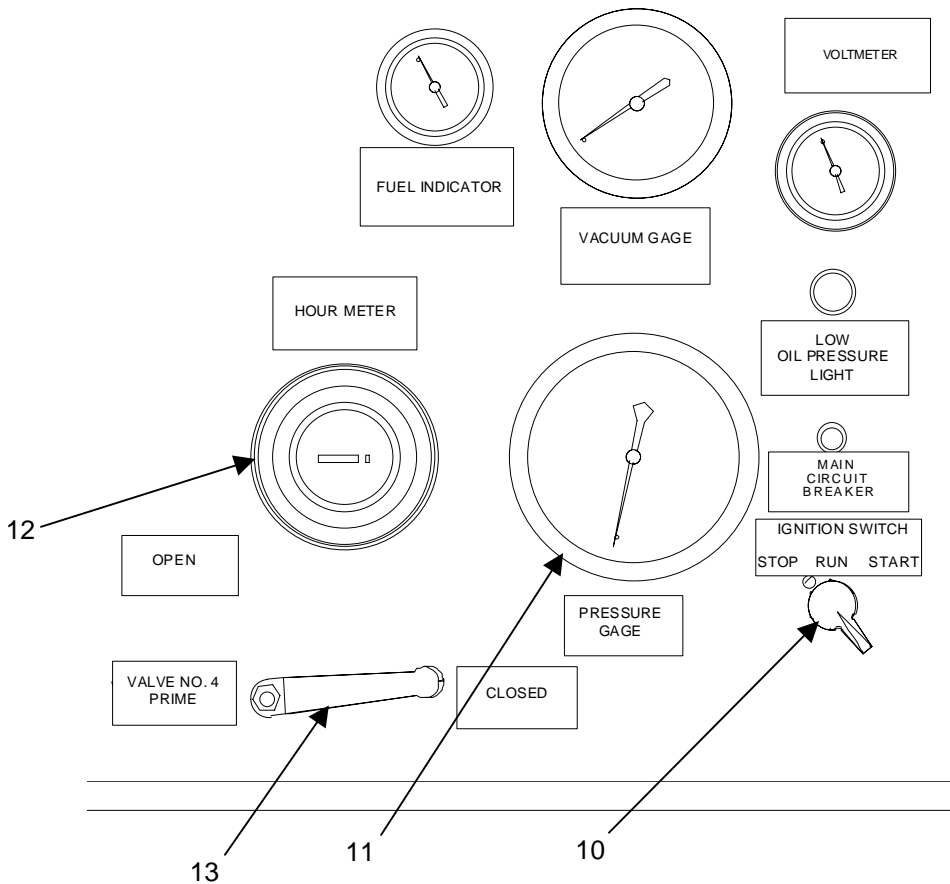
| Key | Control or Indicator | Function |
|-----|----------------------|---|
| 11 | Water PRESSURE GAGE | <p style="text-align: center;">Pump Unit Control Panel (Cont)</p> <p>Indicates the pump discharge pressure in psi (0-300).</p> <div style="text-align: center;">  </div> |
| 12 | HOURMETER | <p>The HOURMETER indicates total running time of the engine.</p> <div style="text-align: center;">  </div> |
| 13 | VALVE NO. 4 PRIME | <p>Controls flow of liquid from the prime-detergent tank through the eductor to the pump.</p> <div style="text-align: center;">  </div> |

Table 1. OPERATOR'S CONTROLS AND INDICATORS - Continued



| Key | Control or Indicator | Function |
|--------------------------------|--------------------------|---|
| Pump Unit Control Panel (Cont) | | |
| 14 | VALVE NO. 1 MANIFOLD | Offset diaphragm valve selects the routing of liquid discharged by the pump.  |
| 15 | Pump DRAIN valve | Ball valve controls liquid draining from the pump. |
| 16 | Pump DRAIN valve CAUTION | Alerts user to keep the pump DRAIN valve OPEN when the equipment is not in operation to prevent water from freezing in the pump. <p style="text-align: center;">CAUTION TO AVOID FREEZE DAMAGE KEEP PUMP DRAIN VALVE OPEN WHEN EQUIPMENT IS NOT IN OPERATION</p> |
| 17 | SLAVE RECEPTACLE | External power outlet/inlet. |

Table 1. OPERATOR'S CONTROLS AND INDICATORS - Continued

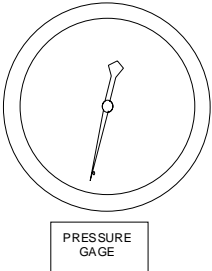
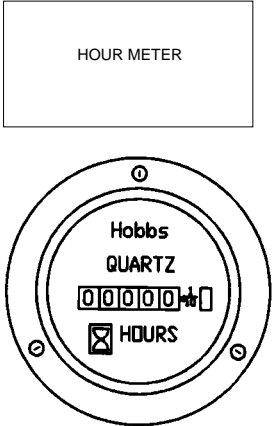
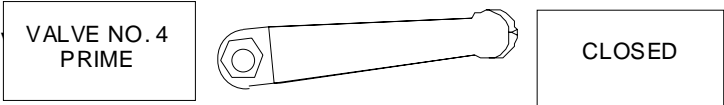
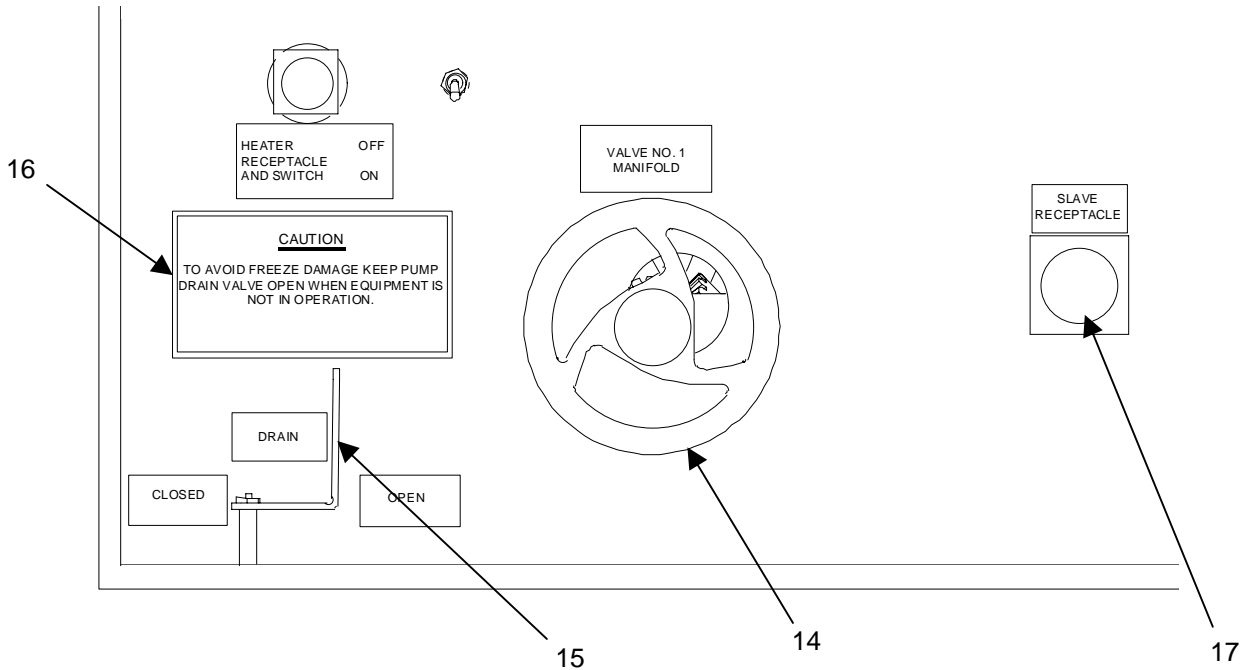

| Key | Control or Indicator | Function |
|--------------------------------|---------------------------------|--|
| Pump Unit Control Panel (Cont) | | |
| 18 | ENGINE PRE-HEAT SWITCH | Momentary switch that activates glow plug in diesel engine. If temperature is below 40 F (4.44° C), press switch up to activate glow plug. |
| 19 | Fuel hose connections | Connections for fuel hoses to and from water heater. |
| 20 | 40 Amp PRE-HEAT CIRCUIT BREAKER | Controls power to glow plugs. Tripped breaker indicates short circuit in system. |

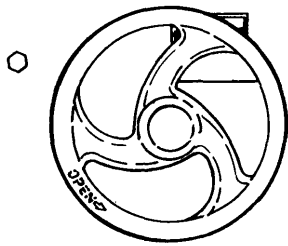
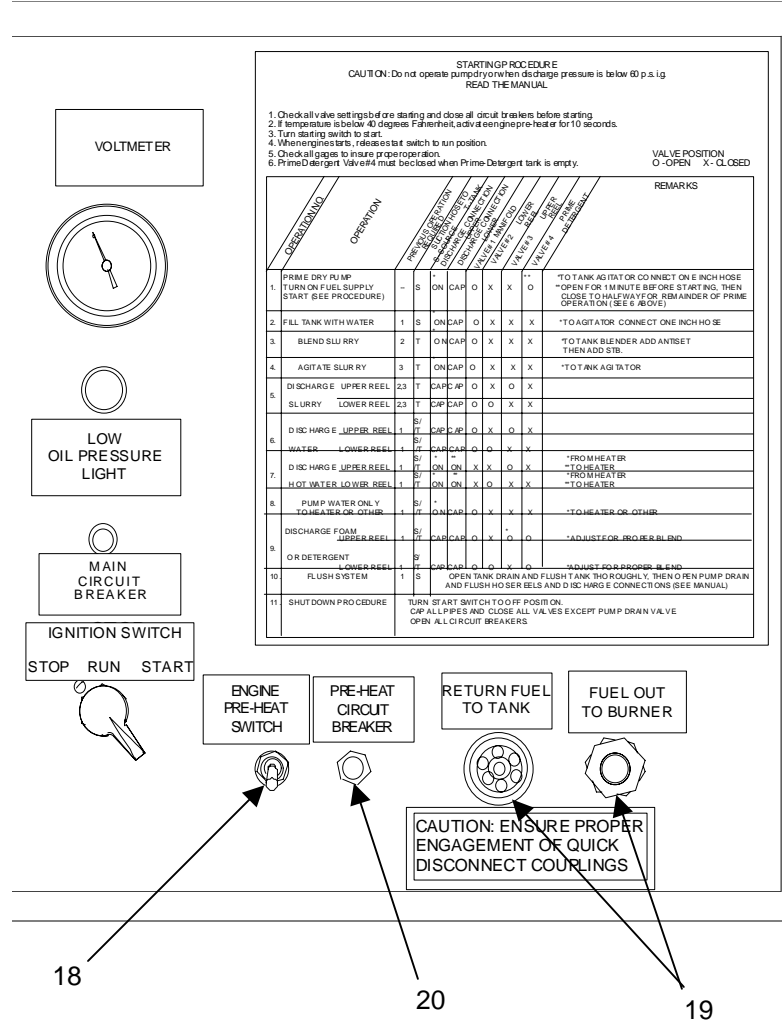
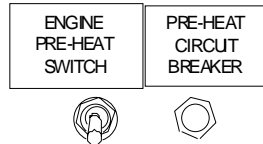
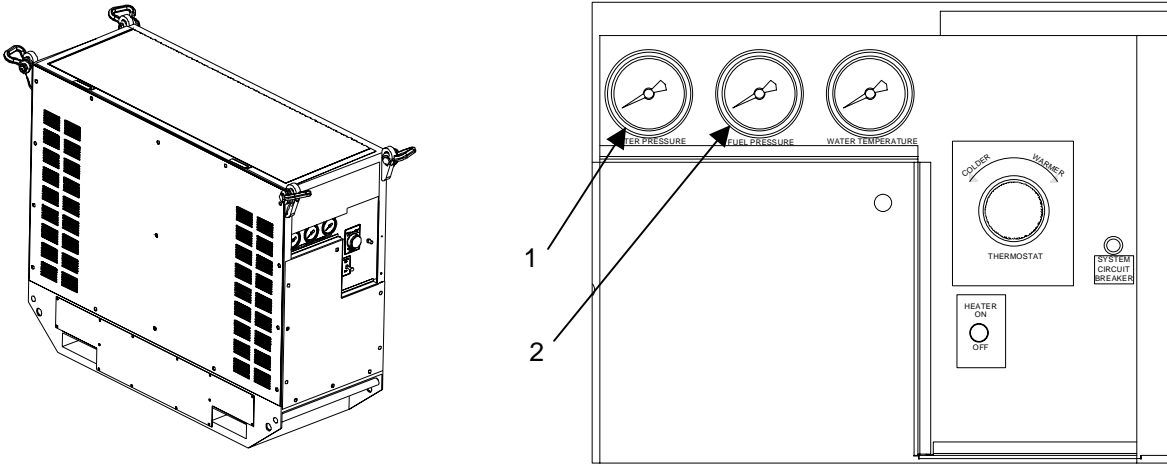

Table 1. OPERATOR'S CONTROLS AND INDICATORS - Continued



| Key | Control or Indicator | Function |
|-----|----------------------|---|
| 1 | WATER PRESSURE gage | <p style="text-align: center;">Water Heater Control Panel</p> <p>Indicates the pressure of the water being circulated through the boiler. Normal pressure indications are 60-120 psi. When the pressure exceeds 200 psi, the pressure relief valve (safety valve) on the boiler opens and relieves excess pressure.</p> <div style="text-align: center;">  <p>WATER PRESSURE</p> </div> |
| 2 | FUEL PRESSURE gage | <p>Indicates pressure of the fuel supply. Fuel pressure is normally 150 psi.</p> <div style="text-align: center;">  <p>FUEL PRESSURE</p> </div> |

Table 1. OPERATOR'S CONTROLS AND INDICATORS - Continued



| Key | Control or Indicator | Function |
|--|------------------------|---|
| Water Heater Control Panel - Continued | | |
| 3 | WATER TEMPERATURE gage | Indicates the temperature of the water in the boiler. |
| <p style="text-align: center;">WATER TEMPERATURE</p> | | |
| 4 | THERMOSTAT | Sets the desired operating water temperature manually. Select desired temperature by rotating knob. |
| <p style="text-align: center;">THERMOSTAT</p> <p style="text-align: center;">HEATER ON OFF</p> <p style="text-align: center;">SYSTEM CIRCUIT BREAKER</p> | | |

Table 1. OPERATOR'S CONTROLS AND INDICATORS - Continued

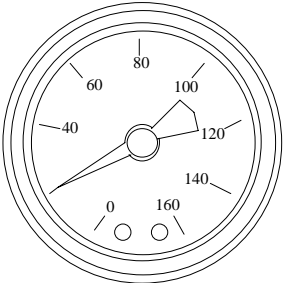
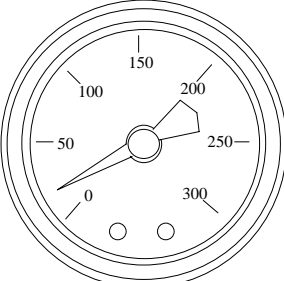
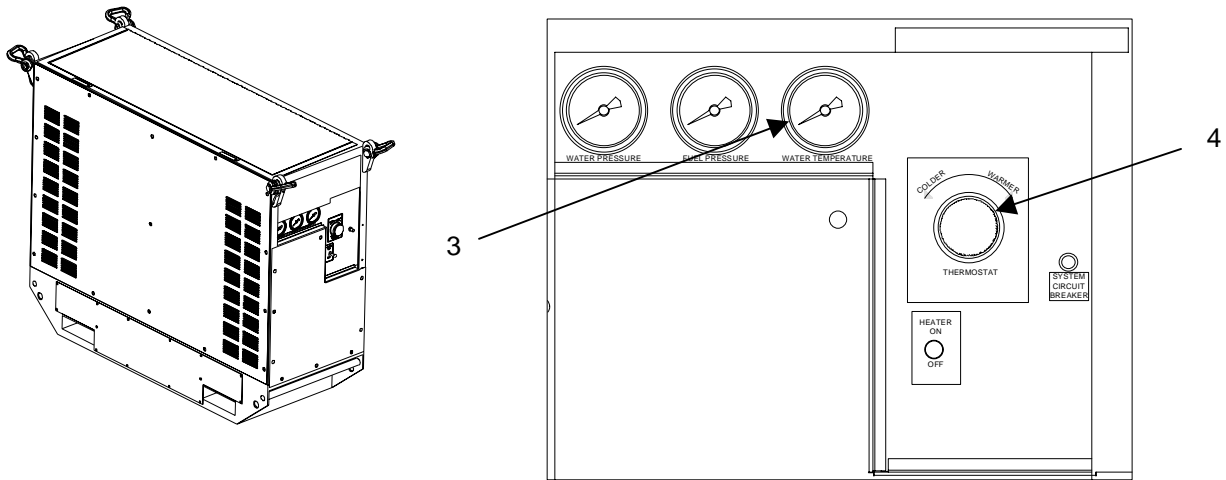
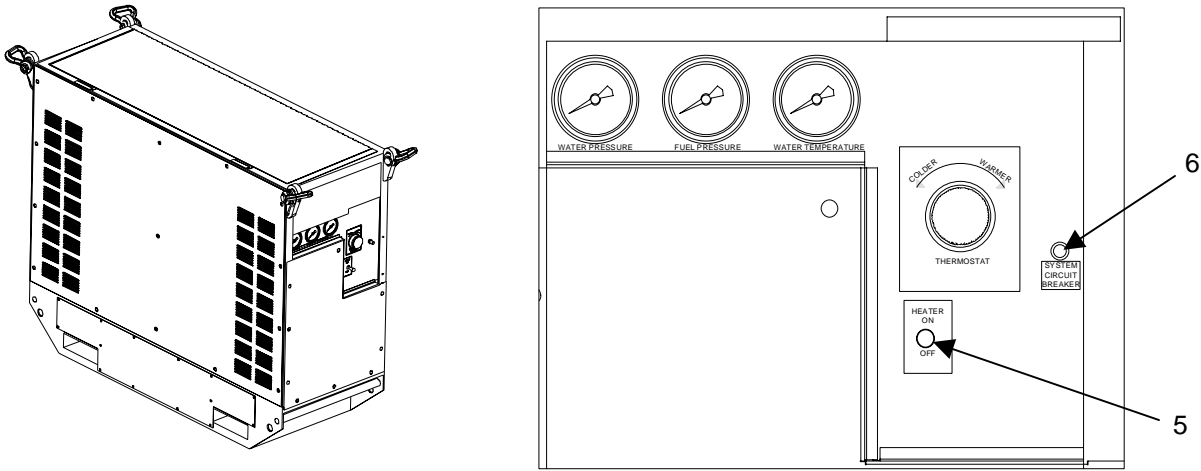

| Key | Control or Indicator | Function |
|--|-------------------------------|--|
| Water Heater Control Panel - Continued | | |
| 5 | HEATER ON/OFF switch | Controls operation of water heater. Placing this switch to HEATER ON energizes the blower motor, fan, fuel pump, and igniters. Turning the THERMOSTAT clockwise to a temperature above the tank's water temperature activates the fuel solenoid and admits fuel into the combustion chamber for burner ignition. |
| 6 | 15 Amp SYSTEM CIRCUIT BREAKER | Prevents damage to burner controls in case of electrical short circuit.  |

Table 1. OPERATOR'S CONTROLS AND INDICATORS - Continued



| Key | Control or Indicator | Function |
|--------------------|-----------------------------|--|
| Tank Unit Controls | | |
| 1 | Tank drain valve | Drains liquids or slurry from the tank. |
| 2 | Tank liquid level indicator | Located in the hopper-blender. The indicator is scaled from 100-447 gallons and shows the volume of liquid in the tank unit. |

END OF WORK PACKAGE

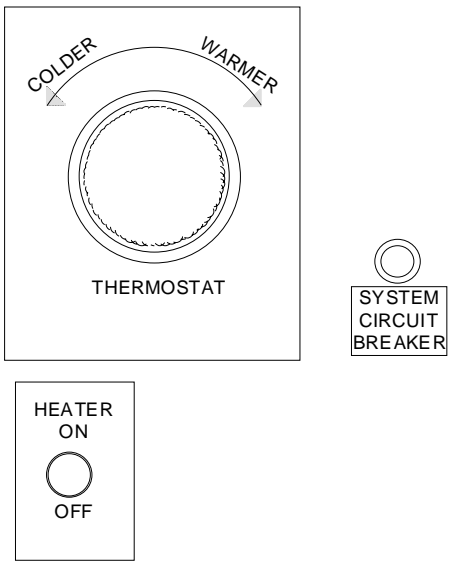
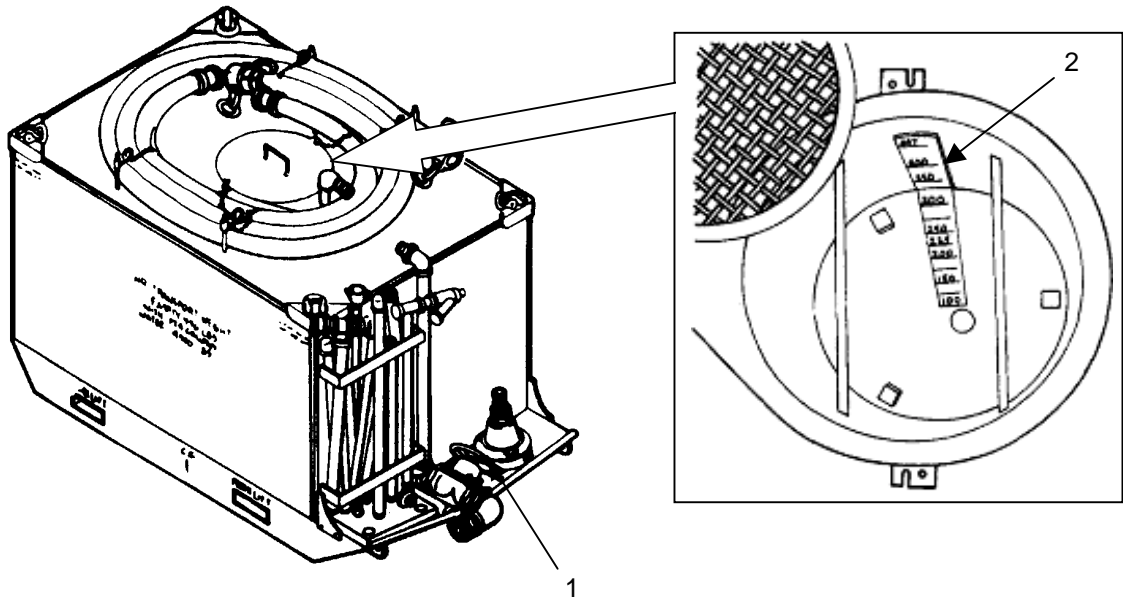
**OPERATOR
M12A1 DIESEL ENGINE DRIVEN DECONTAMINATION APPARATUS
NSN 4230-01-502-7224
OPERATION UNDER USUAL CONDITIONS:
ASSEMBLY AND PREPARATION FOR USE**

INITIAL SETUP:

References

WP 0007 00
WP 0012 00
WP 0016 00

SCOPE

This Work Package (WP) contains instructions for setting up the decontaminating apparatus under normal conditions of climate and service. Normal conditions are considered to be operation in warm weather + 50° F (+ 10° C) and above. For operation under unusual conditions, refer to WP 0012 00.

ASSEMBLY AND PREPARATION FOR USE

Perform the BEFORE PMCS procedures in Work Package 0016 00.

Fueling

WARNING

Wear protective gloves and eye protection when fueling the decontaminating apparatus.

Do not allow smoking when filling the fuel tank. Also do not permit open flame, sparks, or heated objects in the area.

Authorized fuel will be obtained only from authorized fuel services or fuel trucks. Siphoning fuel from vehicles is prohibited. Siphoning can cause static electricity or mouth and throat damage.

CAUTION

When filling the tank with fuel, be sure the dispenser hose nozzle on the container is clean and that the nozzle on the container contacts the filler neck on the sleeve to conduct static electricity away. Do not overfill the fuel tank. Room for expansion must be provided.

Check M12A1 labels before refueling. Use only JP-8 or diesel fuel. Using the wrong fuel could damage the equipment.

NOTE

Operating time for M12A1 DED is approximately 5 hours with a full tank.

ASSEMBLY AND PREPARATION FOR USE - Continued

Fueling - Continued

1. Wipe off the dirt around the filler pipe opening and the fuel tank cap. Remove the cap by turning it counterclockwise until it stops. Then press down, to allow the projections on the cap pressure plate to pass under the projections on the filler pipe neck ramp, and lift off the cap.

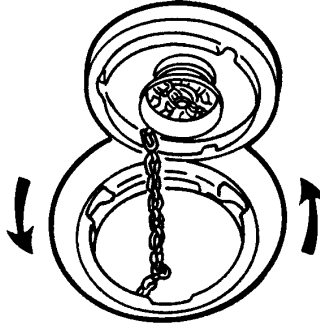

2. Fill the fuel tank until the fuel is approximately 1 inch below the filler neck.

WARNING

Running the M12A1 with the vent closed causes a vacuum inside the fuel tank. That can cause the engine to stop running. Removing the fuel tank cap too fast could let in-rushing air force fuel out of the tank. If the fuel spills on the engine, the M12A1 could catch fire, causing injury to personnel. The fuel tank cap vent stays open.

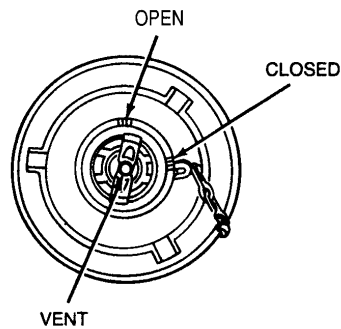

3. Make sure that the vent inside the cap is open and push the filler sleeve down. Place the cap on the filler neck and turn it clockwise until a stop is felt. Press down on the cap and turn farther to lock it.

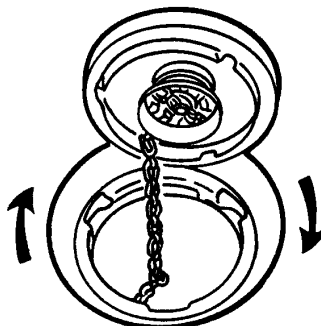

ASSEMBLY AND PREPARATION FOR USE - Continued**Setup****WARNING**

If the pump unit assembly and the water heater are operated in an enclosed area, the exhausts must be vented outside the enclosed area to prevent carbon monoxide poisoning. A chemical-biological mask does not protect against carbon monoxide fumes.

Keep clear of the exhaust stack during operation of the water heater. A chemical-protective mask does not protect against carbon monoxide gas.

Do not drape fuel hoses over exhaust stack. Failure to observe this warning could cause personnel injury.

CAUTION

Failure to securely connect fuel hoses could result in equipment damage. Assure proper connection.

1. Open the storage compartment door (1) on top of the water heater. Leave it open.
2. Remove the electrical power cable (2) and fuel hoses from the storage compartment.

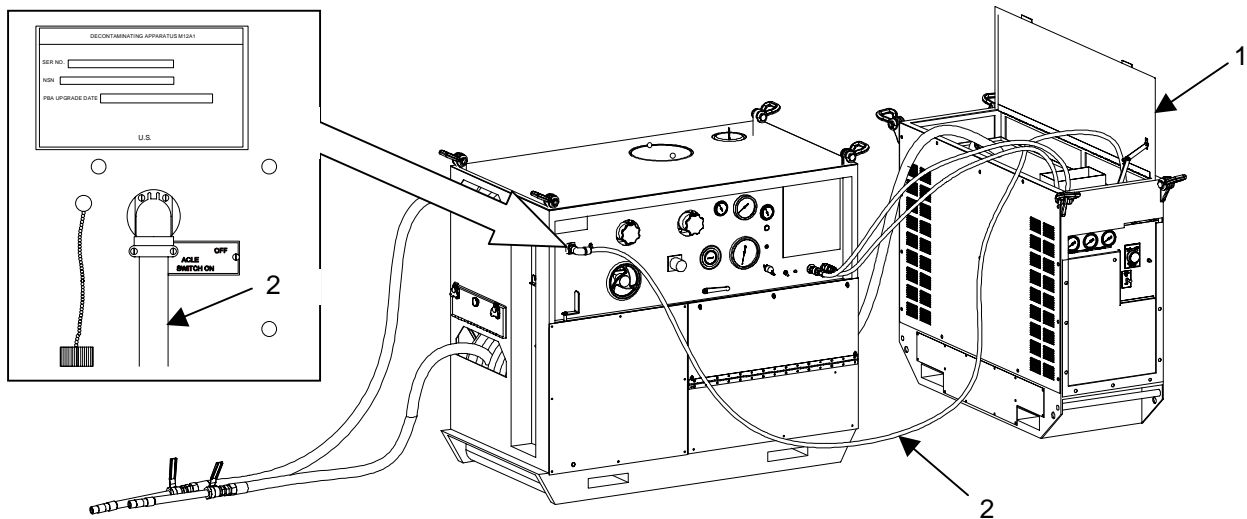

3. Remove the caps from the quick-disconnect couplings for the fuel supply and return lines on control panel. Connect the water heater fuel supply and return hose quick-disconnect coupling halves to the connectors on pump unit control panel.
4. Uncap the HEATER RECEPTACLE AND SWITCH socket on the control panel of the pump unit assembly and plug the free end of the power cable (2) into the socket. Make certain that the power cable does not pass over the exhaust stack.
5. Connect water hoses necessary for mode of operation. Open valves necessary for operation. Refer to STARTING PROCEDURE instruction plate on the pump unit or WP 0007 00 for the specific operation required.

END OF WORK PACKAGE

**OPERATOR
M12A1 DIESEL ENGINE DRIVEN DECONTAMINATION APPARATUS
NSN 4230-01-502-7224
OPERATION UNDER USUAL CONDITIONS:
STARTING AND STOPPING THE PUMP UNIT**

INITIAL SETUP:**Tools and Special Tools**

Collapsible pail (Page 0027 00-3, Table 2, item 6)

References

WP 0005 00

WP 0011 00

STARTING THE PUMP UNIT**WARNING**

The engine and water heater exhausts are lethal. Do not inhale these gases. A chemical-biological mask does not protect against carbon monoxide. When the decontaminating apparatus is to be operated, the exhaust gases must be vented away from the operator and outside of an enclosed area to prevent carbon monoxide poisoning.

To avoid injury or electrical shock, keep the HEATER RECEPTACLE AND SWITCH on the pump unit control panel to OFF when the water heater is not in use.

Wear hearing protection when operating the decontaminating apparatus.

STARTING THE PUMP UNIT - Continued

| STARTING PROCEDURE | | | | | | | | | | |
|--|--|---|-----------------------------|---|-------------------------------------|---------------------|----------|----------|----------|--|
| CAUTION: Do not operate pump dry or when discharge pressure is below 60 p.s.i.g. READ THE MANUAL | | | | | | | | | | |
| 1. Check all valve settings before starting and close all circuit breakers before starting. 2. If temperature is below 40 degrees Fahrenheit, activate engine pre-heater for 10 seconds. 3. Turn starting switch to start. 4. When engine starts, release start switch to run position. 5. Check all gages to insure proper operation. 6. Prime Detergent Valve #4 must be closed when Prime-Detergent tank is empty. | | | | | | | | | | |
| | | | | | | | | | | VALVE POSITION O - OPEN X - CLOSED |
| OPERATION NO. | OPERATION | | PREVIOUS OPERATION REQUIRED | SUCTION HOSE TO DISCHARGE | DISCHARGE HOSE TO T-TANK CONNECTION | VALVE #1 CONNECTION | VALVE #2 | VALVE #3 | VALVE #4 | REMARKS |
| 1. | PRIME DRY PUMP TURN ON FUEL SUPPLY START (SEE PROCEDURE) | -- | S | ON | CAP | O | X | X | O | *TO TANK AGITATOR CONNECT ONE INCH HOSE **OPEN FOR 1 MINUTE BEFORE STARTING, THEN CLOSE TO HALFWAY FOR REMAINDER OF PRIME OPERATION (SEE 6 ABOVE) |
| 2. | FILL TANK WITH WATER | 1 | S | ON | CAP | O | X | X | X | *TO AGITATOR CONNECT ONE INCH HOSE |
| 3. | BLEND SLURRY | 2 | T | ON | CAP | O | X | X | X | *TO TANK BLENDER ADD ANTISET THEN ADD STB. |
| 4. | AGITATE SLURRY | 3 | T | ON | CAP | O | X | X | X | *TO TANK AGITATOR |
| 5. | DISCHARGE UPPER REEL | 2,3 | T | CAP | CAP | O | X | O | X | |
| | SLURRY LOWER REEL | 2,3 | T | CAP | CAP | O | O | X | X | |
| 6. | DISCHARGE UPPER REEL | 1 | S/ T | CAP | CAP | O | X | O | X | |
| | WATER LOWER REEL | 1 | S/ T | CAP | CAP | O | O | X | X | |
| 7. | DISCHARGE UPPER REEL | 1 | S/ T | ON | ON | X | X | O | X | *FROM HEATER **TO HEATER |
| | HOT WATER LOWER REEL | 1 | S/ T | ON | ON | X | O | X | X | *FROM HEATER **TO HEATER |
| 8. | PUMP WATER ONLY TO HEATER OR OTHER | 1 | S/ T | ON | CAP | O | X | X | X | *TO HEATER OR OTHER |
| 9. | DISCHARGE FOAM UPPER REEL | 1 | S/ T | CAP | CAP | O | X | O | O | *ADJUST FOR PROPER BLEND |
| | OR DETERGENT LOWER REEL | 1 | S/ T | CAP | CAP | O | O | X | O | *ADJUST FOR PROPER BLEND |
| 10. | FLUSH SYSTEM | 1 | S | OPEN TANK DRAIN AND FLUSH TANK THOROUGHLY, THEN OPEN PUMP DRAIN AND FLUSH HOSE REELS AND DISCHARGE CONNECTIONS (SEE MANUAL) | | | | | | |
| 11. | SHUTDOWN PROCEDURE | TURN START SWITCH TO OFF POSITION. CAP ALL PIPES AND CLOSE ALL VALVES EXCEPT PUMP DRAIN VALVE. OPEN ALL CIRCUIT BREAKERS. | | | | | | | | |

NOTE

The procedure listed below is reflected as the starting procedure on the STARTING PROCEDURE instruction plate. This procedure is performed after all connections are made for the specific operation and the pipes not used are capped. See the instruction plate for specific operation and connections.

1. Make sure hoses are connected properly for the desired mode of operation. Refer to STARTING PROCEDURE instruction plate or following paragraphs for the specific operation required. (The STARTING PROCEDURE instruction plate is on the control panel of the pump unit.)

STARTING THE PUMP UNIT - Continued

CAUTION

Rear hinged panel must be open to operate. Operation with panel closed may cause excessive heat and equipment damage.

2. Close the pump DRAIN valve (1). Using the collapsible pail, fill the prime-detergent tank with water.
3. Open VALVE NO. 4 PRIME (2). This allows water from the prime-detergent tank to fill the pump cavity. Make sure water is present in the cavity by opening the pump DRAIN valve briefly. (This valve is in the pump drain piping.) Allow some water to run out. Close the pump DRAIN valve.

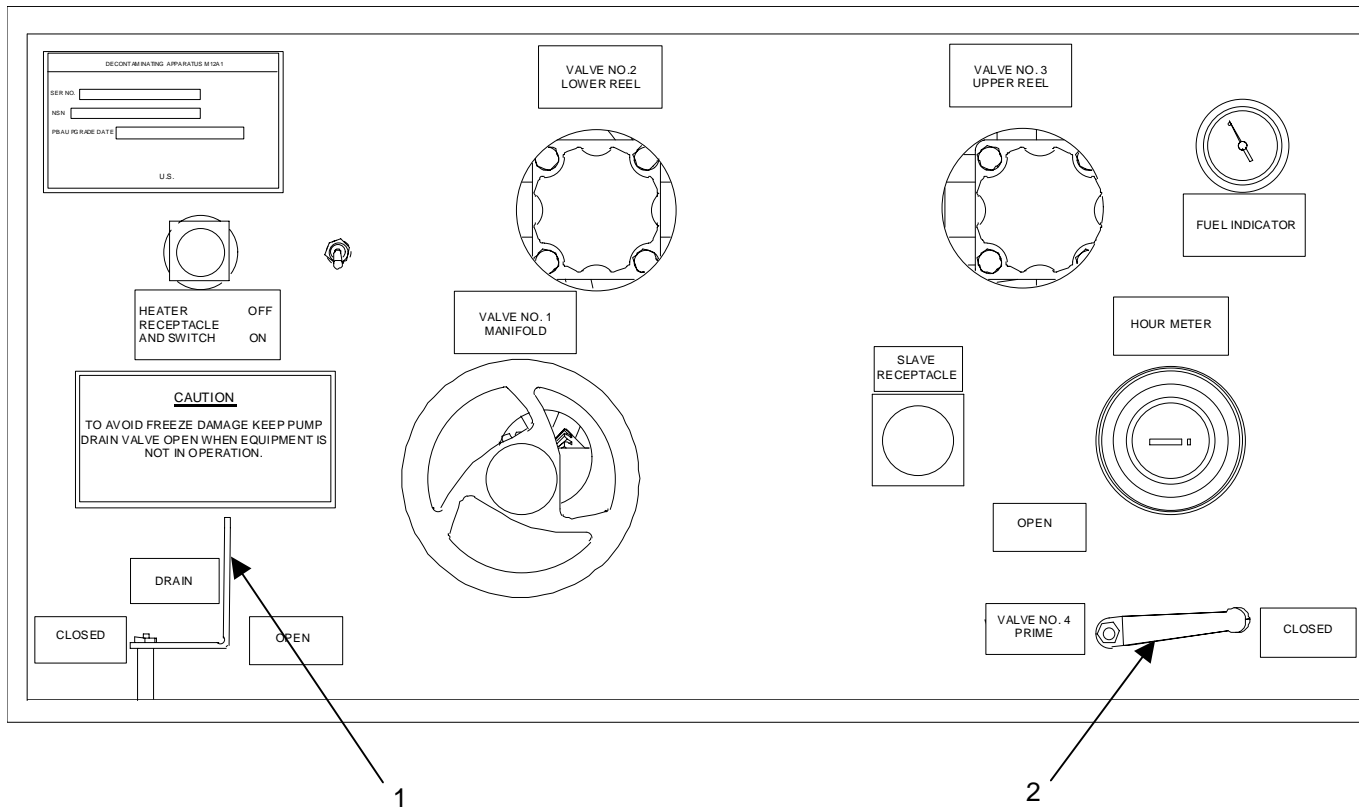

4. Open the rear panel prior to operating.
5. Open the valves needed for the operation by referring to the STARTING PROCEDURE instruction plate or the following paragraphs for the specific operation required.
6. Perform the pump unit checklist (Table 1).

STARTING THE PUMP UNIT - Continued

Table 1. Pump Unit Checklist.

| Item No. | Item to be Inspected | Procedure |
|----------|----------------------|--|
| 1 | Oil level | Pull dipstick from engine to check oil level. Add oil, if necessary. Replace dipstick. |
| 2 | Prime-detergent tank | Remove tank lid. Check that prime-detergent tank is full of water. Add water, if necessary. Replace tank lid. |
| 3 | VALVE NO. 4 PRIME | Check that valve handle is OPEN. |
| 4 | Pump DRAIN valve | Bleed air from the pump with the pump DRAIN valve. Then close valve. |
| 5 | Fuel tank | Remove fuel tank cap (3). See that adequate fuel is in fuel tank. Fill with JP-8 or diesel fuel, if necessary (see fueling, Page 0005 00-1). Before replacing cap, ensure that vent is open. |
| 6 | Diesel Fuel | See that the lever on the fuel valve (4) beneath the fuel tank is open (handle is in line with valve). |
| 7 | Rear Lower Panel | See that panel is open before operating. |

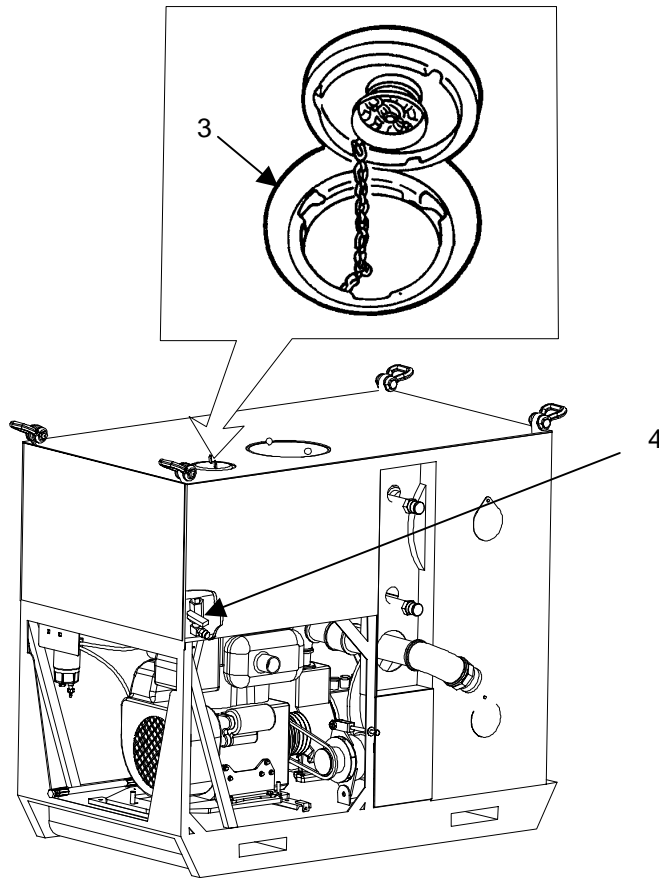

STARTING THE PUMP UNIT - Continued

7. Start the engine.
 - a. Verify that fuel valve on fuel tank is open.
 - b. Move IGNITION SWITCH (5) to the RUN position.
 - c. Check that LOW OIL PRESSURE LIGHT (6) comes on.
 - d. Check that VOLTMETER (7) needle is in the green range.

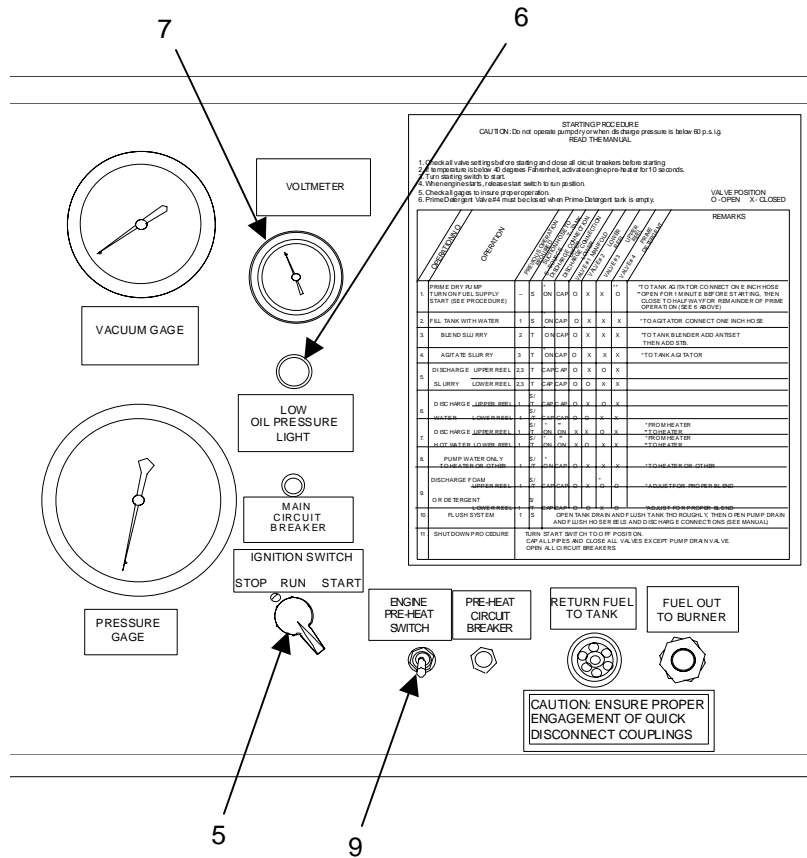

- e. Check that HEATER RECEPTACLE switch (8) is OFF.

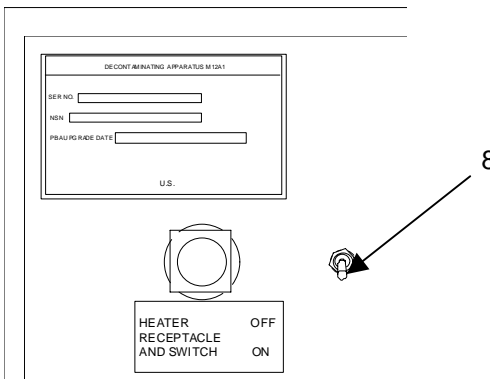

- f. If the temperature is 40° F (4.44° C) or lower, hold the ENGINE PRE-HEAT SWITCH (9) for 30-45 seconds.

STARTING THE PUMP UNIT - Continued

g. Turn the IGNITION switch (5) to the START position. Release switch when the engine starts. Do not allow the engine to crank for more than 10 seconds without letting the starter cool down. Check to see that the LOW OIL PRESSURE LIGHT (6) goes out when the engine starts. If not, shut down immediately.

h. If the temperature is below 40°F (4.44°C), operate the ENGINE PRE-HEAT SWITCH (9) for an additional minute or until the engine begins running smoothly.

i. At first, the water PRESSURE GAGE (10) may indicate zero and the VACUUM GAGE (11) may indicate from 0 to 15 inches of mercury depending on the height of the pump above the level of water. When the pump is fully primed, the sound of the pump will change noticeably and the water PRESSURE GAGE should indicate between 60 and 120 psi. (90 psi is a normal reading.) If pressure gage does not show pressure, stop engine and check hose connections and valve settings.

CAUTION

Close VALVE NO. 4 PRIME before the prime-detergent tank is empty. If the valve is not closed, all vacuum or pressure is lost due to air being drawn into the pump from the prime-detergent tank.

8. Close VALVE NO. 4 PRIME (2) immediately when the pump is fully primed.

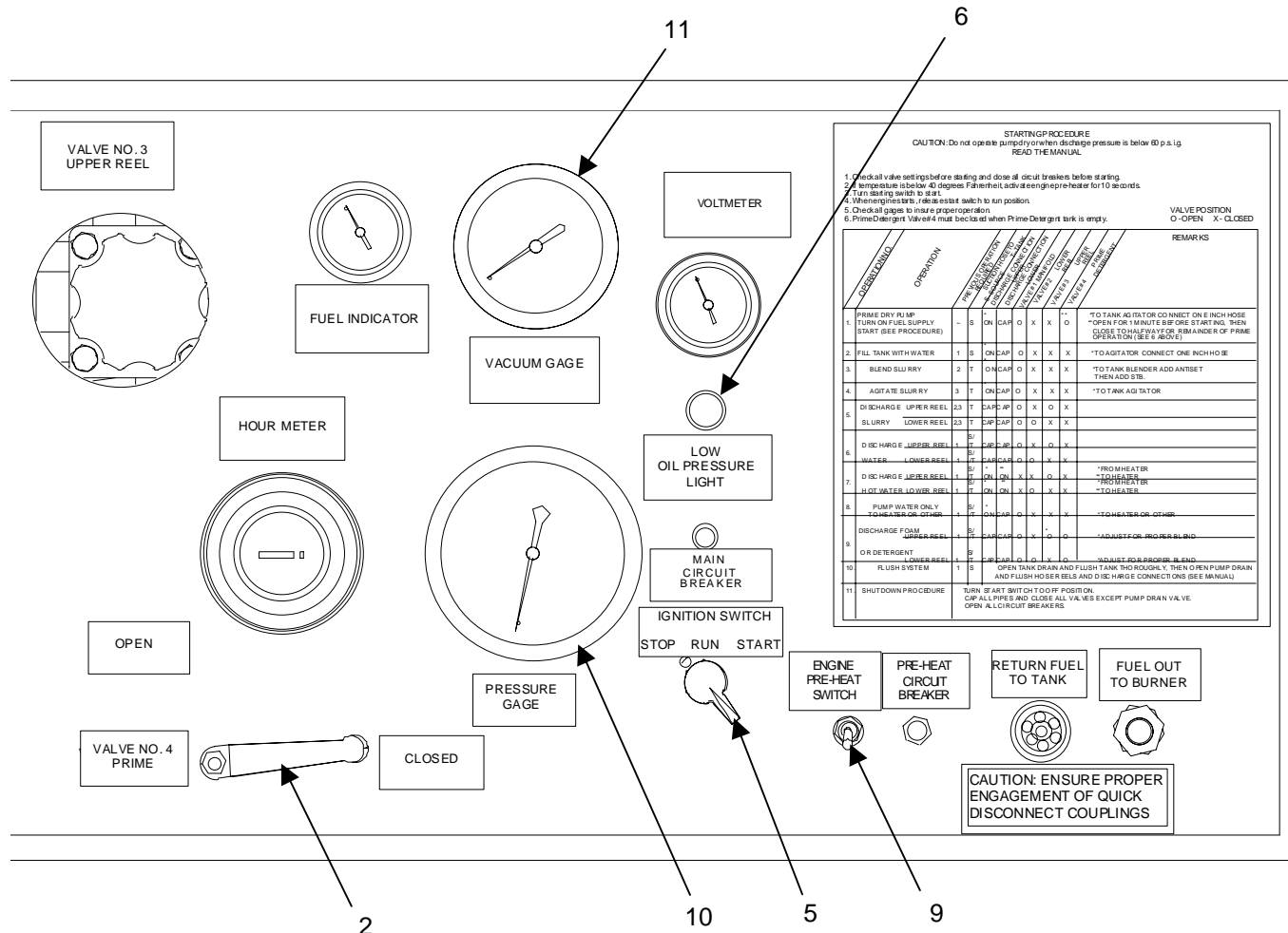

STOPPING THE PUMP UNIT

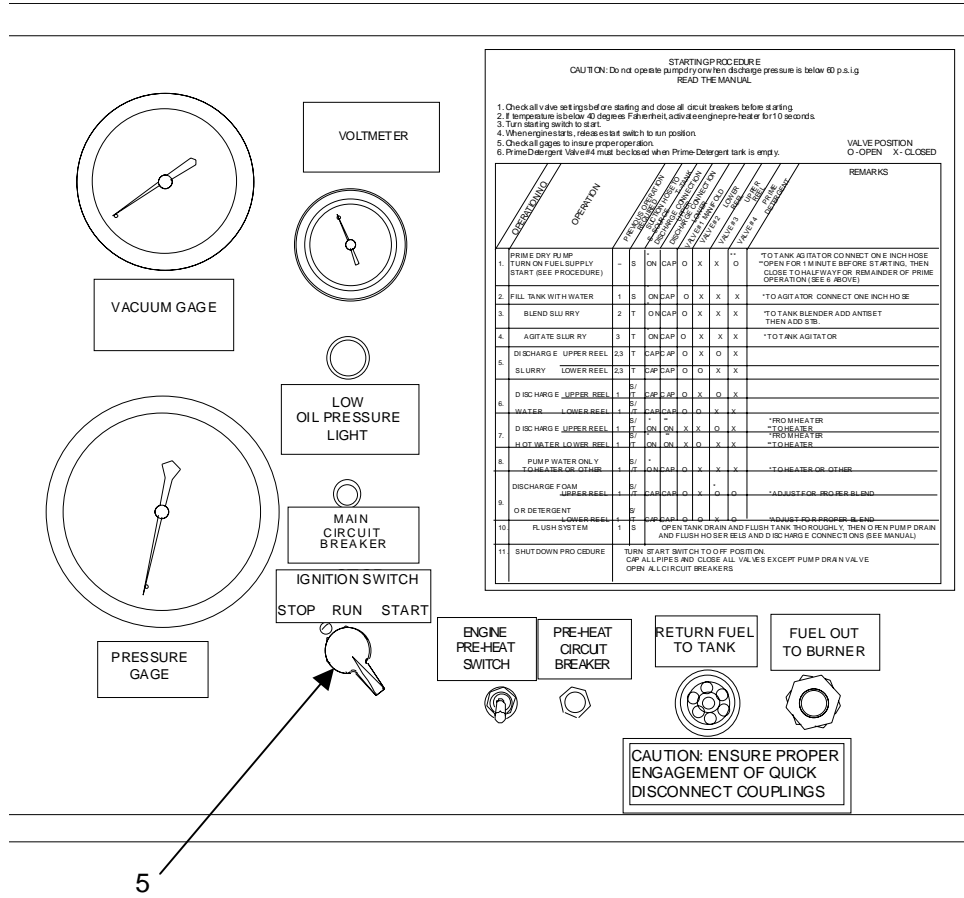

1. Turn IGNITION switch (5) from the RUN position to the STOP position. If engine does not stop, actuate manual stop lever (12) on engine.

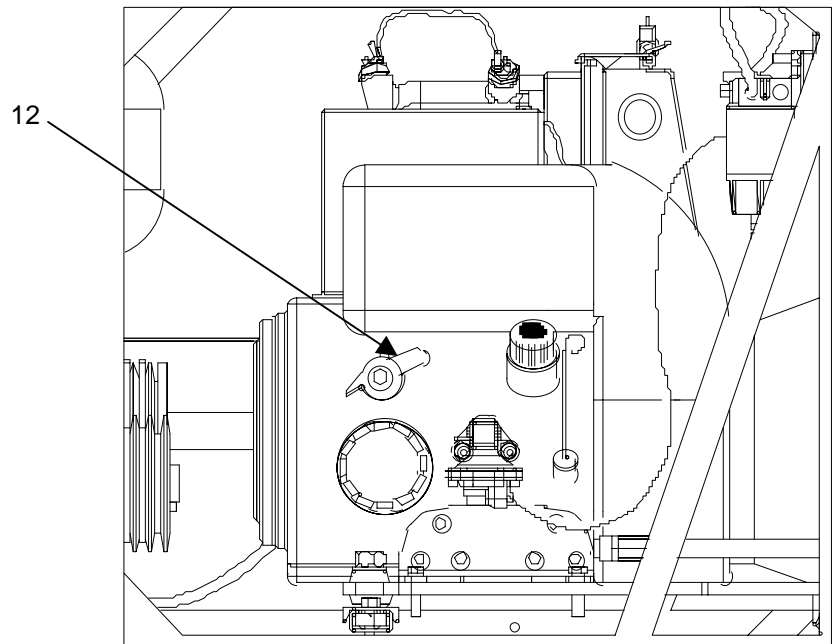

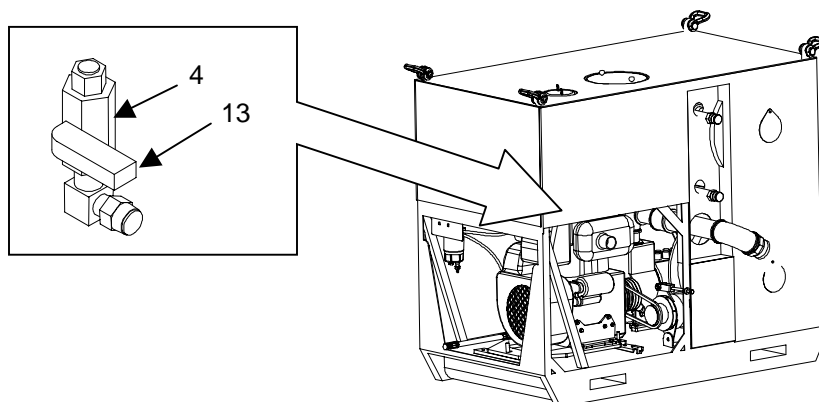
STOPPING THE PUMP UNIT - Continued

2. If this is the end of your mission, turn the lever (13) on the fuel valve (4) beneath the fuel tank to closed position, as shown.
3. Close VALVES NO. 1, 2, and 3. Make sure VALVE NO. 4 PRIME is closed.
4. If the tank unit is used, close the tank drain valve on the tank unit assembly. Disconnect all hoses except the water heater hose (15) from the top of the heater. Open the pump DRAIN valve to drain liquid from the piping and pump. Cap all pipes.

CAUTION

Be sure that water heater is cool before stowing the main electrical power cable and fuel lines in the storage compartment.

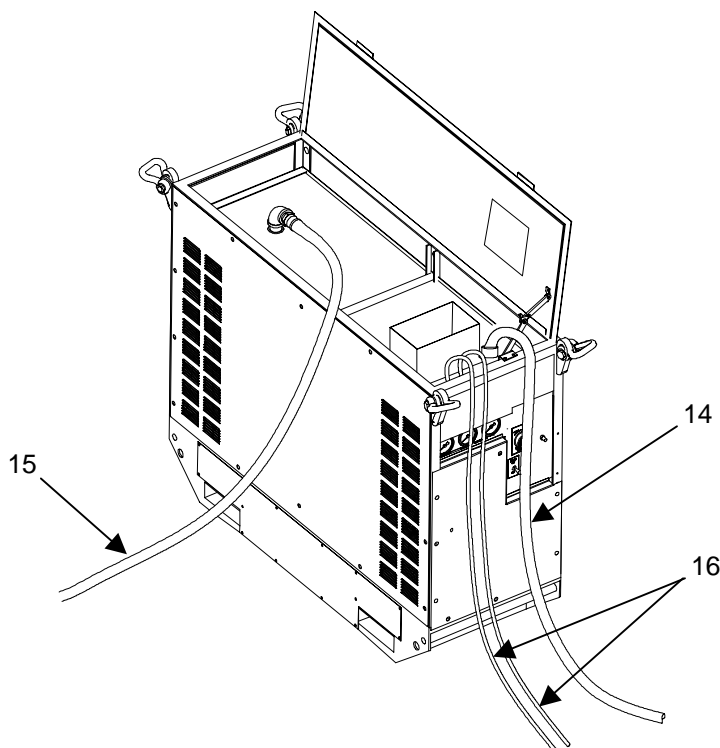

5. Stow electrical cable (14). Disconnect the electrical cable leading from the water heater at the connector on the pump unit assembly control panel. Stow the cable in the storage compartment.

STOPPING THE PUMP UNIT - Continued

6. Stow water hoses (15). Disconnect hoses from pump unit and stow in water heater stowage compartment.
7. Stow fuel hoses (16). Disconnect hoses from pump unit and stow in water heater stowage compartment.
8. After the spraying mission is complete, flush, drain, clean, and stow the apparatus according to the applicable procedure in WP 0011 00.

END OF WORK PACKAGE

OPERATOR
M12A1 DIESEL ENGINE DRIVEN DECONTAMINATION APPARATUS
NSN 4230-01-502-7224
OPERATION UNDER USUAL CONDITIONS:
STARTING AND STOPPING THE WATER HEATER AND SPRAYING WATER

INITIAL SETUP:

References

- WP 0006 00
- WP 0011 00
- WP 0014 00

SPRAYING WATER FROM A NATURAL SOURCE

| OPERATION NO. | OPERATION | PREVIOUS OPERATION REQUIRED | SUCTION HOSE TO SOURCE | DISCHARGE TO TANK | DISCHARGE CONNECTION | VALVE #1 | VALVE #2 | VALVE #3 | VALVE #4 | PRIME DEAGENT | REMARKS |
|---------------|----------------------|-----------------------------|------------------------|-------------------|----------------------|----------|----------|----------|----------|---------------|---------|
| | | | | | | | | | | | |
| 6 | DISCHARGE UPPER REEL | 1 | S/T | CAP | CAP | O | X | O | X | | |
| | WATER LOWER REEL | 1 | S/T | CAP | CAP | O | O | X | X | | |

1. Follow operation number 6 on the STARTING PROCEDURE instruction plate.

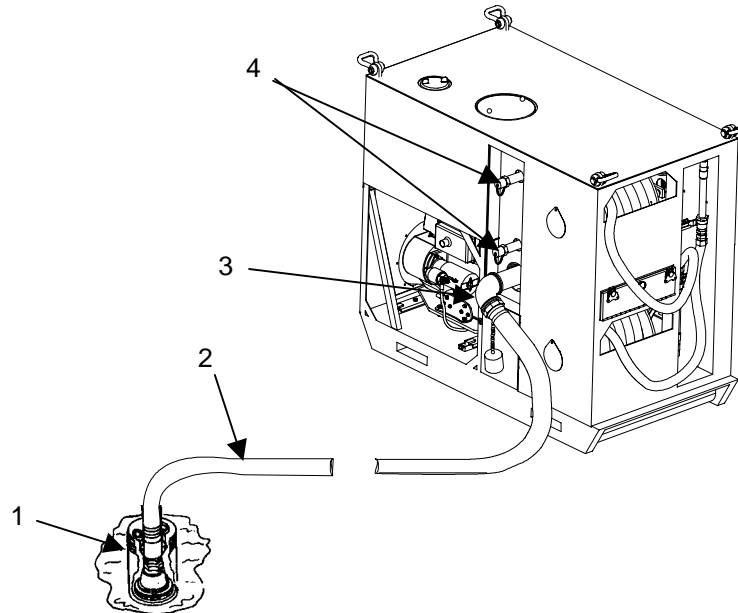

2. Connect the foot valve (1) to the suction hose (2). Connect the suction hose (2) to the pump unit (3). Cap the upper and lower discharge connections (4). Submerge foot valve in water source.

SPRAYING WATER FROM A NATURAL SOURCE - Continued

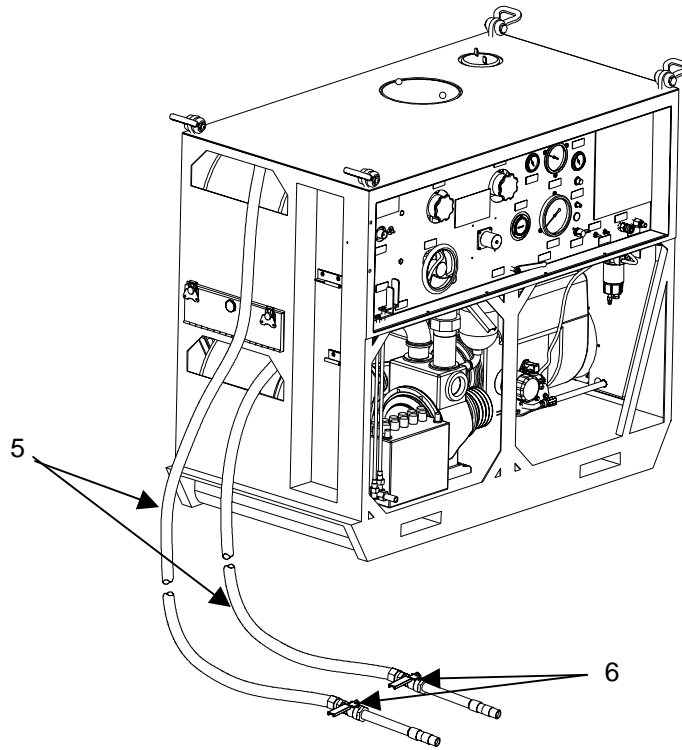

3. Prime the pump and start the pump unit (Page 0006 00-1). Unreel the discharge hoses (5) from the two hose reels.
4. To spray from the upper reel, open VALVES NO. 1 and 3. To spray from the lower reel, open VALVES NO. 1 and 2. Open ball valve (6) on gun assembly to spray. Open the slurry nozzle's orifice and deflector assembly to produce the desired spray pattern.

NOTE

The pump discharge PRESSURE GAGE should indicate approximately 105 psi while spraying.

5. After the spraying mission is complete, stop the pump unit (Page 0006 00-7). Clean and store the apparatus according to applicable procedure listed in WP 0011 00.

SPRAYING WATER FROM TANK

| OPERATION NO. | OPERATION | PREVIOUS OPERATION REQUIREMENT | SUCTION SOURCE | DISCHARGE HOSE TO | TANK | VALVE POSITION | | | | REMARKS |
|---------------|----------------------|-----------------------------------|----------------|-------------------|------|----------------------|------------------------|-------------------|---------------------|---------|
| | | | | | | DISCHARGE CONNECTION | DIRTY-WATER CONNECTION | VALVE #1 MANIFOLD | VALVE #2 LOWER REEL | |
| | | | | | | O - OPEN | X - CLOSED | | | |
| 6 | DISCHARGE UPPER REEL | 1 | S/T | CAP | CAP | O | X | O | X | |
| | WATER LOWER REEL | 1 | S/T | CAP | CAP | O | O | X | X | |

1. Follow operation number 6 on the STARTING PROCEDURE instruction plate.

SPRAYING WATER FROM TANK - Continued

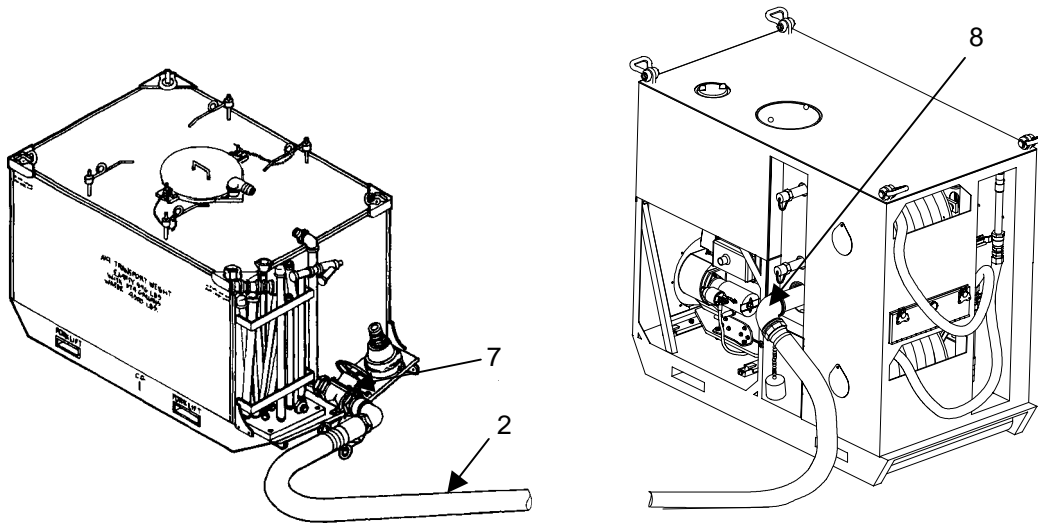

2. Connect one end of suction hose (2) to the tank drain valve (7) and the other end to the pump unit connection (8).
3. Cap the upper and lower discharge connection.
4. Open tank drain valve (7).
5. Prime the pump and start the pump unit (Page 0006 00-1). Unreel the discharge hoses (5) from the two hose reels.
6. To spray from the upper reel, open VALVES NO. 1 and 3. To spray from the lower reel, open VALVES NO. 1 and 2. Open valve on gun assembly to spray. Open the slurry nozzle's orifice and deflector assembly to produce the desired spray pattern.

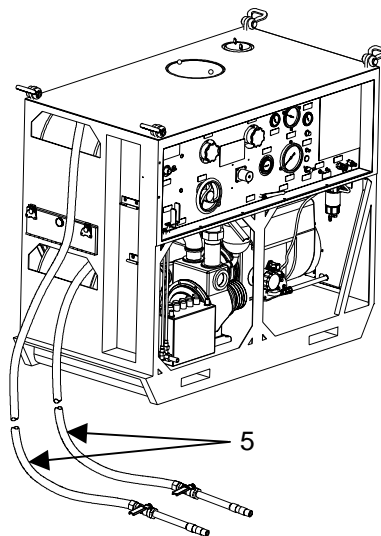

NOTE

The pump discharge pressure gage should indicate approximately 105 psi while spraying.

7. After the spraying mission is complete, stop the pump unit (Page 0006 00-7). Clean and store the apparatus according to applicable procedure listed in WP 0011 00.

LOADING TANK FROM A PRESSURE SOURCE

CAUTION

Always use the cleanest water available. Grit or dirt in water under pressure will damage the pump and hose nozzles.

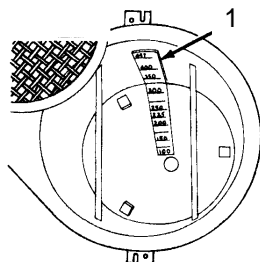

NOTE

The working capacity of the tank unit is approximately 447 gallons. When water only is to be loaded, fill the tank to the 447 gallon capacity. When STB decontaminating agent is to be added, fill the tank with only 225 gallons of water. If necessary, remove screen to read the tank liquid level indicator (1).

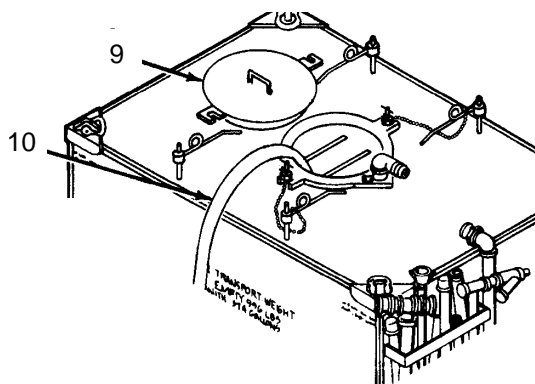

1. Remove cover (9). Load water from a hydrant or tank truck by inserting a hose (10) (not part of the decontaminating apparatus) in the hopper-blender.

NOTE

An alternate method of filling from a pressure source is to use the suction hose provided with the decontaminating apparatus. First, attach one end to the tank drain valve. Then, using a suitable adapter (not part of the decontaminating apparatus), connect the opposite end of the suction hose to the pressure source. Open the tank drain valve and monitor the filling progress on the tank liquid level indicator because it can be very rapid.

LOADING TANK FROM A NATURAL SOURCE

NOTE

If the height from the natural water source to the pump is not more than 15 feet, water can be loaded from a stream, pond, or other natural source by using the suction hose and foot valve assembly.

STARTING PROCEDURE
 CAUTION: Do not operate pump dry or when discharge pressure is below 60 p.s.i.g.
 READ THE MANUAL

1. Check all valve settings before starting and close all circuit breakers before starting.
2. If temperature is below 40 degrees Fahrenheit, activate engine pre-heater for 10 seconds.
3. Turn starting switch to start.
4. When engine starts, release start switch to run position.
5. Check all gages to insure proper operation.
6. Prime Detergent Valve #4 must be closed when Prime-Detergent tank is empty.

VALVE POSITION
 O - OPEN X - CLOSED

| OPERATION NO. | OPERATION | PREVIOUS OPERATION REQUIRED | SUCTION HOSE TO DISCHARGE | UPPER TANK CONNECTION | LOWER CONNECTION | MANIFOLD | LOWER REEL | UPPER REEL | PRIME DETERGENT | REMARKS |
|---------------|----------------------|-----------------------------|---------------------------|-----------------------|------------------|----------|------------|------------|-----------------|------------------------------------|
| 2. | FILL TANK WITH WATER | 1 | S | ON CAP | O | X | X | X | | *TO AGITATOR CONNECT ONE INCH HOSE |

1. Follow operation number 2 on the STARTING PROCEDURE instruction plate.

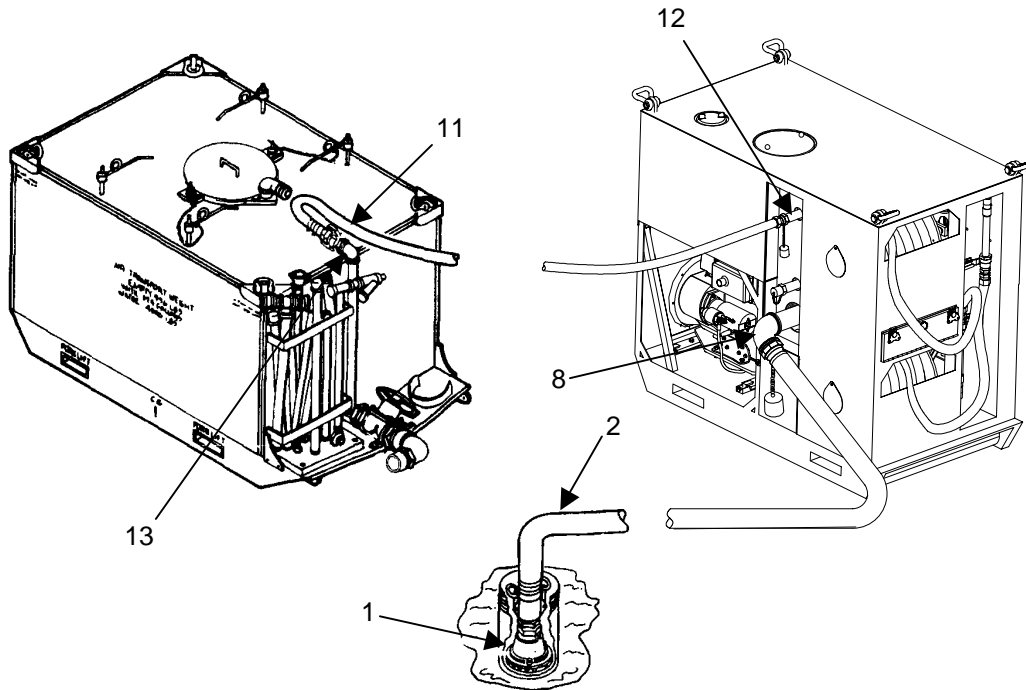

2. Connect one end of the suction hose (2) to the pump unit connection (8) and the other end to the foot valve assembly (1). When practical, place the foot valve (1) in an empty STB decontaminating drum or equivalent and immerse the foot valve.

3. Couple one end of the agitator-blender hose (11) to the pump unit upper discharge pump connection (12) and the other end to the agitator connector (13) on the tank unit.

LOADING TANK FROM A NATURAL SOURCE - Continued

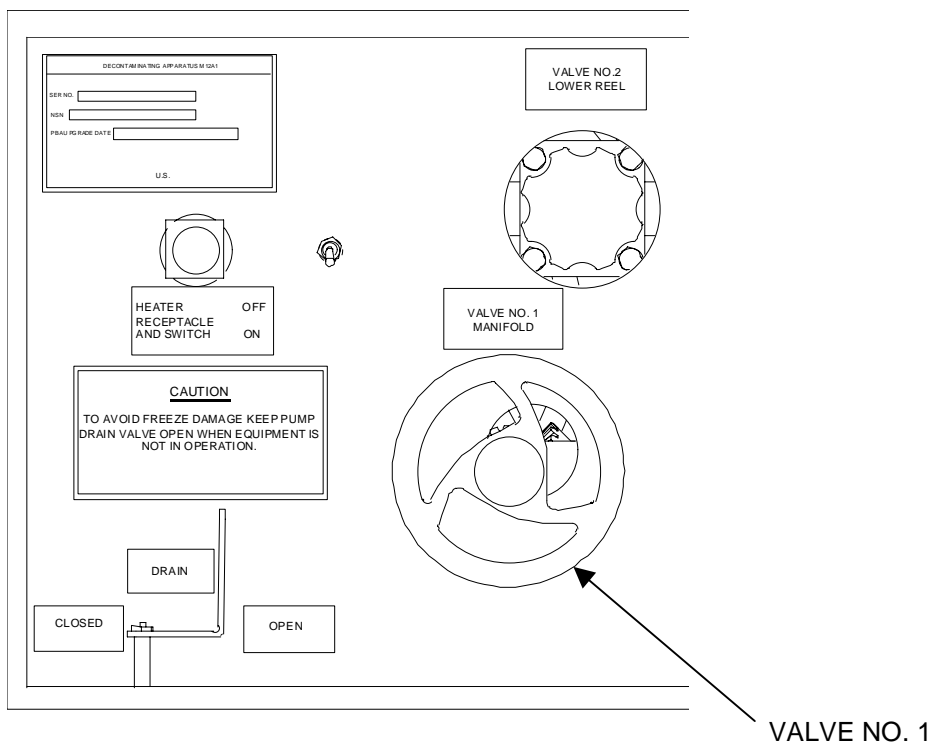

4. Open VALVE NO. 1.
5. Prime the pump, start the pump unit (Page 0006 00-1) and fill the tank with water.

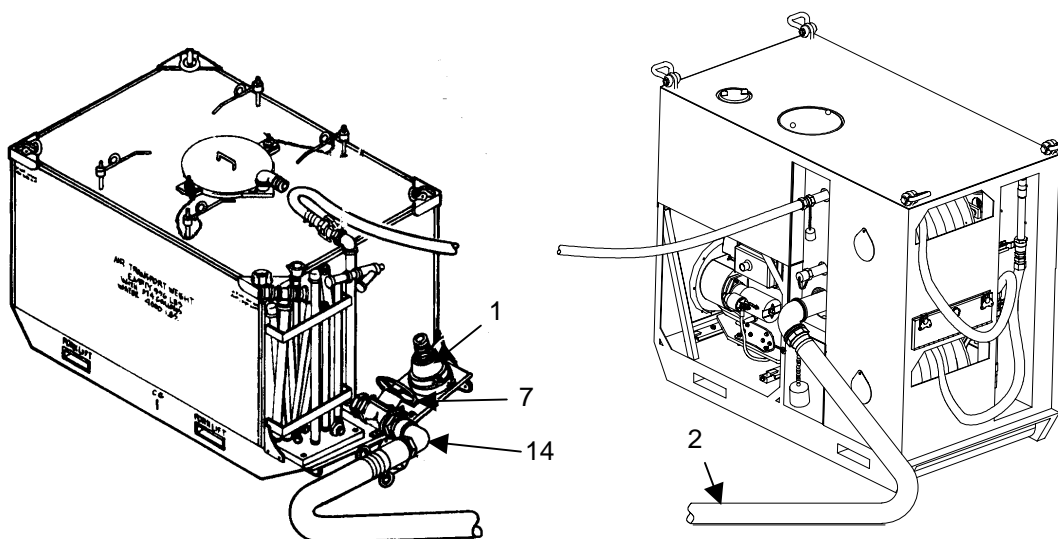

6. After loading the tank with water, stop the pump unit (Page 0006 00-7). Disconnect suction hose (2) from foot valve assembly (1). (Stow the foot valve assembly.) Connect the free end of the suction hose (2) to the tank drain quick-disconnect coupling half (14). Open the tank drain valve (7).

HEATING WATER

CAUTION

Circulate only clean water through the water heater. Do not circulate slurry or any other mixture through the water heater. Do not use the heater when metering fluids into the pump from the prime-detergent tank.

The updated heater unit burns JP-8 or diesel fuel only. This fuel is drawn from fuel tank on pump unit. Using the wrong fuel could damage the equipment.

To prevent damage to water heater, be sure that water is flowing through heater unit prior to turning on the heater controls. Be sure that VALVE NO. 1 is closed (turned fully clockwise). This ensures that the boiler is filled with water and that all air is out of the lines prior to heating water.

One end of the power cable passes through the strain relief and is connected inside the control box. Do not disconnect this end of the power cable. Be careful not to drop electrical connector on power cable or quick-disconnect on fuel hoses in mud.

NOTE

An operator must be in attendance at all times during operation of the water heater.

Two procedures may be used for heating water depending on if water is to be drawn from a natural source, heated, and discharged or if water in the tank is to be heated. Generally if water is heated in the tank, higher water temperatures can be reached since the water can pass through the water heater more than once.

The heater operating instruction plate provides additional heater operating instructions.

HEATING WATER – Continued

1. Refer to page 0005 00-3 to set up pump unit and water heater for operation.

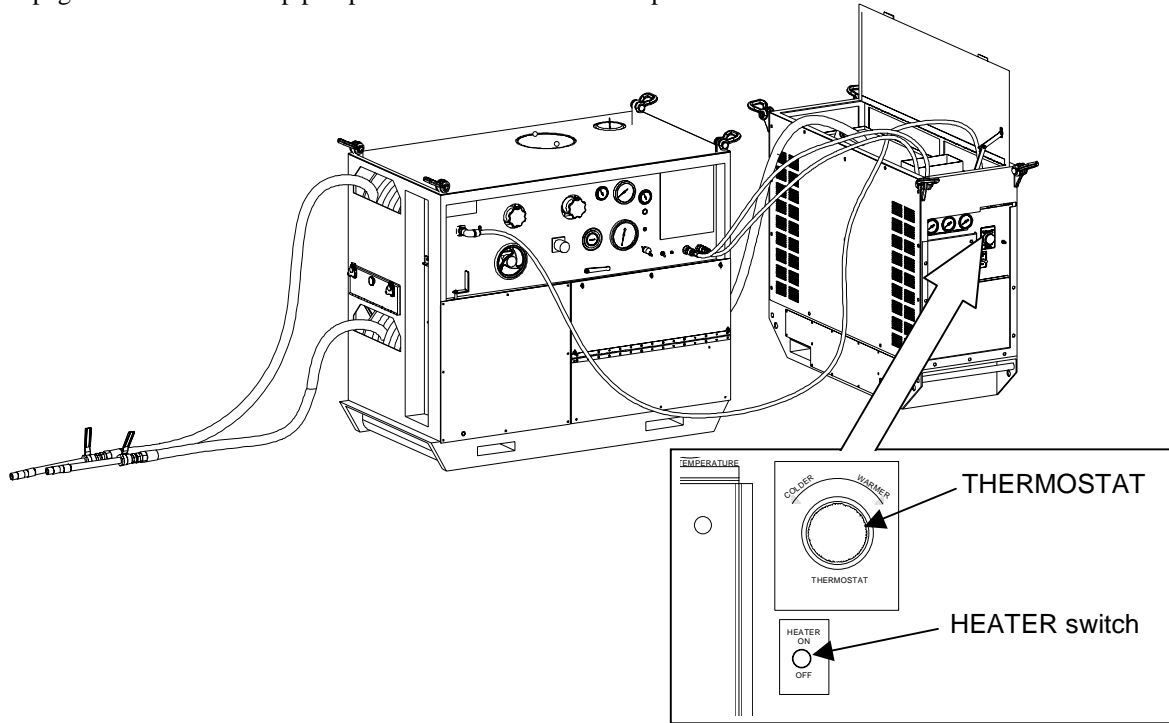

2. Make sure both the HEATER switch and THERMOSTAT on the water heater are in the OFF position. Make sure the HEATER RECEPTACLE AND SWITCH (15) on the pump unit is in OFF position.

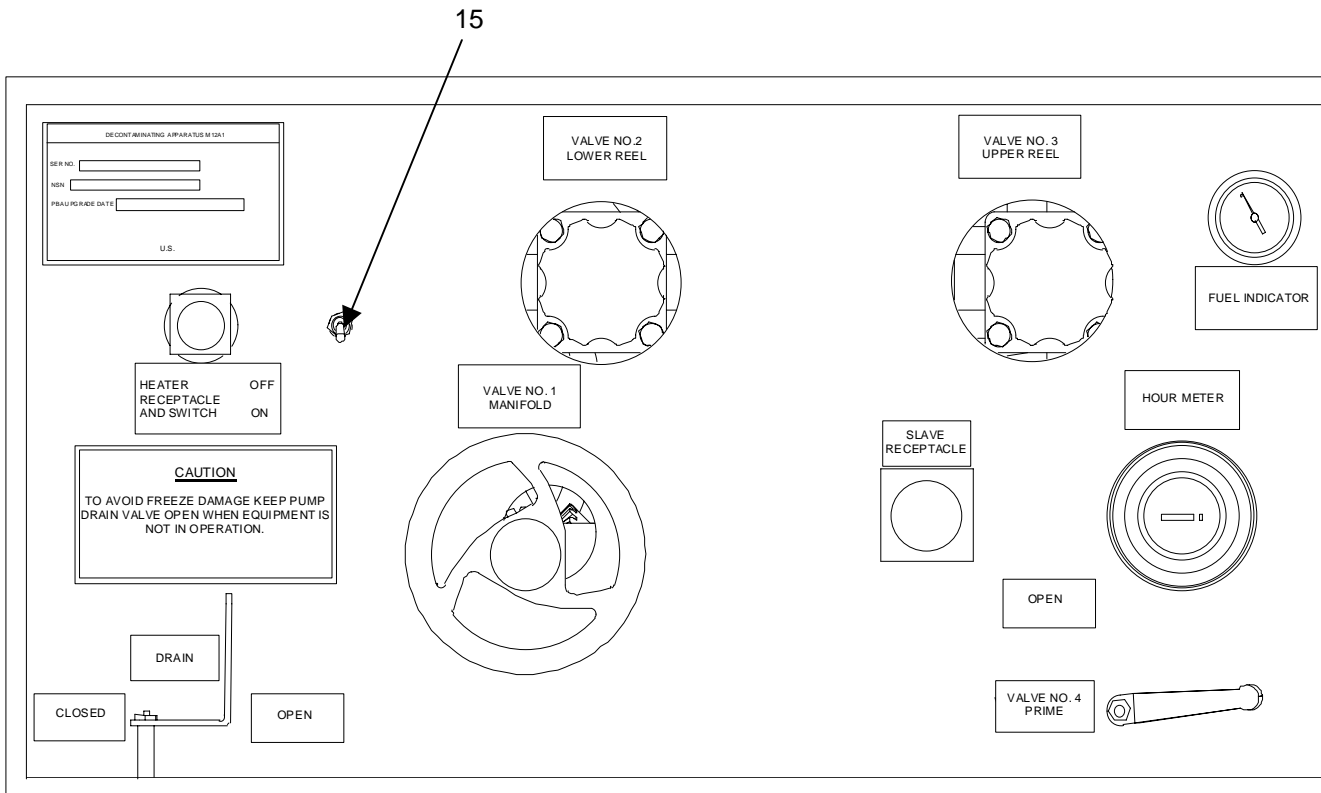

HEATING WATER – Continued

3. Prime the pump. Start the pump unit (Page 0006 00-1). Place HEATER RECEPTACLE AND SWITCH to ON. Pump water heater full of clean water. Operate HEATER ON for at least 2 minutes before turning the THERMOSTAT to selected temperature setting.

WARNING

If the water heater does not ignite in 10 seconds, turn the heater THERMOSTAT to OFF. Do not attempt to start the water heater. Refer to Work Package 0014 00 for operator troubleshooting procedures. Remove electrical power by placing the HEATER RECEPTACLE AND SWITCH on the pump unit to OFF.

4. Do not allow the temperature of water in the boiler to exceed 200°F ($\pm 12^\circ$). If it does, the heater will automatically shut off.

5. Water may be discharged through the gun assemblies or through the shower by opening either VALVES NO. 2 or 3 (location illustrated) while water is being heated. Also when the heater is in operation, fresh water may be continuously added to the tank from a hydrant or hose. VALVE NO. 1 can control the temperature of water by metering the water flow through the heater. Do not allow the pump pressure to fall below 60 psi.

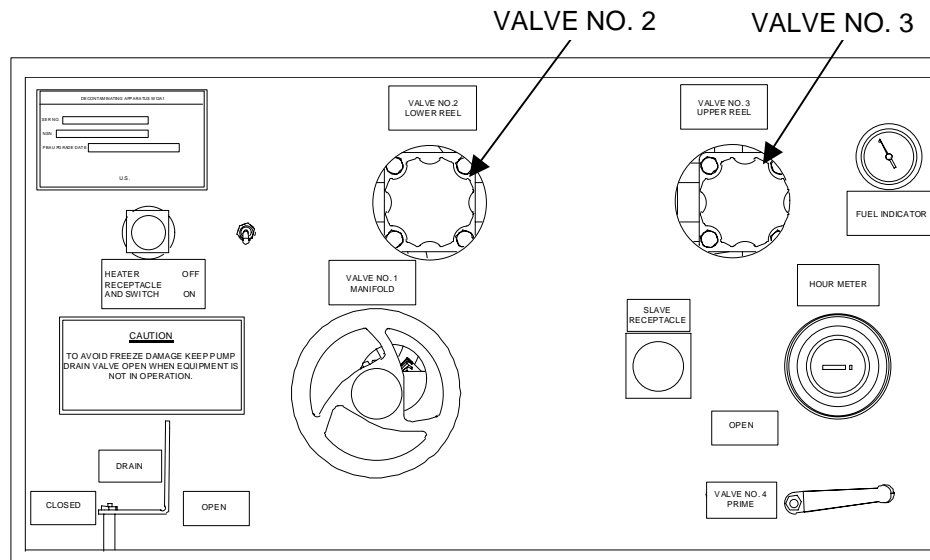

STOPPING THE WATER HEATER

1. When the required amount of water is heated to the desired temperature, stop the water heater by performing the following steps.
 - a. Turn the THERMOSTAT control knob OFF. After combustion ceases, operate for 2 minutes. Turn HEATER ON-OFF switch to OFF position.
 - b. Place HEATER RECEPTACLE AND SWITCH on pump unit to OFF.

NOTE

If you are heating water in tank unit for mixing chemicals other than STB, disregard temperature and time requirements.

- c. Continue to cycle water through the boiler for at least 3 minutes or until the water temperature is approximately 100° F as indicated on the WATER TEMPERATURE gage.

STOPPING THE WATER HEATER - Continued**CAUTION**

Insure that water heater is cool before storing the main electrical power cable and fuel hoses in the storage compartment.

- d. Disconnect the main electrical power cable (16). Cap HEATER RECEPTACLE AND SWITCH socket. Stow the main electrical power cable neatly in the storage compartment of the water heater.

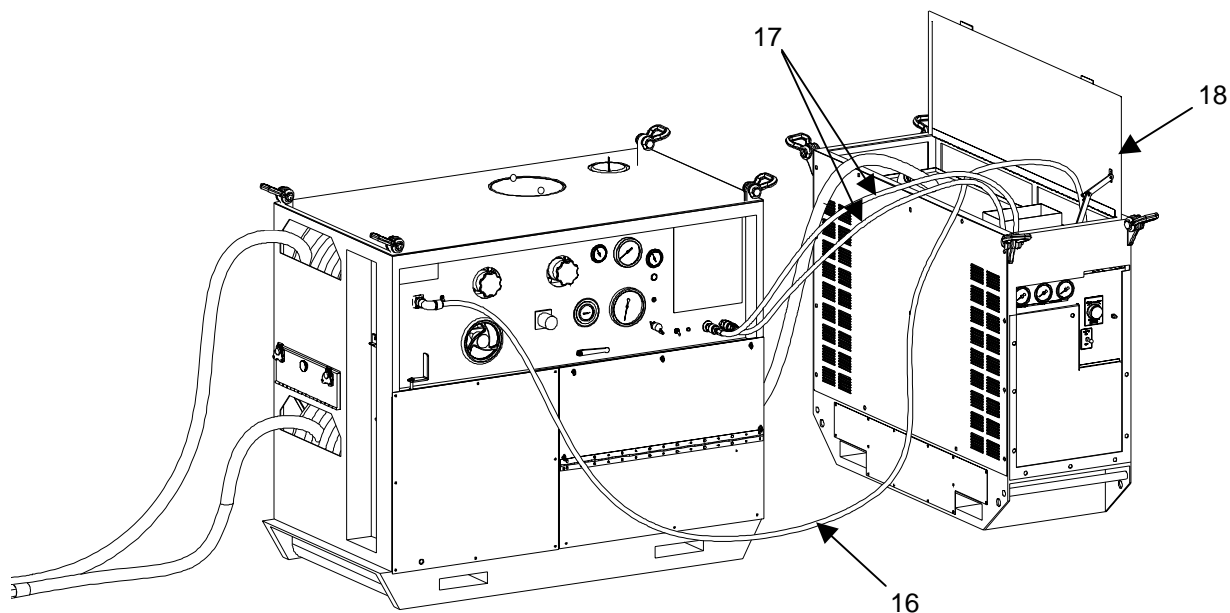
**CAUTION**

Let water heater cool before disconnecting fuel lines.

2. Stop the pump unit assembly by turning the IGNITION SWITCH to STOP and closing the fuel shutoff valve.
3. Disconnect the fuel supply and the fuel return hoses (17) from the pump unit. Reconnect the caps on the quick disconnect couplings for the fuel supply and fuel return lines.
4. Stow fuel hoses in top of water heater in storage compartment.
5. Close all valves opened for operation.

WARNING

When disconnecting the hoses with the water temperature above 100° F (38° C), exercise extreme care to prevent scalding.

6. Disconnect the blender hose from the heater base and make the appropriate connections for the next operation. For shutdown, coil water hose neatly in storage compartment. Allow the water heater to drain. It will drain completely through the water inlet.
7. Install protective cap on heater inlet.
8. Close and latch storage compartment door (18).

HEATING WATER DRAWN FROM A NATURAL SOURCE

| OPERATION NO | OPERATION | PREVIOUS OPERATION REQUIRED | OPERATION SOURCE | SUCTION HOSE TO TANK CONNECTION | | DISCHARGE CONNECTION | | VALVE POSITION | | | | REMARKS |
|--------------|----------------------|-----------------------------|------------------|---------------------------------|-------|----------------------|-------|----------------|----------|----------|----------|-----------------------------|
| | | | | UPPER | LOWER | UPPER | LOWER | VALVE #1 | VALVE #2 | VALVE #3 | VALVE #4 | |
| 7 | DISCHARGE UPPER REEL | 1 | S/T | ON | ON | X | X | O | X | | | *FROM HEATER **TO HEATER |
| | HOT WATER LOWER REEL | 1 | S/T | ON | ON | X | O | X | X | | | *FROM HEATER **TO HEATER |

NOTE

If the tank cannot be filled prior to heating water, water from a natural source can be heated by pumping it directly through the heater.

1. Follow operation number 7 on the STARTING PROCEDURE instruction plate.

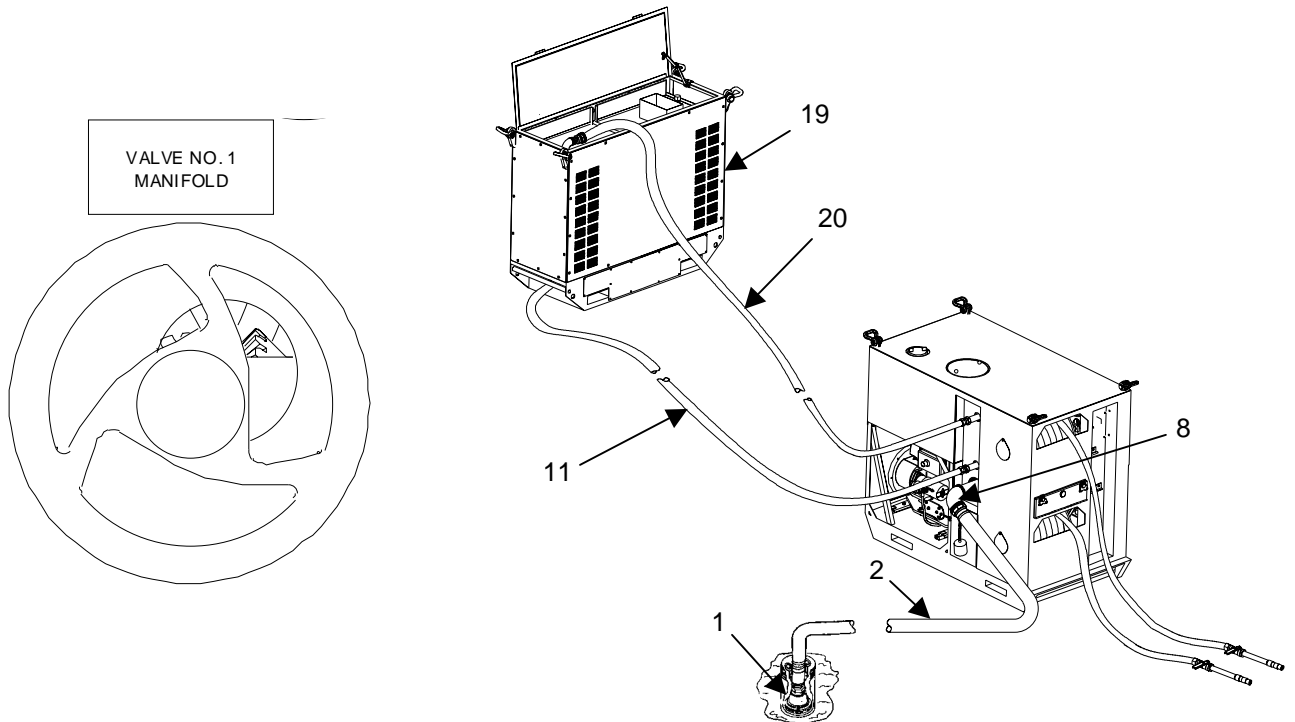

2. Make sure VALVE NO. 1 is closed.
3. Connect one end of suction hose (2) to the suction connection on the pump unit (8) and the other end to the foot valve assembly (1). When practical, place the foot valve in an empty STB decontaminating drum or equivalent and immerse the foot valve.
4. Connect one end of blender hose (11) to pump unit bottom discharge connection and other end to water heater (19) bottom connection.
5. Connect one end of heater unit water hose (20) to pump unit upper discharge piping, and the other end to water heater (19) upper connection.

HEATING WATER DRAWN FROM A NATURAL SOURCE - Continued

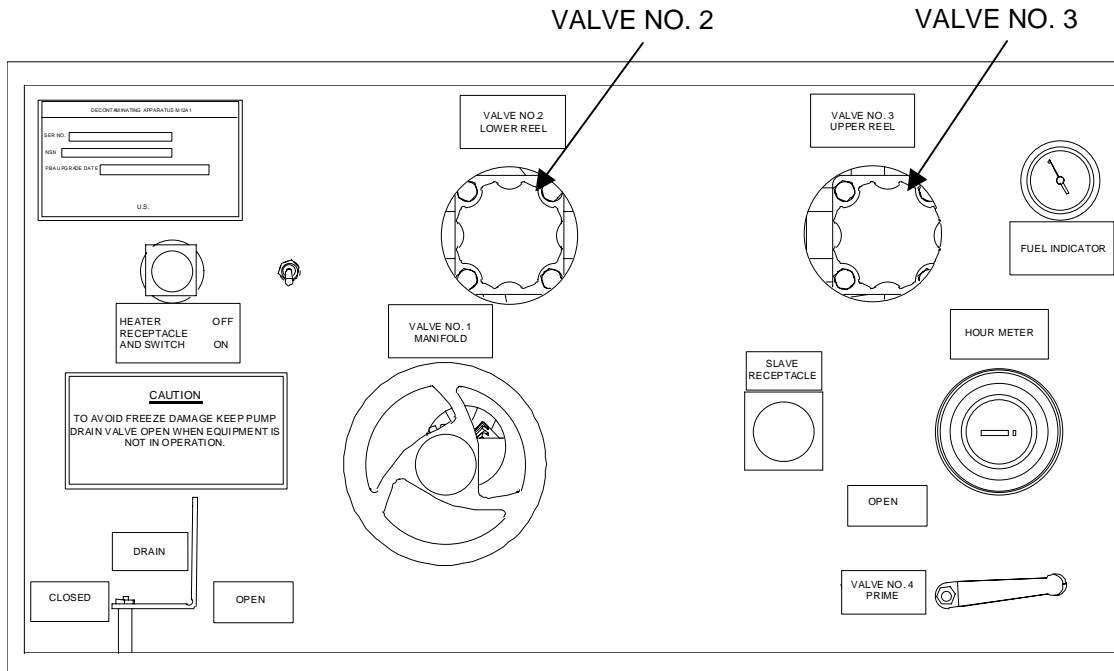

6. Make sure VALVE NOS. 2 and/or 3 are open. Hot water can be sprayed through the upper and/or lower reels and out discharge hose(s).
7. Prime and start the pump unit (Page 0006 00-1).
8. Start and run the water heater (Page 0007 00-7).
9. After mission is complete, stop the water heater (Page 0007 00-9).

HEATING WATER FROM THE TANK

| OPERATION NO. | | OPERATION | | VALVE POSITION O—OPEN X—CLOSED | | | | | | | | REMARKS |
|---------------|-----------|------------|---|-----------------------------------|------------------------|--------------------------|----------------------------|----------------------------|-------------------|---------------------|---------------------|-----------------------------|
| | | | | PREVIOUS OPERATION REQUIRED | SUCTION HOSE TO SOURCE | DISCHARGE HOSE TO T—TANK | DISCHARGE CONNECTION UPPER | DISCHARGE CONNECTION LOWER | VALVE #1 MANIFOLD | VALVE #2 LOWER REEL | VALVE #3 UPPER REEL | |
| 7 | DISCHARGE | UPPER REEL | 1 | S/T | ON | ON | X | X | O | X | | *FROM HEATER **TO HEATER |
| | HOT WATER | LOWER REEL | 1 | S/T | ON | ON | X | O | X | X | | *FROM HEATER **TO HEATER |

1. Follow operation number 7 on the STARTING PROCEDURE instruction plate.

HEATING WATER FROM THE TANK - Continued

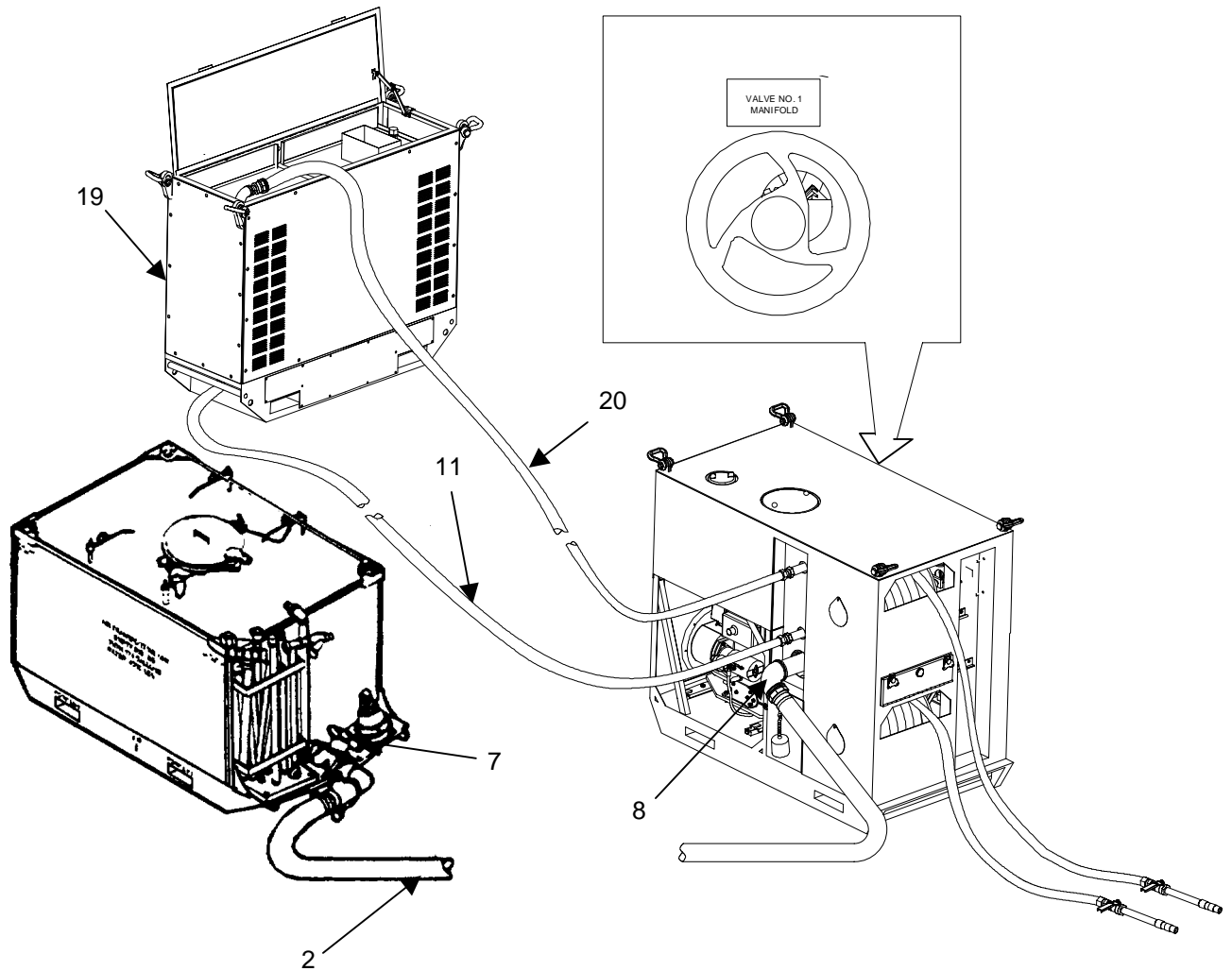

2. Make sure VALVE NO. 1 on the pump unit is closed.
3. Connect one end of suction hose (2) to tank unit drain valve (7) and other end to suction connection on pump unit (8). Open tank drain valve (7).
4. Connect one end of blender hose (11) to bottom discharge connection on pump unit and other end to bottom connection on water heater (19).
5. Connect free end of heater unit water hose (20) to upper discharge piping on pump unit and other end to upper connection on water heater.

HEATING WATER FROM THE TANK - Continued

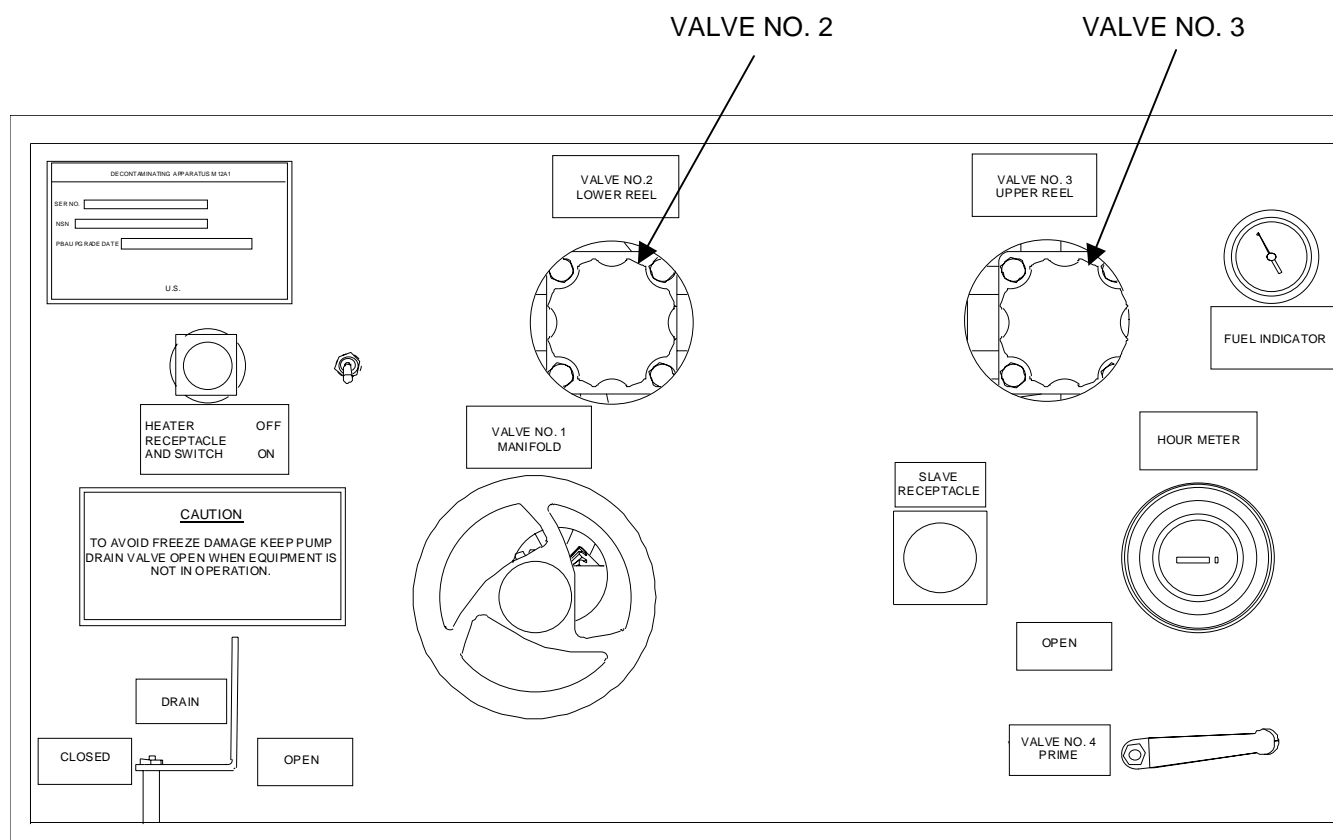

6. Make sure VALVES NO. 2 and/or 3 are open. Hot water can be sprayed through the upper and/or lower reels and out discharge hose(s).
7. Prime and start the pump unit (Page 0006 00-1).
8. Start and run the water heater (Page 0007 00-1).
9. After mission is complete, stop the water heater (Page 0007 00-9).
10. Stop the pump unit (Page 0006 00-7).
11. Clean and store the apparatus according to the applicable procedure listed in WP 0011 00.

END OF WORK PACKAGE

OPERATOR
M12A1 DIESEL ENGINE DRIVEN DECONTAMINATION APPARATUS
NSN 4230-01-502-7224
OPERATION UNDER USUAL CONDITIONS:
SPRAYING DECONTAMINANT SOLUTION

INITIAL SETUP:**Materials/Parts**

Silicone antifoam agent (Page 0028 00-1, item 1)
M2 antiset (Page 0028 00-1, item 2)
Calcium hypochlorite (Page 0028 00-2, item 6)
STB decontaminating agent (Page 0028 00-2, item 8)
Liquid detergent (Page 0028 00-2, item 9)
Fire extinguishing foam liquid (Page 0028 00-2, item 13)
Sodium carbonate (Page 0028 00-3, item 23)
Sodium hydroxide (Page 0028 00-3, item 24)

References

FM 3-11.5
TM 10-8415-209-10
WP 0006 00
WP 0007 00
WP 0011 00

WARNING

Wear protective clothing and a mask when engaged in decontaminating operations. STB decontaminating agent and slurry are harmful to the skin, eyes, lungs, and clothing. If STB decontaminating agent or slurry gets into the eyes, flush them immediately with clear water. If STB decontaminating agent or slurry is taken internally, drink raw egg white, milk, rice gruel, or milk of magnesia. Do not induce vomiting. Seek medical assistance immediately. If STB decontaminating agent or slurry contacts the skin, wash off immediately with clear water.

Do not use antifreeze with STB. Heat releasing reaction occurs.

MAKING STB DECONTAMINATING AGENT SLURRY**General**

When preparing slurry, add the M2 antiset (Page 0028 00-1, item 2) to the water first. Mix water with M2 antiset for 3 minutes. Next add the silicone antifoam agent (Page 0028 00-1, item 1). Mix silicone antifoam agent for at least 3 minutes before adding the STB decontaminating agent (Page 0028 00-2, item 8). Prepare the slurry as near to using time as possible. Never prepare slurry more than 4 hours in advance of use. STB will dissolve more rapidly in hot water.

M2 Antiset

M2
ANTISET
12 1/2 LB
DRUM

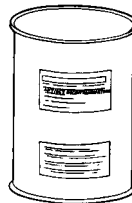

The M2 antiset (Page 0028 00-1, item 2) retards setting of the slurry. If M2 antiset is not added, especially in cold weather, the slurry will set rapidly and will form a hard mortar-like mass that will clog the tank and lines. Add M2 antiset in the proportion of 1 pound to each 100 pounds of STB agent for small quantities of slurry or one 12-1/2 pound package of M2 antiset per 1,300 pounds of STB decontaminating agent (225 gallons of water). Remove the hopper tank lid and load the M2 antiset into the tank through the hopper-blender.

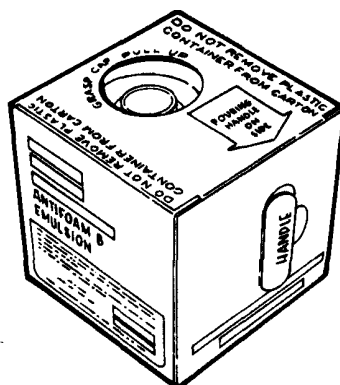
MAKING STB DECONTAMINATING AGENT SLURRY - Continued**Silicone Antifoam Agent****SILICONE ANTIFOAM AGENT**

Add approximately 24 ounces of silicone antifoam agent (Page 0028 00-1, item 1) to the mixture to prevent foaming of the slurry for a filling of the tank (225 gallons). Adding silicone antifoam agent to the mixture does not affect the decontaminating properties of the STB decontaminating agent.

STB Decontaminating Agent**WARNING**

Use caution when opening drums of Super Tropical Bleach (STB). Avoid contact with skin or eyes. Avoid contamination with acids and oxidizable materials such as fuels, oils, paint products, disinfectants, and ammonia. Such contamination can cause release of hazardous gases. Keep container closed and stored in a cool dry place. Mix only in accordance with directions for use. In case of contact with skin or eyes, immediately flush continuously with water; for eyes get medical attention.

**STB DECONTAMINATING AGENT**

The most effective mixture of water and STB decontaminating agent is prepared by mixing 40 parts (by weight) of STB decontaminating agent (Page 0028 00-2, item 8) with 60 parts (by weight) of water (8.3 lb per gallon). The decontaminating apparatus accommodates a mixture of 1,300 pounds of STB with 225 gallons of water. This mixture provides approximately 317 gallons of slurry which weighs about 10 pounds per gallon.

NOTE

If less than 317 gallons of slurry are required, decrease all ingredients proportionately. That is, if one-half (158 gallons) of slurry mix is to be prepared, use approximately 115 gallons of water, 650 pounds of STB decontaminating agent, 6-1/2 pounds of antiset compound, and 12 ounces of silicone antifoam agent.

MAKING STB DECONTAMINATING AGENT SLURRY - Continued

Coverage of Slurry

Table 1 gives normal coverage of slurry for different types of surfaces.

Table 1. Coverage of Slurry.

| Type of Surface | Coverage | |
|---|--------------|---------------|
| | (Per gallon) | (Per filling) |
| Concrete road (smooth) | 4.4 sq yd | 350 sq yd |
| Macadam or gravel road (loosely surfaced) | 2.2 sq yd | 675 sq yd |
| Short grass (3 to 5 in.) | 1.5 sq yd | 464 sq yd |
| Long grass and low brush | 1 sq yd | 310 sq yd |

FM 3-11.5 gives additional decontaminating information.

Adding and Blending M2 Antiset and Silicone Antifoam Agent

| OPERATION NO | OPERATION | PREVIOUS OPERATION REQUIRED | SUCTION HOSE TO DISCHARGE | TANK CONNECTION LOWER | VALVE #1 MAINFOLD LOWER | VALVE #2 LOWER REEL UPPER | VALVE #3 UPPER REEL | VALVE #4 PRIME DECONT | VALVE POSITION | | REMARKS |
|--------------|--------------|-----------------------------|---------------------------|-----------------------|-------------------------|---------------------------|---------------------|-----------------------|----------------|------------|---|
| | | | | | | | | | O - OPEN | X - CLOSED | |
| 3 | BLEND SLURRY | 2 | T | ON | CAP | O | X | X | X | | *TO TANK BLENDER ADD ANTISET THEN ADD STB |

1. Follow operation number 3 on the STARTING PROCEDURE instruction plate.

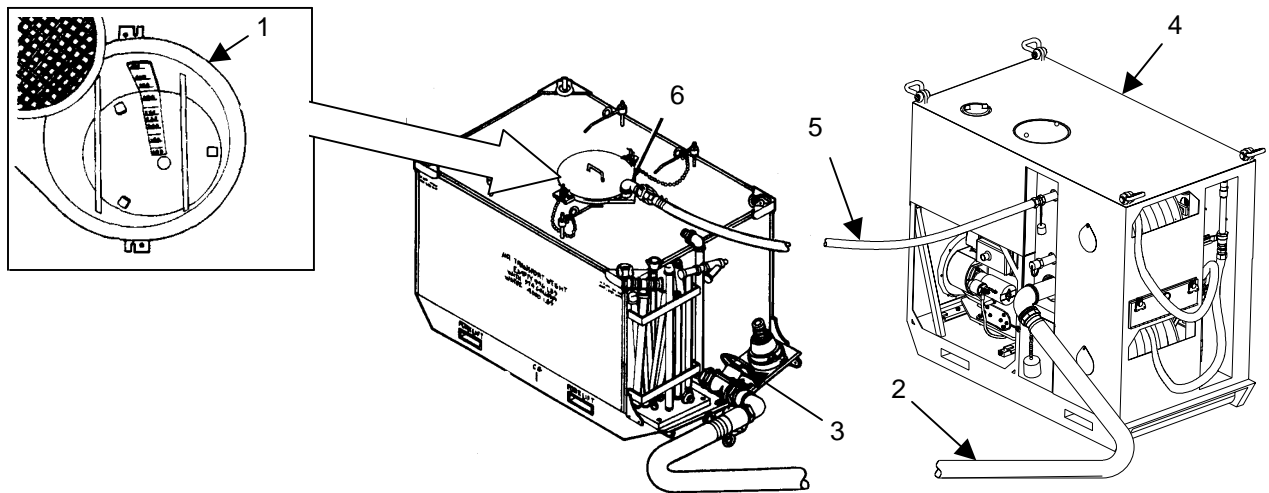

2. Fill the tank with the desired amount of water (Page 0007 00-4 or -5). Check tank liquid level indicator (1).
3. Connect the suction hose (2) to the tank drain valve (3) and the connection on the pump unit (4) as illustrated.
4. Connect agitator-blender hose (5) to pump unit (4) top discharge connection and to tank unit blender pipe (6).
5. Be sure that bolts holding hopper-blender are in place and tightened.

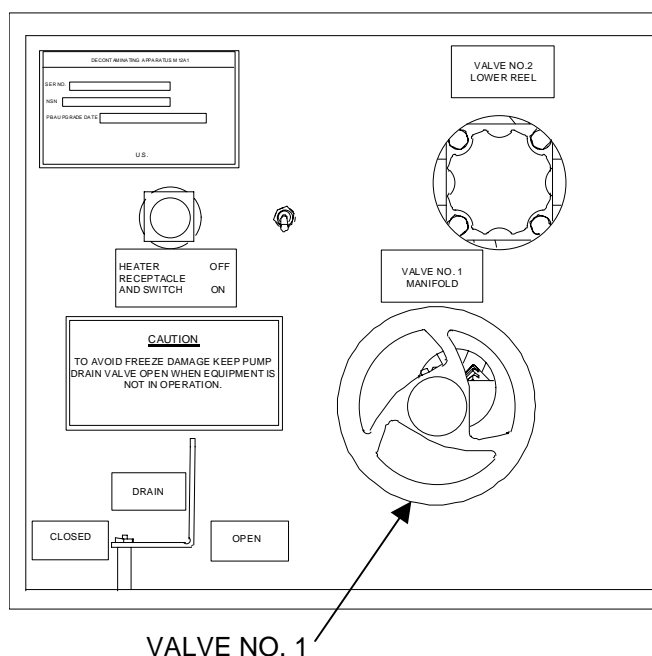
MAKING STB DECONTAMINATING AGENT SLURRY - Continued**Adding and Blending M2 Antiset and Silicone Antifoam Agent - Continued**

6. Start the pump unit (Page 0006 00-1). Open VALVE NO. 1 for this operation. Remove the hopper tank lid.

CAUTION

Cycle water containing M2 antiset for at least 3 minutes. The M2 antiset must be completely dissolved.

NOTE

If the M2 antiset is caked, it must be crushed as finely as possible before adding it to the water in the tank unit assembly.

7. Add the M2 antiset and silicone antifoam agent. Operate for 3 minutes to fully blend these additives.
8. To prepare STB decontaminating agent for loading, open the 26 cans of STB decontaminating agent (Page 0028 00-2, item 8).

NOTE

Before starting the loading and blending operations, break up the large lumps of STB to prevent clogging of the lines and to ensure the best possible water-slurry mixture. To prevent damage to the equipment, do not strike the metal drums containing the STB decontaminating agent against the tank or any other part of the tank unit.

9. Add the 1,300 pounds of STB decontaminating agent (Page 0028 00-2, item 8) in one continuous operation. When loading agent, see that hopper does not run out of STB decontaminating agent. If the supply of agent is exhausted before loading is completed, the slurry in the tank may foam. Stop foaming by adding additional silicone antifoam agent.

CAUTION

After the slurry is blended, it must be agitated constantly until used.

10. After blending is complete, replace tank lid. Agitate the slurry mixture.

MAKING STB DECONTAMINATING AGENT SLURRY - Continued

Agitating Slurry in Tank Unit

| | | VALVE POSITION O - OPEN X - CLOSED | | | | | | | | REMARKS | |
|--------------|----------------|---------------------------------------|------------------------|------------------------|----------------------------|----------------------------|-------------------|---------------------|---------------------|---------|------------------------|
| OPERATION NO | OPERATION | PREVIOUS OPERATION REQUIRED | SUCTION HOSE TO SOURCE | DISCHARGE HOSE TO TANK | DISCHARGE CONNECTION UPPER | DISCHARGE CONNECTION LOWER | VALVE #1 MANIFOLD | VALVE #2 LOWER REEL | VALVE #3 UPPER REEL | | VALVE #4 PRIME DEAGENT |
| 4 | AGITATE SLURRY | J | T | ON | CAP | O | X | X | X | X | *TO TANK AGITATOR |

1. Follow operation No. 4 of the STARTING PROCEDURE instruction plate.

CAUTION

To ensure that VALVE NO. 1 is completely closed, check to see if slurry has flooded back into the tank unit as indicated on the tank liquid level indicator.

2. With the pump unit still operating, close VALVE NO. 1.

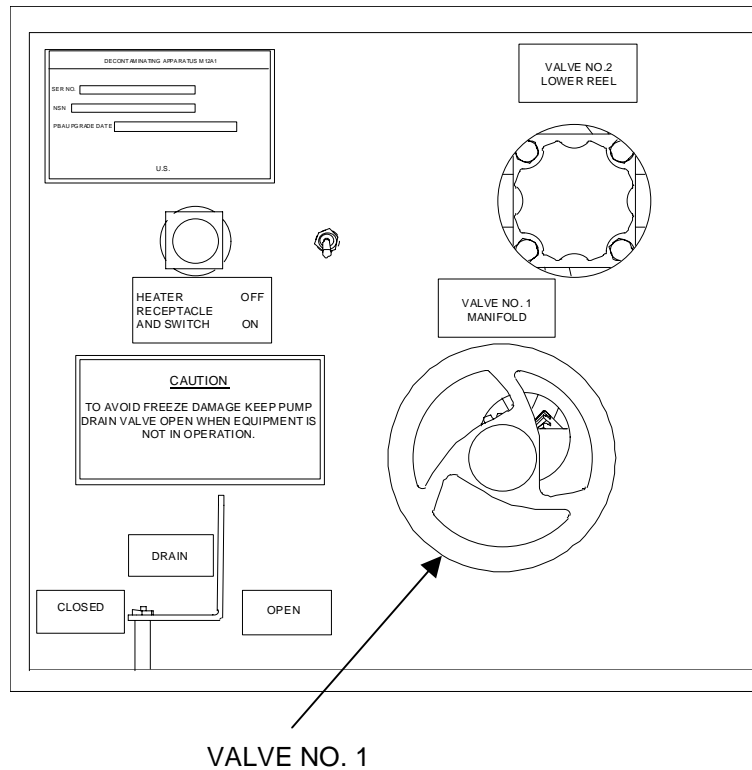

MAKING STB DECONTAMINATING AGENT SLURRY - Continued

Agitating Slurry in Tank Unit - Continued

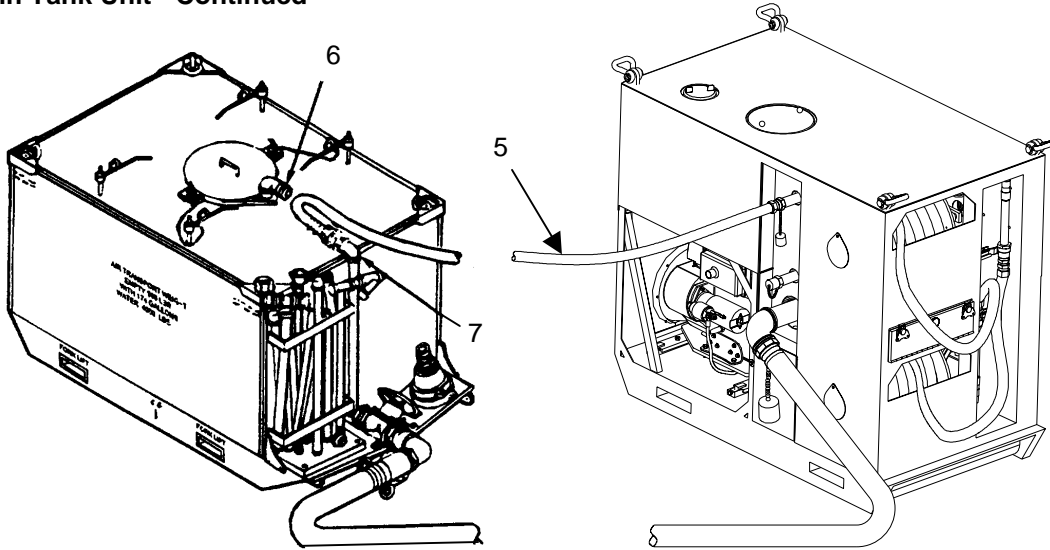

3. Disconnect the agitator-blender hose (5) from the blender pipe (6) on the tank unit and connect the hose to the agitator pipe (7).

4. Open VALVE NO. 1. Agitate for a minimum of 15 minutes, operating engine at preset speed. The pump discharge pressure gage should indicate approximately 105 psi. Continue agitating slurry until it is used.

Spraying Slurry From Tank

| OPERATION NO | | OPERATION | PREVIOUS OPERATION REQUIRED | S - SUCTON HOSE TO SOURCE | | D - DISCHARGE CONNECTION | | V - VALVE POSITION | | REMARKS | |
|--------------|-----------|------------|-----------------------------|---------------------------|-------|--------------------------|-------|--------------------|---|---------|---|
| | | | | UPPER | LOWER | UPPER | LOWER | 1 | 2 | | 3 |
| 5 | DISCHARGE | UPPER REEL | 2, 3 | Y | CAP | CAP | O | X | O | X | |
| | SLURRY | LOWER REEL | 2, 3 | Y | CAP | CAP | O | O | X | X | |

1. Follow operation No. 5 of the STARTING PROCEDURE instruction plate.

MAKING STB DECONTAMINATING AGENT SLURRY - Continued

Spraying Slurry From Tank - Continued

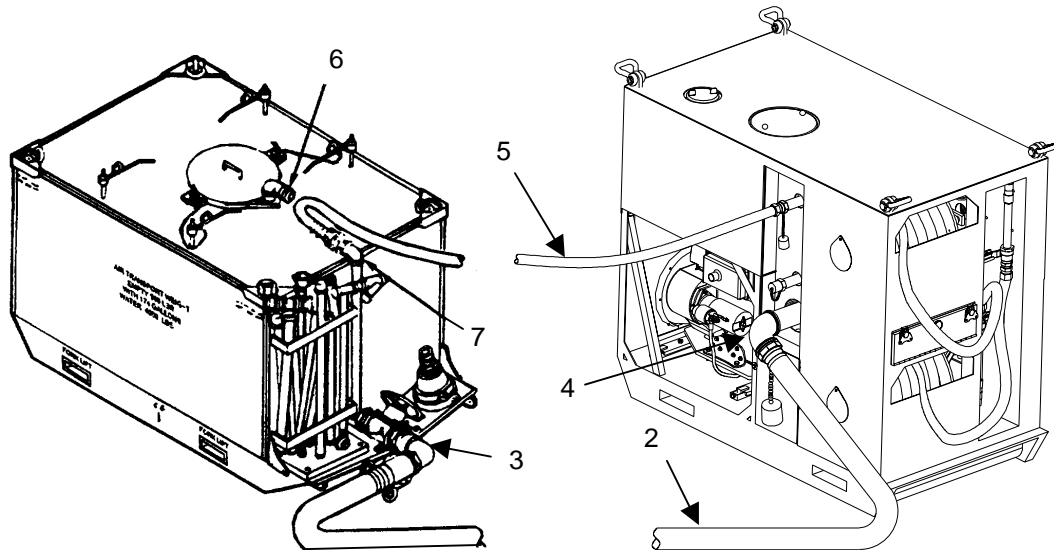

2. Make sure one end of suction hose (2) is connected to the pump unit (4) and the other end is connected to the tank drain valve (3) if not already connected.

CAUTION

To ensure that VALVE NO. 1 is completely closed, check to see that the slurry has flooded back into the tank unit as indicated by the tank liquid level indicator (approximately 317 gallons).

3. Close VALVE NO. 1 with the pump unit still operating.

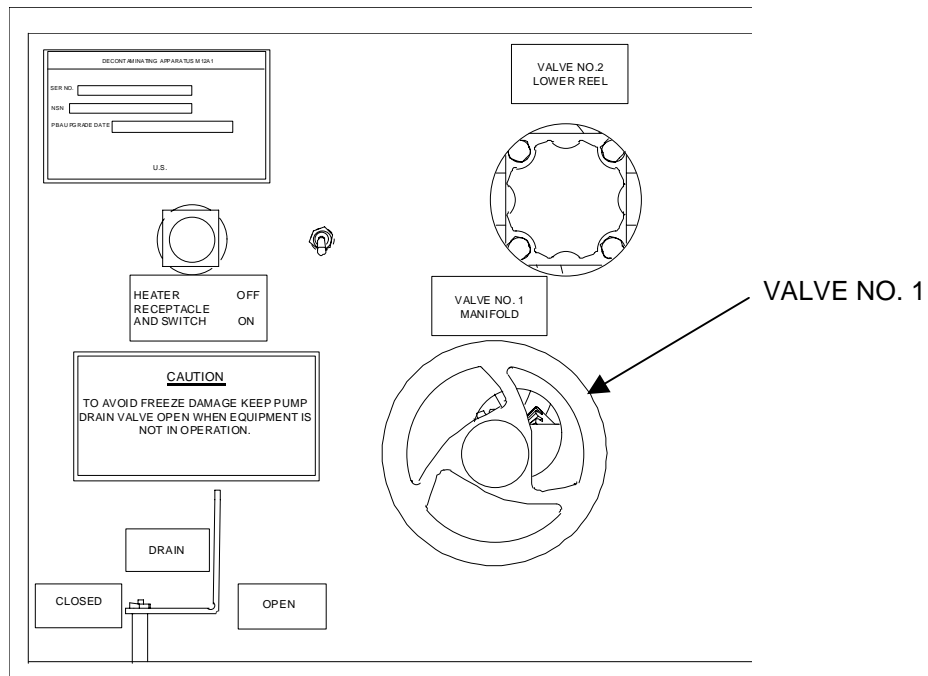

MAKING STB DECONTAMINATING AGENT SLURRY - Continued**Spraying Slurry From Tank - Continued****CAUTION**

The agitator-blender hose will contain slurry. Clean this hose before storing it on the tank unit.

NOTE

If only one discharge hose is to be used for spraying slurry, agitation of the slurry in the tank may continue. Open VALVE NO. 3 to the upper discharge hose. If adequate pressure is maintained (105 psi), continue both agitation and discharge. If not, stop agitation.

4. Disconnect the agitator-blender hose (5) from the pump unit. Cap the upper discharge pipe and disconnect the hose from the agitator pipe (7) on the tank unit.

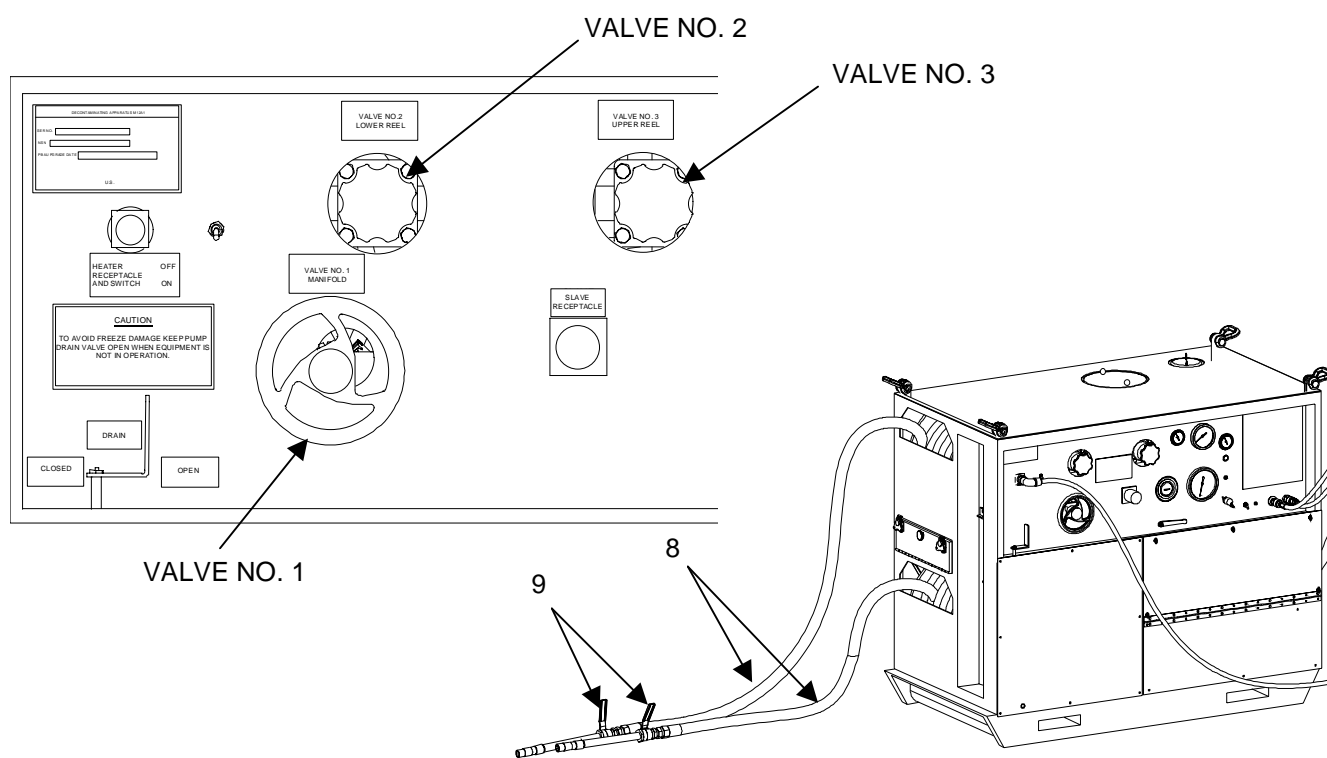

5. Unreel the discharge hoses (8).
6. Open VALVES NO. 1, 2, 3 and gun assembly valves (9).

NOTE

The PRESSURE GAGE indication while spraying slurry may vary between 60 and 120 psi.

7. Adjust the orifice and deflector assembly to vary the spray pattern from stream to fine spray mist. The pump discharge pressure gage should indicate approximately 105 psi pressure when slurry is being sprayed.
8. After the spraying mission is complete, flush, drain, clean, and store the apparatus according to procedure outlined in Work Package 0011 00.

MIXING CHEMICALS OTHER THAN STB IN TANK**CAUTION**

Never run anything other than clear water through the water heater. Always heat water to desired temperature before adding chemicals.

NOTE

Protective clothes and their use are contained in TM 10-8415-209-10.

Chemicals other than STB may be mixed in the tank. Below are the procedures for mixing four of those chemicals, sodium hydroxide (Page 0028 00-3, item 24), sodium carbonate (soda ash) (Page 0028 00-3, item 23), calcium hypochlorite (Page 0028 00-2, item 6), and sodium hypochlorite. In general, chemicals which are water soluble and in powdered or granular form must be mixed in the tank using the tank hopper-blender and blender connection. Refer to FM 3-11.5, *NBC Decontamination*, for additional information on decontaminants and decontaminating methods.

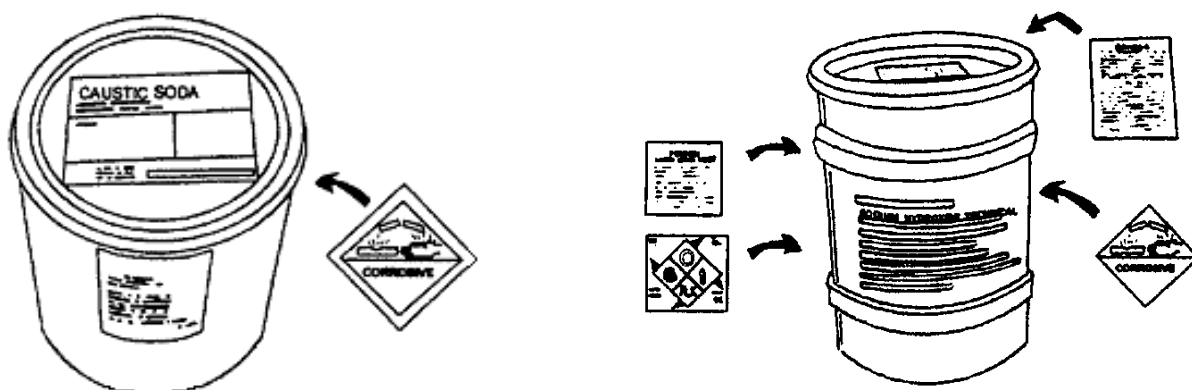
Sodium Hydroxide**WARNING**

When mixing, blending, or spraying sodium hydroxide solution, personnel must wear full rubber protective clothing, gloves, boots, and mask, as even a five percent solution will eat away woolen or cotton clothing. Avoid contact with the skin or eyes and avoid breathing the dust.

NOTE

Sodium hydroxide, commonly called caustic soda (or lye), dissolves easily in water. When dissolved in water, caustic soda generates a considerable amount of heat. A solution of water and caustic soda will destroy G-agents on contact.

For fast decontamination, spray heated rather than cold solutions of this decontaminant. The heat hastens the neutralizing actions of the decontaminating agent. Sodium hydroxide (Page 0028 00-3, item 24) is available in 100-pound drums.

1. Fill the tank unit assembly with 350 gallons of water. See Page 0007 00-12 for hose, fuel, and electrical connections for heating water in tank. Heat the water to a temperature of 150°-170°F. After heating the water, place heater THERMOSTAT to OFF. Continue circulating water for 2 minutes through the heater, then turn HEATER ON/OFF switch to OFF.

MIXING CHEMICALS OTHER THAN STB IN TANK - Continued

Sodium Hydroxide - Continued

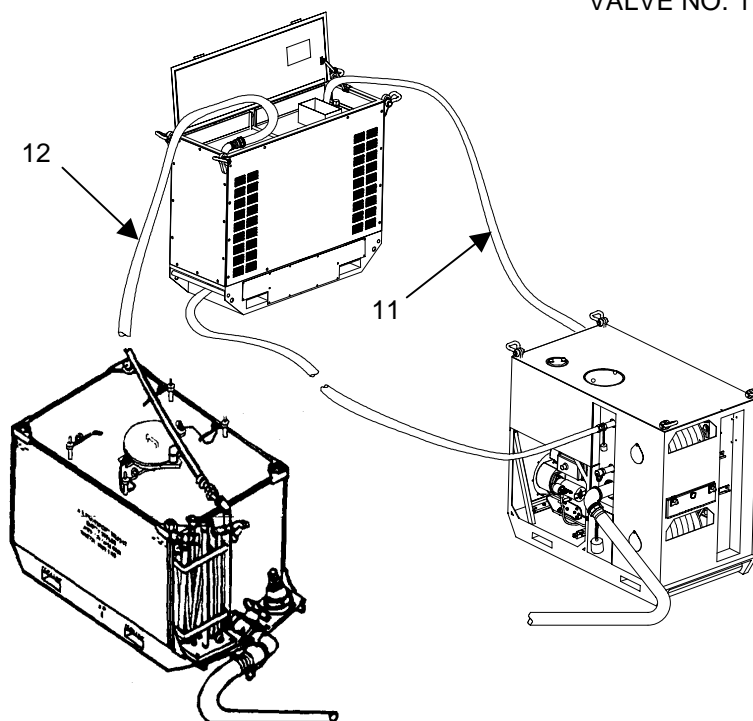
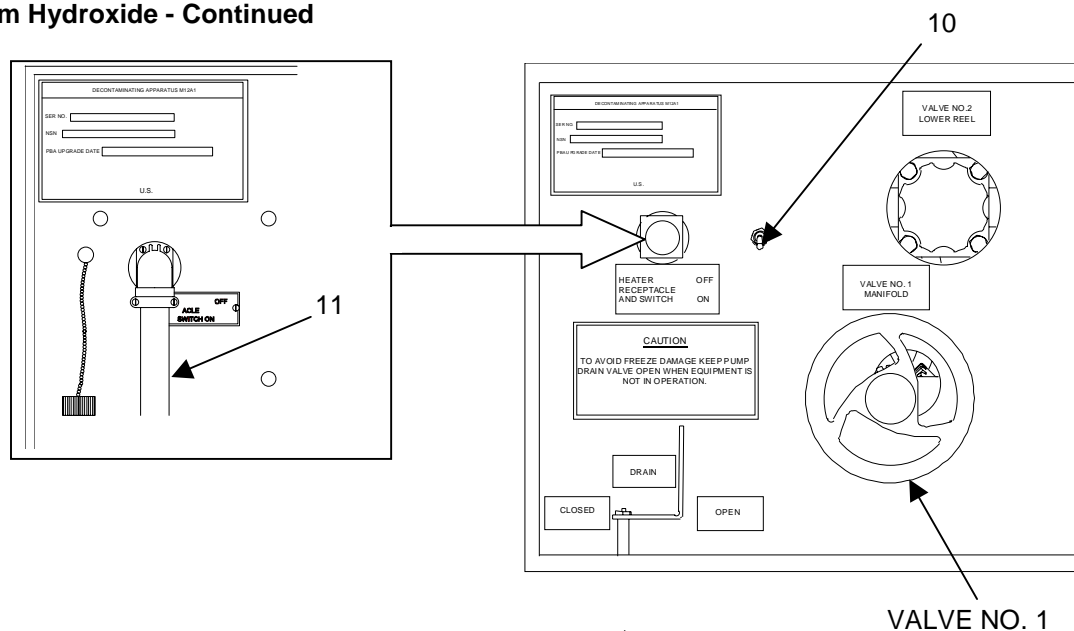

2. Place the HEATER RECEPTACLE AND SWITCH (10) on pump unit to OFF, disconnect the electrical power cable (11) and cap socket.

WARNING

When disconnecting the hoses with the water temperature at or above 100°F (38°C), exercise extreme care to prevent scalding.

3. Either shut down the pump unit or close VALVE NO. 1. Disconnect the water hose (12) from the tank unit agitator pipe.

MIXING CHEMICALS OTHER THAN STB IN TANK - Continued

Sodium Hydroxide - Continued

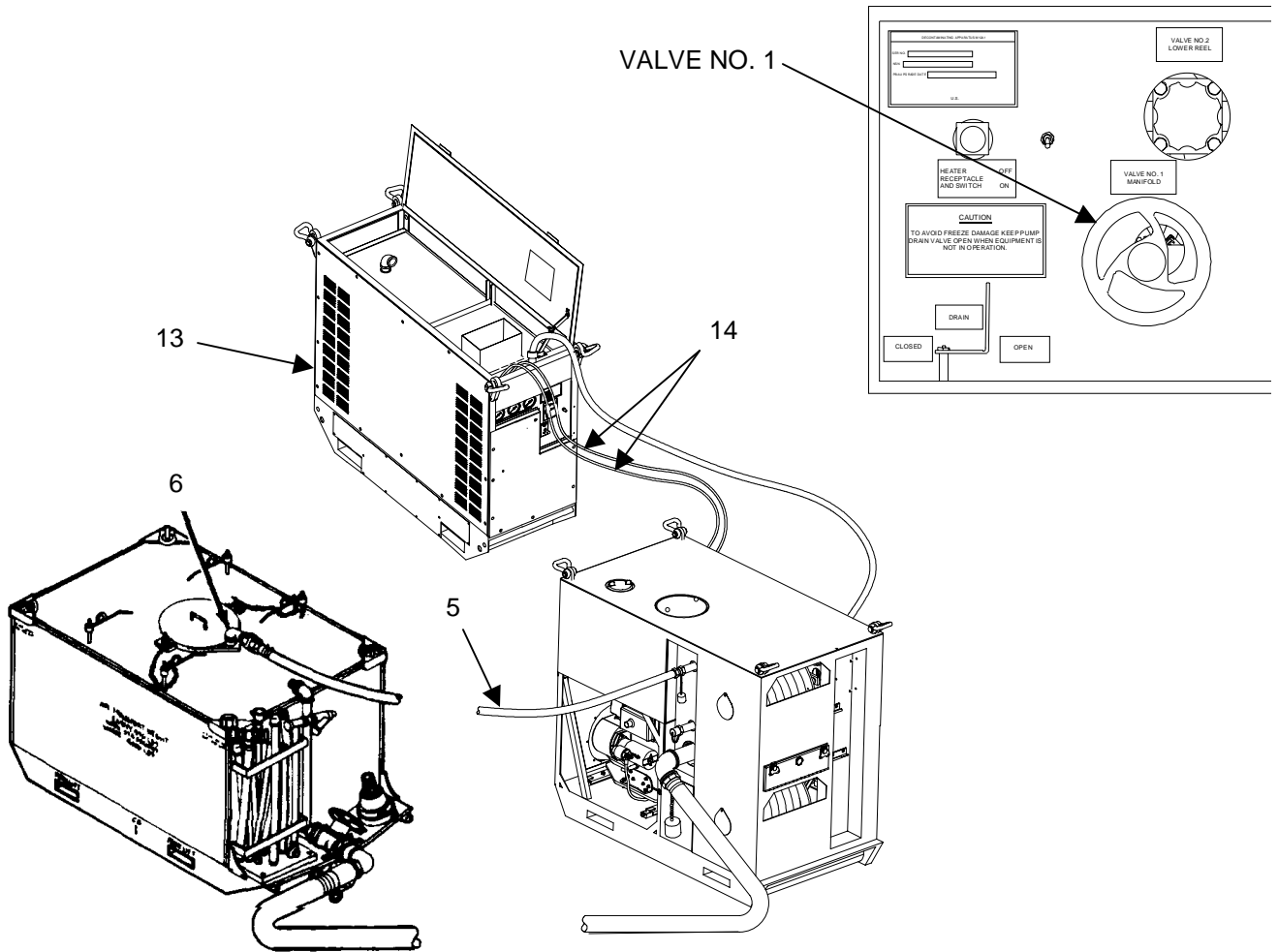

WARNING

When disconnecting the hoses with the water temperature at or above 100° F (38° C), exercise extreme care to prevent scalding.

CAUTION

Hot water is present in the heater and will drain when blender hose is disconnected.

4. Disconnect the blender hose (5) from water heater (13) bottom connection and connect it to the blender pipe (6) on the tank unit.

CAUTION

Insure that the water heater is cool before stowing the main electrical power cable and fuel and water hoses in the storage compartment.

5. Let the water heater cool before disconnecting the fuel hoses (14) from the water heater and the pump unit, then disconnect the fuel hoses (14) and stow the fuel line, water hose, and electrical cable in the water heater storage compartment. Cap fuel supply and return connections. Restart the pump or open VALVE NO. 1.

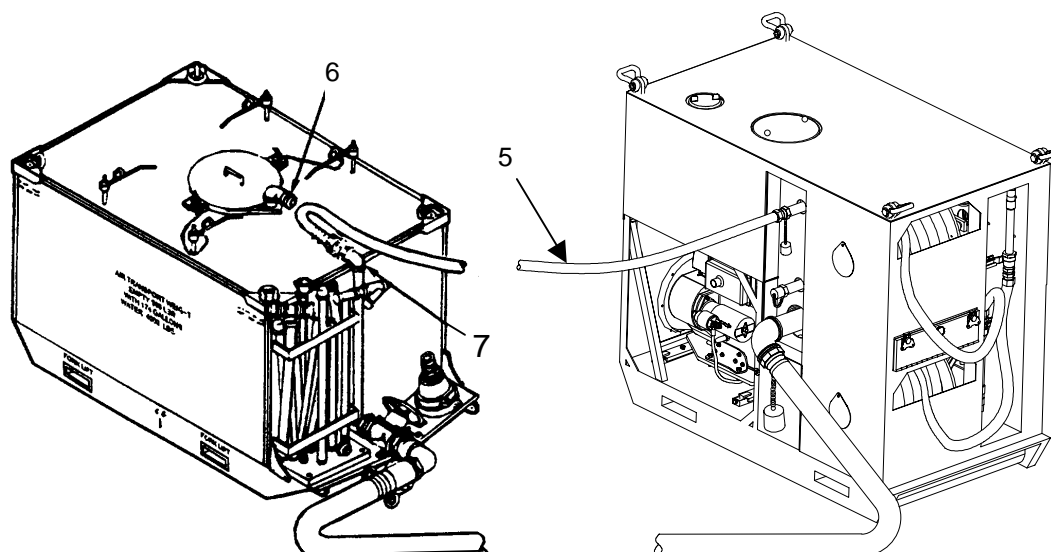
MIXING CHEMICALS OTHER THAN STB IN TANK - Continued**Sodium Hydroxide - Continued**

6. Blend 175 pounds (1-3/4 drums) of caustic soda to the 350 gallons of water (1/2 lb of sodium hydroxide to 1 gal. of water) through the hopper-blender. Keep the caustic soda moving through the hopper-blender by constant stirring. Blending will require 35 to 40 minutes.

NOTE

If mixture is not used immediately, agitate until used. It must be agitated (through the agitation connection) for 5 minutes before using.

7. If agitation is required, close VALVE NO. 1, disconnect the agitator-blender hose (5) from the blender pipe (6), and attach it to the agitator pipe (7) on the tank unit.

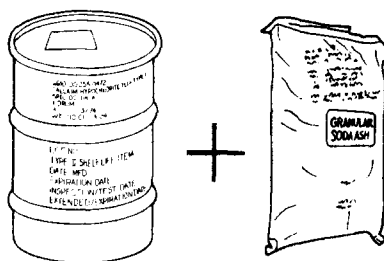
Sodium Hypochlorite

Sodium hypochlorite may be produced by mixing calcium hypochlorite (HTH) (Page 0028 00-2, item 6) and sodium carbonate (soda ash) (Page 0028 00-3, item 23) in the tank unit. The mixture produces sodium hypochlorite and a solid form of calcium carbonate. The particles of calcium carbonate must be kept in solution by agitation of the mixture.

MIXING CHEMICALS OTHER THAN STB IN TANK - Continued

Sodium Hypochlorite - Continued

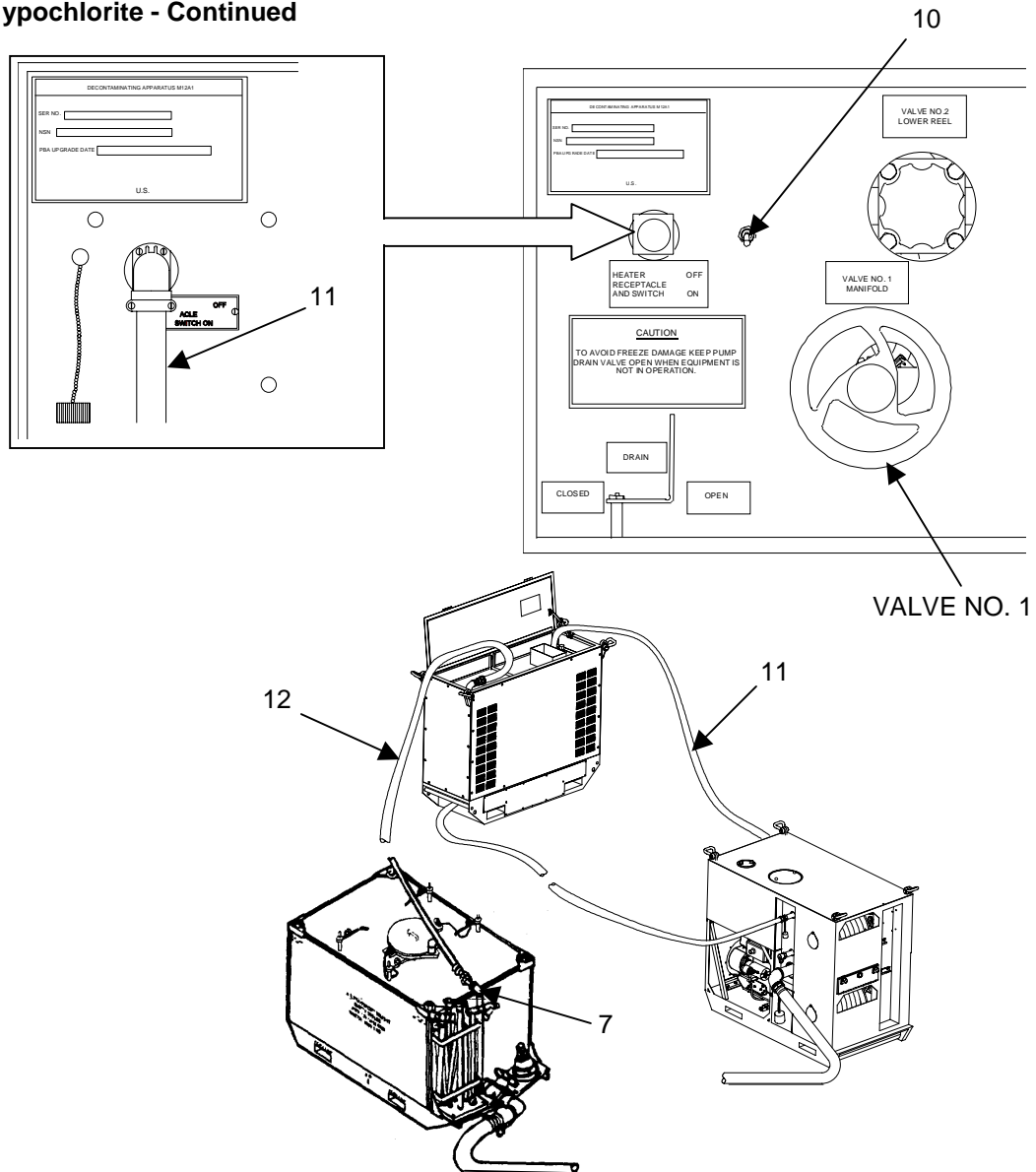

1. Fill the tank unit with 350 gallons of water. See Page 0007 00-12 for hose, fuel, and electrical connections for heating water in tank. Heat the water to an indicated temperature of 150°-175° F. After heating the water, place THERMOSTAT to OFF. Continue circulating water for 2 minutes through the heater, then turn HEATER ON/OFF switch to OFF.

2. Place the HEATER RECEPTACLE AND SWITCH (10) on pump unit to OFF and then disconnect the electrical power cable (11) and cap the socket.

WARNING

When disconnecting the hoses with the water temperature at or above 100° F (38° C), exercise extreme care to prevent scalding.

3. Either shut down the pump unit or close VALVE NO. 1. Disconnect the water hose (12) from the tank unit agitator pipe (7).

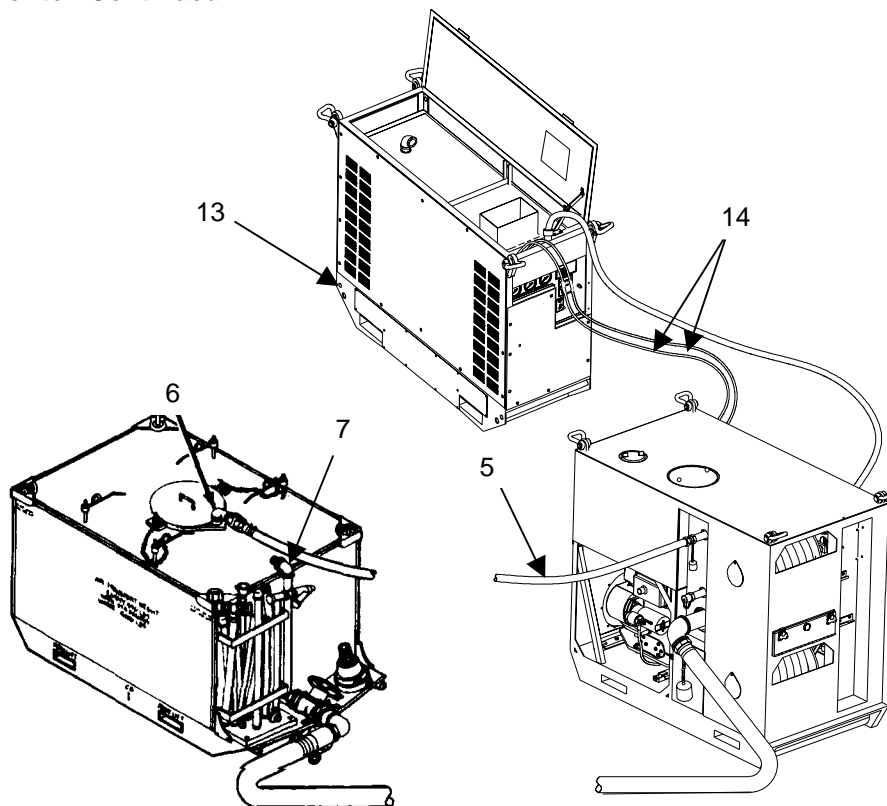
MIXING CHEMICALS OTHER THAN STB IN TANK - Continued**Sodium Hypochlorite - Continued****CAUTION**

Hot water is present in the heater and will drain when blender hose is disconnected.

4. Disconnect the blender hose (5) from the water heater (13) bottom connection and connect it to the blender pipe (6) on the tank unit.

CAUTION

Insure that the water heater is cool before stowing the main electrical power cable and fuel and water hoses in the storage compartment.

5. Let the water heater cool before disconnecting the fuel hoses (14) from the water heater and the pump unit, then disconnect the fuel hoses (14) and stow the fuel line, water hose, and electrical cable in the water heater storage compartment. Cap fuel supply and return connections. Restart the pump or open VALVE NO. 1.

6. Add 175 pounds of calcium hypochlorite (1/2 lb per 1 gal. of water) at a slow and steady rate. Add 250 pounds of sodium carbonate. It must be used immediately. If it is not, it must be agitated until used. Agitate for at least 3 minutes before using.

NOTE

If mixture is not used immediately, agitate until used. It must be agitated (through the agitation connection) for 5 minutes before using.

7. If agitation is required, close VALVE NO. 1, disconnect the agitator-blender hose (5) from the blender pipe (6), and attach it to the agitator pipe (7) on the tank unit.

MIXING CHEMICALS OTHER THAN STB IN TANK - Continued

Sodium Carbonate

NOTE

Sodium carbonate is commonly called soda ash, sal soda, washing soda, or laundry soda. The commercial grades may contain large amounts of sodium bicarbonate (baking soda). A sodium carbonate mixture does not neutralize blister agents or V-agents as readily as caustic soda or calcium hypochlorite. A hot or cold soda ash solution is effective on G-agents. Sodium carbonate is not as toxic as other decontaminants. However, crew members handling and preparing the solution should wear protective masks and gloves to guard against heavy clouds of powder.



Sodium carbonate (Page 0028 00-3, item 23) is available in 100 pound bags.

1. Fill the tank unit with 400 gallons of water. See Page 0007 00-12 for hose, fuel, and electrical connections for heating water in tank. Heat the water to an indicated temperature of 75°F. After heating the water, place THERMOSTAT to OFF. Continue circulating water for 2 minutes through the heater, then turn HEATER ON/OFF switch to OFF.

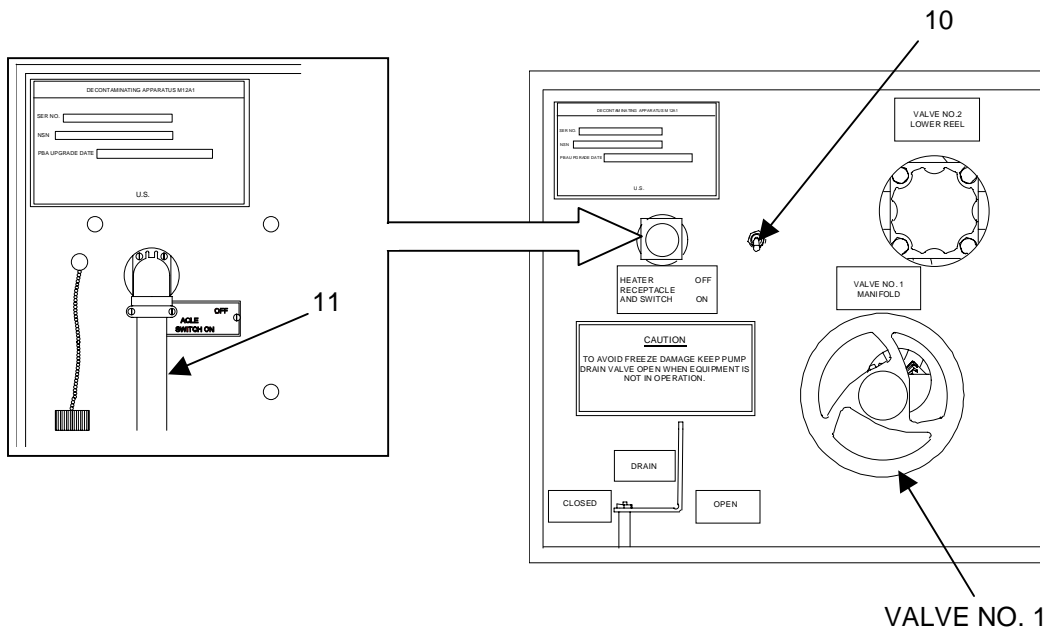

2. Place the HEATER RECEPTACLE AND SWITCH (10) on pump unit to OFF and then disconnect the electrical power cable (11) and cap the socket.

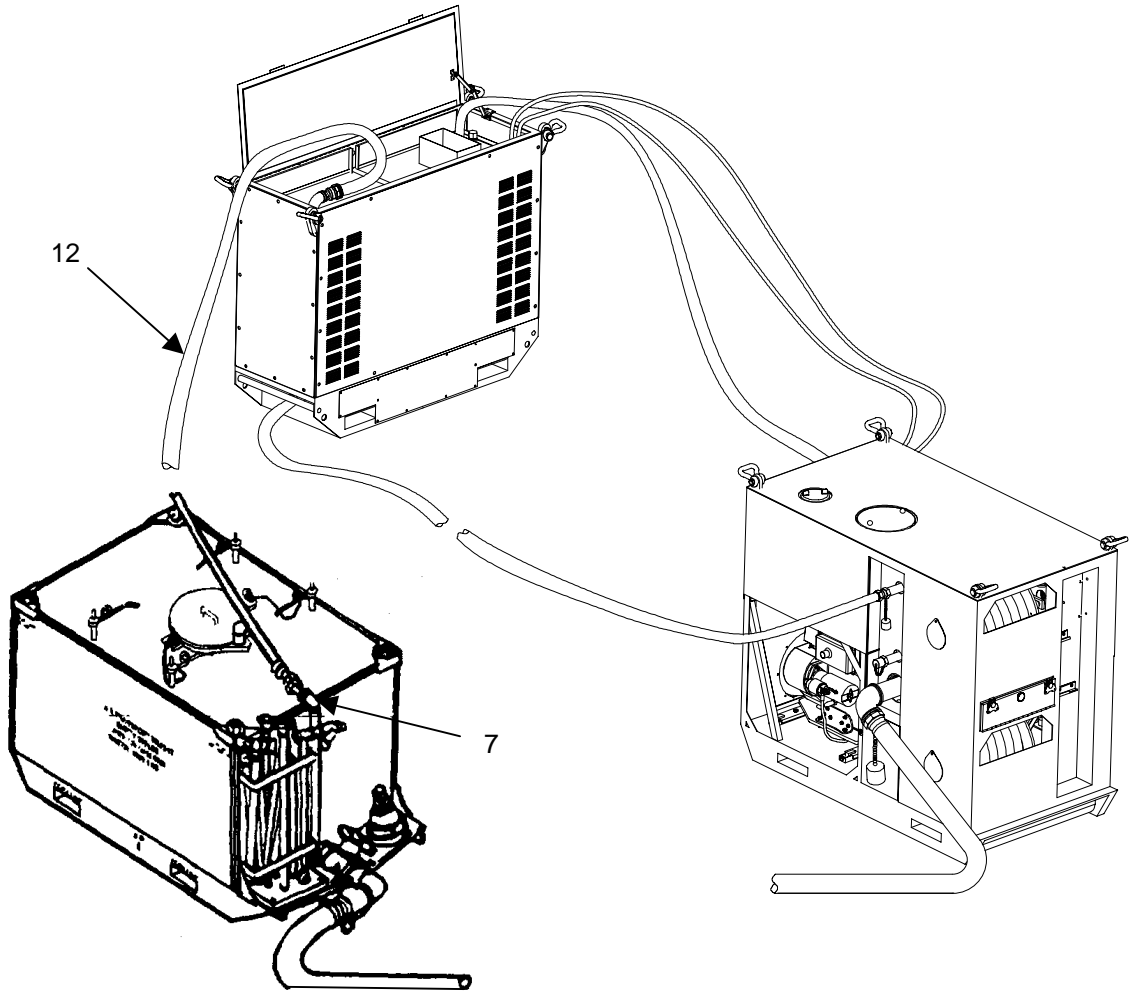
MIXING CHEMICALS OTHER THAN STB IN TANK - Continued**Sodium Carbonate - Continued****WARNING**

When disconnecting the hoses with the water temperature at or above 100° F (38° C), exercise extreme care to prevent scalding.

3. Either shut down the pump unit or close VALVE NO. 1. Disconnect the water hose (12) from the tank unit agitator pipe (7).

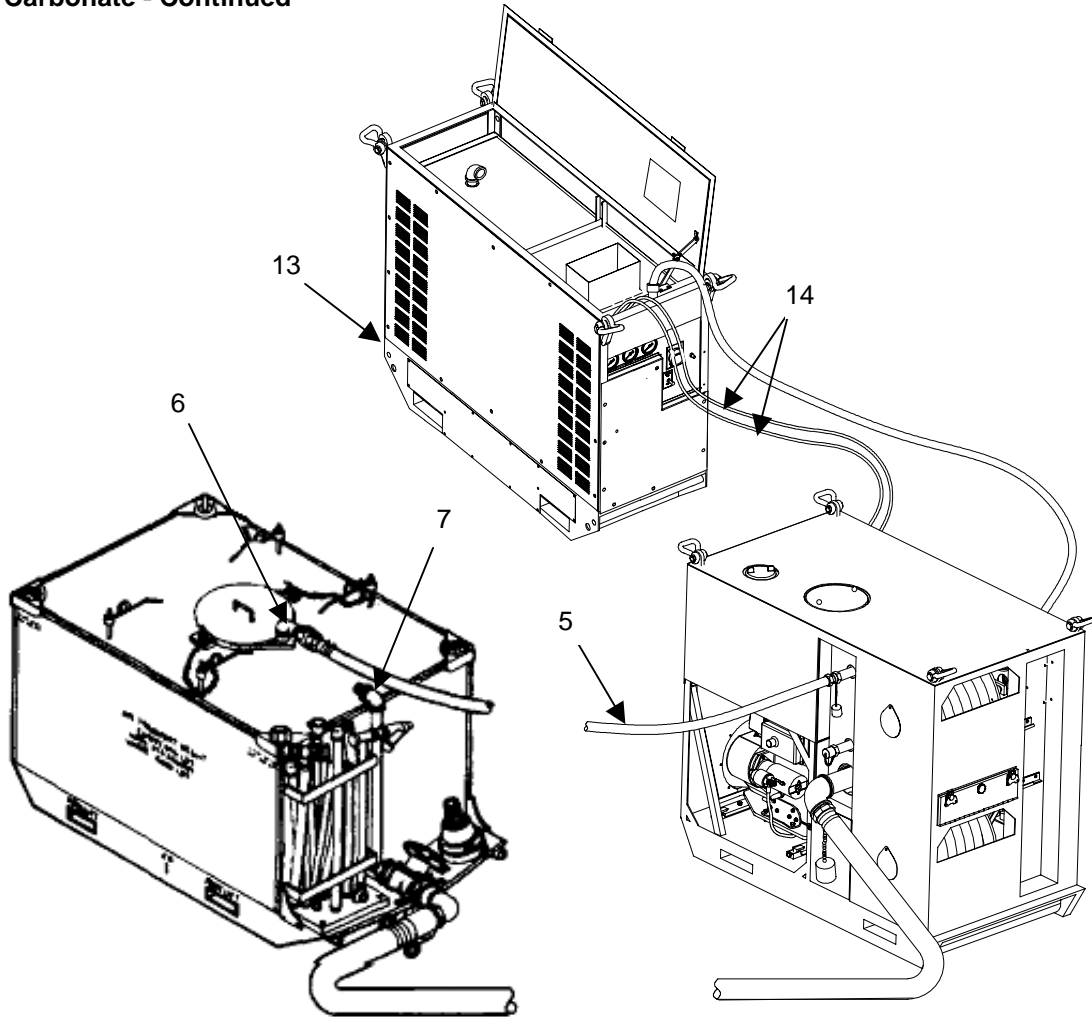
MIXING CHEMICALS OTHER THAN STB IN TANK - Continued**Sodium Carbonate - Continued****CAUTION**

Hot water is present in the heater and will drain when blender hose is disconnected.

4. Disconnect the blender hose (5) from the water heater (13) bottom connection and connect it to the blender pipe (6) on the tank unit.

CAUTION

Insure that the water heater is cool before stowing the main electrical power cable and fuel and water hoses in the storage compartment.

5. Disconnect the fuel hoses (14) from the water heater (13) and the pump unit. After the water heater has cooled, stow the fuel line, water hose and electrical cable in the water heater storage compartment. Cap fuel supply and return lines. Restart the pump unit or open VALVE NO. 1.

6. Blend 100 pounds of soda ash to the 400 gallons of water (1/4 lb of sodium carbonate per 1 gallon of water) through the blender connection at a slow but steady rate. If the mixture is not used immediately, it must be agitated until used. Agitate the mixture for at least 3 minutes before using.

7. If agitation is required, close VALVE NO. 1, disconnect the agitator-blender hose from the blender pipe (6) and attach it to the agitator pipe (7) on the tank unit.

MIXING CHEMICALS OTHER THAN STB IN TANK – Continued**Calcium Hypochlorite****WARNING**

Calcium hypochlorite will destroy clothing, has a toxic vapor, and will burn the skin.

CAUTION

Calcium hypochlorite (HTH) is highly corrosive. Its use with the decontaminating apparatus may shorten its useful life. HTH should not be used except in an emergency when STB is not available. Clean equipment thoroughly after it has been used to spray calcium hypochlorite; flush with large amounts of water. Protective gloves are to be worn when working with calcium hypochlorite.

Calcium hypochlorite (Page 0028 00-2, item 6) is available in both 25 pound and 100 pound drums.

1. Fill the tank unit with 350 gallons of water. See Page 0007 00-12 for hose, fuel, and electrical connections for heating water in tank. Heat water to an indicated temperature of 150°-175° F. After heating the water, place THERMOSTAT to OFF. Continue circulating water for 2 minutes through the heater, then turn HEATER ON/OFF switch to OFF.

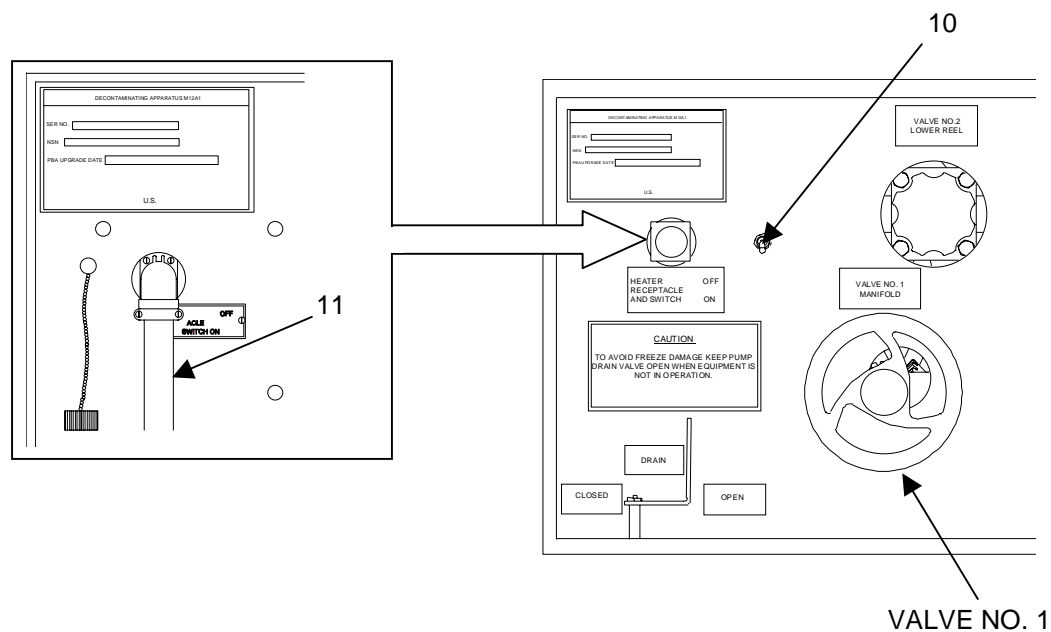

2. Place the HEATER RECEPTACLE AND SWITCH (10) on pump unit to OFF, disconnect the electrical power cable (11), and cap the socket.

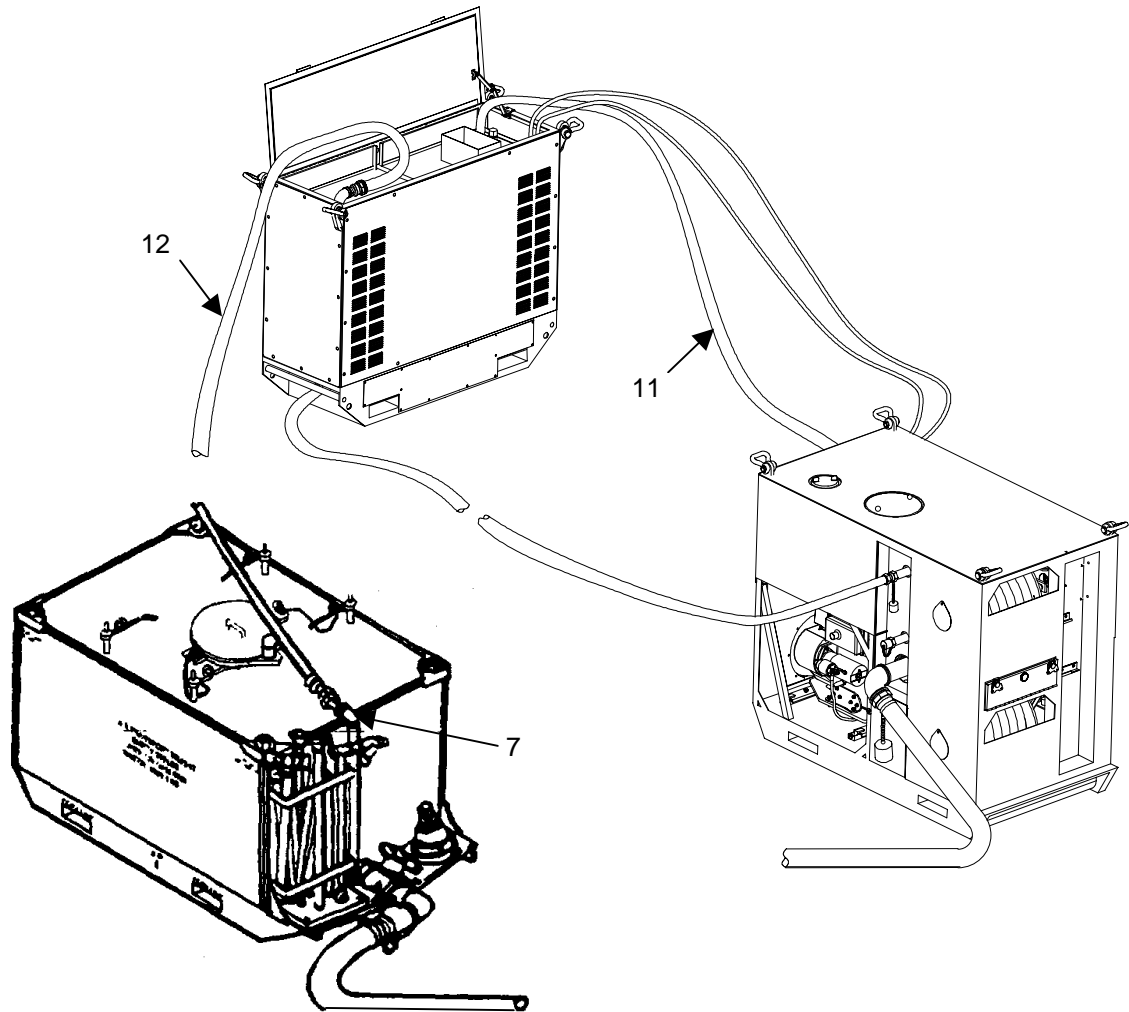
MIXING CHEMICALS OTHER THAN STB IN TANK - Continued**Calcium Hypochlorite - Continued****WARNING**

When disconnecting the hoses with the water temperature at or above 100° F (38° C), exercise extreme care to prevent scalding.

3. Either shut down the pump unit or close VALVE NO. 1. Disconnect the water hose (12) from the tank unit agitator pipe (7).

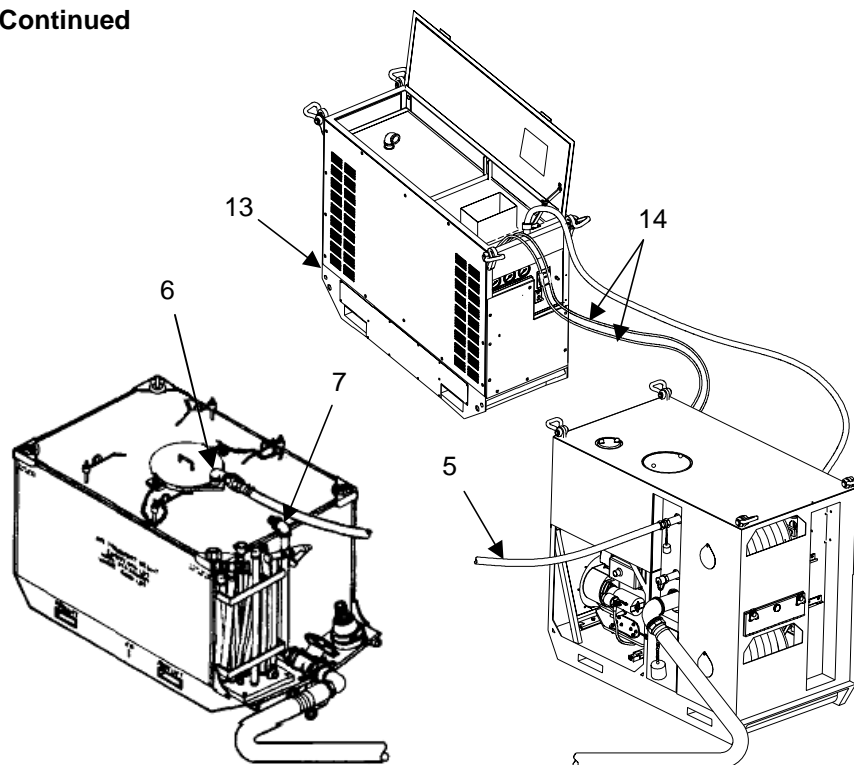
MIXING CHEMICALS OTHER THAN STB IN TANK - Continued**Calcium Hypochlorite - Continued****CAUTION**

Hot water is present in the heater and will drain when blender hose is disconnected.

4. Disconnect the blender hose (5) from the water heater (13) bottom connection and connect it to the blender pipe (6) on the tank unit.

CAUTION

Insure that the water heater is cool before stowing the main electrical power cable and fuel and water hoses in the storage compartment.

5. Disconnect the fuel hoses (14) from the water heater (13) and the pump unit (after the water heater has cooled) and stow in the water heater storage compartment. Cap fuel supply and return lines. Restart pump unit or open VALVE NO. 1.
6. Blend 175 pounds of calcium hypochlorite (1/2 lb to 1 gal. of water) to the 350 gallons of water through the blender pipe at a slow but steady rate. If the mixture is not used immediately, it must be stirred until used. Stir the mixture 3 minutes before using.
7. If agitation is required, close VALVE NO. 1, disconnect the agitator-blender hose (5) from the blender pipe (6) and attach it to the agitator-pipe (7) on the tank unit.

MIXING WATER AND LIQUID CHEMICALS USING THE PRIME DETERGENT TANK

Concentrated liquids which dissolve readily in water may be mixed with water in the pump cavity by using the prime-detergent tank. The chemical to be mixed with water is placed in the prime-detergent tank after the pump unit has been primed. It is metered into the pump cavity using VALVE NO. 4. The water and chemical mixture is then discharged through the discharge hoses. Water should not be discharged to the tank unit during metering of liquid chemicals. The procedures for using two of the more common concentrated liquids, liquid detergent (Page 0028 00-2, item 9) and fire extinguishing foam forming liquid (Page 0028 00-2, item 13) for petroleum fires are given below.

MIXING WATER AND LIQUID CHEMICALS USING THE PRIME DETERGENT TANK - Continued

Liquid Detergent

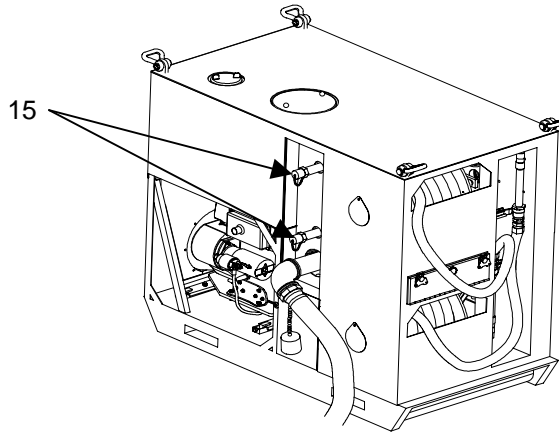

1. Heat the water in the tank to approximately 90°F (32.2°C) (Page 0007 00-12).

CAUTION

Hot water is present in the heater and will drain when blender hose is disconnected.

2. Disconnect the water heater. Cap both discharge pipes (15) on the connector panel immediately. Do not allow the pump to drain.

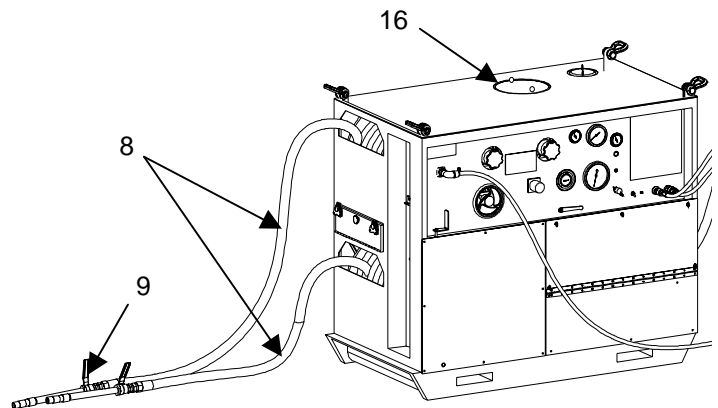
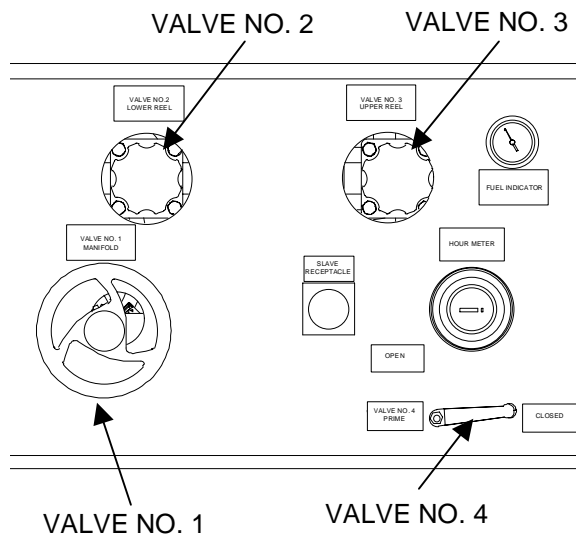

3. Remove prime detergent tank lid (16) and fill the prime-detergent tank with 1 pint of liquid detergent and water.
4. Open VALVE NO. 1. Unreel the discharge hoses (8) and open VALVES NO. 2 and 3 if both hose reels are to be used.
5. Start the pump unit. Open VALVE NO. 4 slightly to add the detergent mixture to the water.
6. Open valve (9) on the gun assembly and begin spraying liquid detergent mixture.
7. After spraying mission is complete, clean and store the apparatus according to applicable procedure listed in Work Package 0011 00.

MIXING WATER AND LIQUID CHEMICALS USING THE PRIME DETERGENT TANK - Continued

Fire Extinguishing Foam for Petroleum Fires

1. Prime and start the pump unit (Page 0006 00-1).

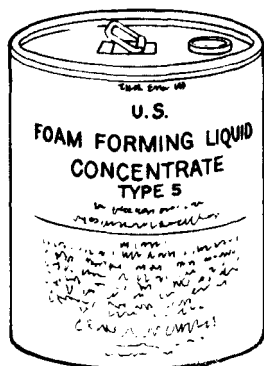

2. Fill the prime detergent tank with 5 gallons of foam forming liquid concentrate (Page 0028 00-2, item 13).

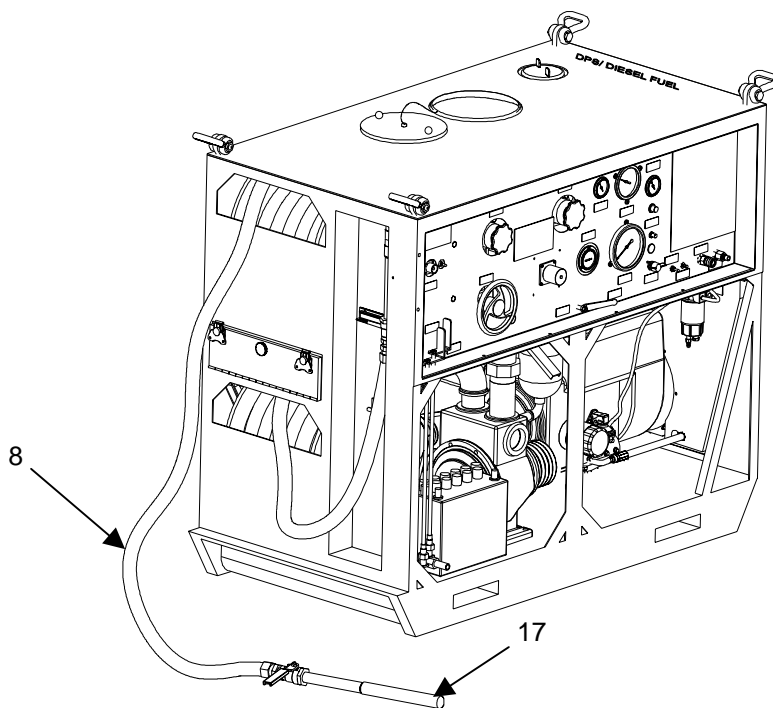

NOTE

Make sure caps are on both discharge pipes on the connector panel. Make sure the pump is primed and has not been drained.

3. Connect the fire hose foam nozzle (17) (obtain it from the pump unit tool box) to the discharge hose (8) of either the upper or lower hose reel (whichever is to be used). Put the slurry nozzle in the tool box for safekeeping. Unreel the discharge hose to be used.
4. Open VALVE NO. 1. Open VALVE NO. 2 LOWER REEL or VALVE NO. 3 UPPER REEL for this operation.
5. Turn VALVE NO. 4 PRIME (prime-detergent) approximately to ½ OPEN position.

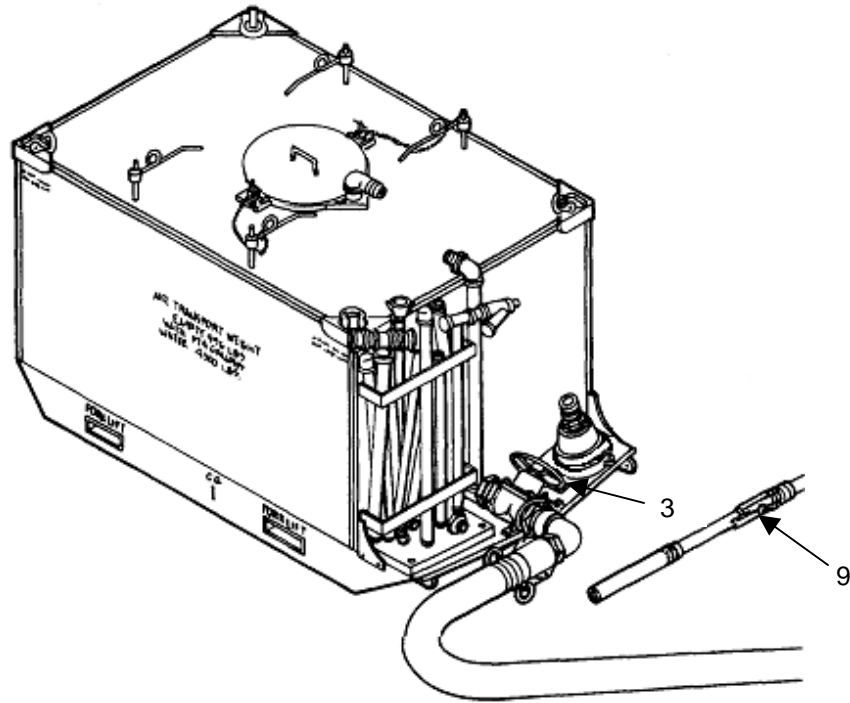
MIXING WATER AND LIQUID CHEMICALS USING THE PRIME DETERGENT TANK - Continued**Fire Extinguishing Foam for Petroleum Fires - Continued**

6. Open the tank drain valve (3) on the tank unit by turning valve handle approximately five full turns.
7. Open the valve (9) on the gun assembly and begin spraying foam-water mixture. The mixture should be thick and fluffy (not thin and watery). If necessary, turn tank drain valve (3) handle toward the closed position in one-fourth turn increments until the foam water mixture reaches proper consistency.
8. After the spraying mission is complete stop pump unit. Clean and store the apparatus according to applicable procedure listed in Work Package 0011 00.

END OF WORK PACKAGE

**OPERATOR
M12A1 DIESEL ENGINE DRIVEN DECONTAMINATION APPARATUS
NSN 4230-01-502-7224
OPERATION UNDER USUAL CONDITIONS:
SHOWERING AND HEATING WATER IN THE TANK**

INITIAL SETUP:

References

- WP 0006 00
- WP 0007 00
- WP 0011 00

GENERAL

Pump water for showering from either the tank unit or from a natural source. Before using water from the tank for showering personnel, inspect the tank for any evidence of contamination such as STB decontaminating agent, sodium hydroxide, sodium hypochlorite chemicals, calcium hypochlorite, or fire fighting foam.

Clean tank before filling with water for showering. A water temperature of 100°F is suitable for showering.

SHOWERING

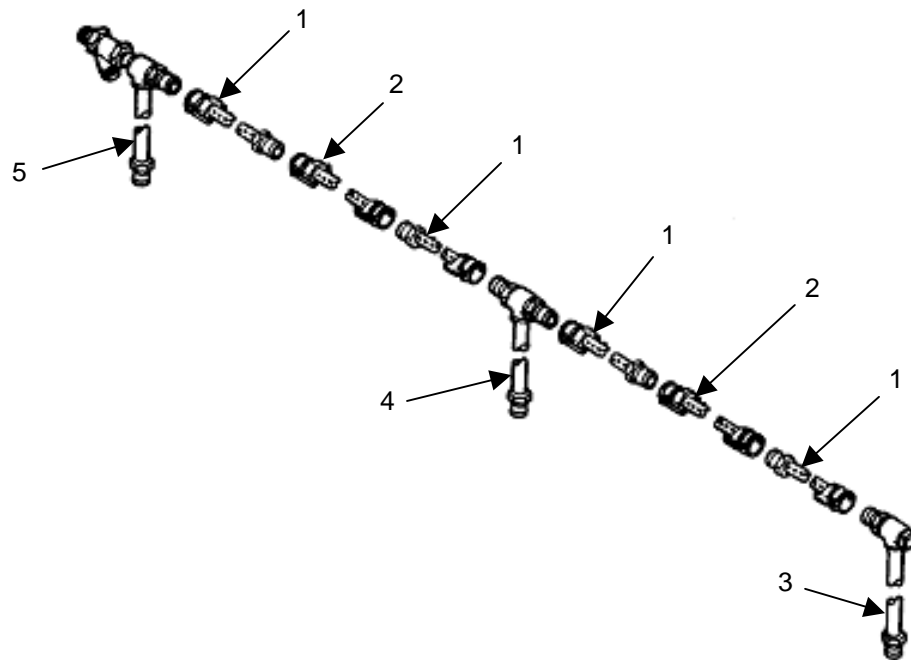

1. Remove the eighteen pipes from the storage bracket on the tank unit. Sort the pieces as you lay them on the ground.
2. Lay six top sections (four of item (1) and two of item (2)), one upper rear support (3), one upper center support (4), and one upper front support (5) in a line, as illustrated, and connect the couplers.

SHOWERING - Continued

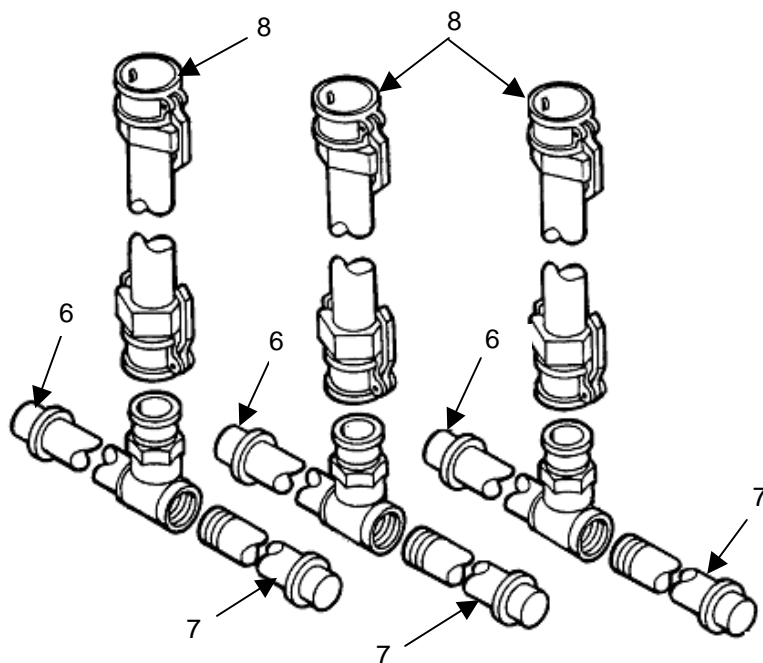

3. Assemble three horizontal supports (6) to three horizontal supports (7), as illustrated.
4. Connect three lower vertical supports (8) to three horizontal supports, as illustrated.

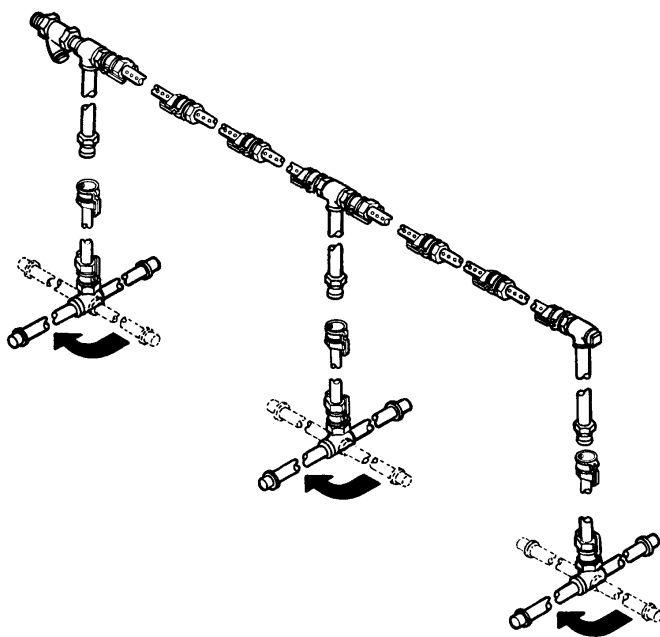

5. Connect three lower sections to the upper section. Stand upright and rotate three horizontal supports 90°, as illustrated.
6. Disconnect the gun assembly and adapter from the upper discharge hose. Connect the discharge hose to the shower. Inspect to see that the shower holes are aligned properly.

SHOWERING - Continued

| OPERATION NO | OPERATION | PREVIOUS OPERATION REQUIRED | SUCTION HOSE TO SOURCE | DISCHARGE TO TANK | DISCHARGE CONNECTION UPPER | DISCHARGE CONNECTION LOWER | VALVE #1 MANIFOLD | VALVE #2 LOWER REEL | VALVE #3 UPPER REEL | VALVE #4 PRIME DETERGENT | VALVE POSITION | REMARKS |
|--------------|----------------------|-----------------------------|------------------------|-------------------|----------------------------|----------------------------|-------------------|---------------------|---------------------|--------------------------|----------------|-----------------------------|
| | | | | | | | | | | | O—OPEN | |
| 7 | DISCHARGE UPPER REEL | 1 | S/T | ON | ON | X | X | O | X | | | *FROM HEATER **TO HEATER |
| | HOT WATER LOWER REEL | 1 | S/T | ON | ON | X | O | X | X | | | *FROM HEATER **TO HEATER |

7. Follow operation number 7 on the STARTING PROCEDURE instruction plate.
8. Connect the suction hose to the pump unit. Depending on mode of operation, connect the foot valve to the other end of the suction hose, or connect the suction hose to the tank drain valve.
9. Make other connections necessary for mode of operation.
10. Prime the pump and start the pump unit (Page 0006 00-1).
11. After the water heater has filled with water, start the heater (Page 0007 00-7).

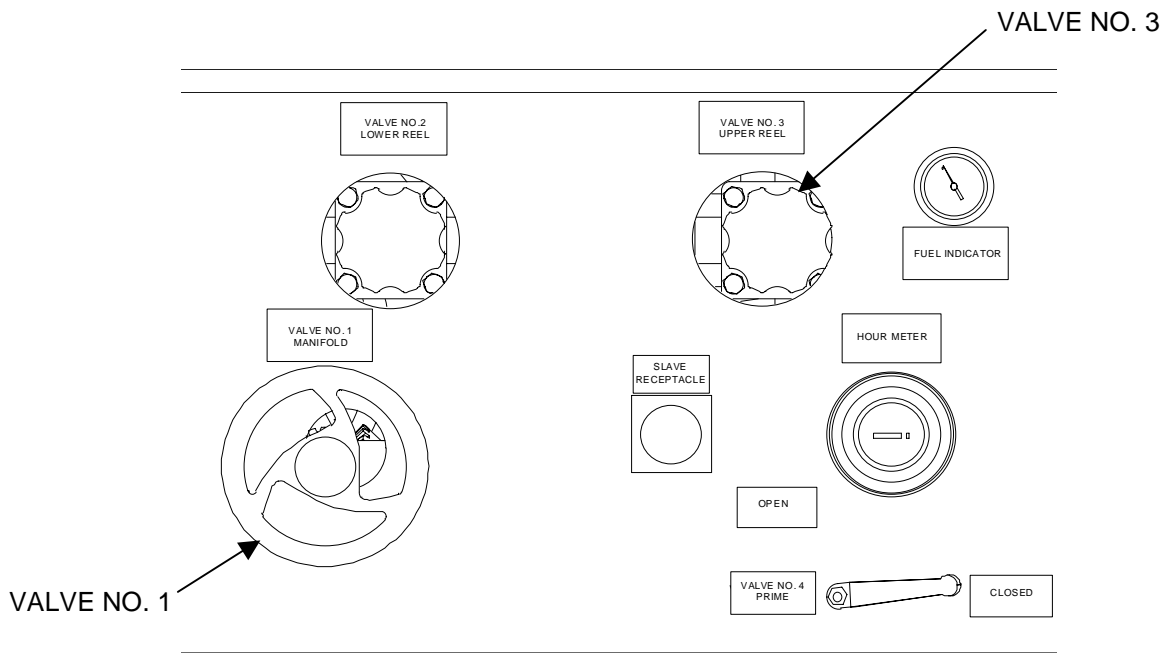

12. After water is heated, open VALVES NO. 1 and 3.

SHOWERING - Continued

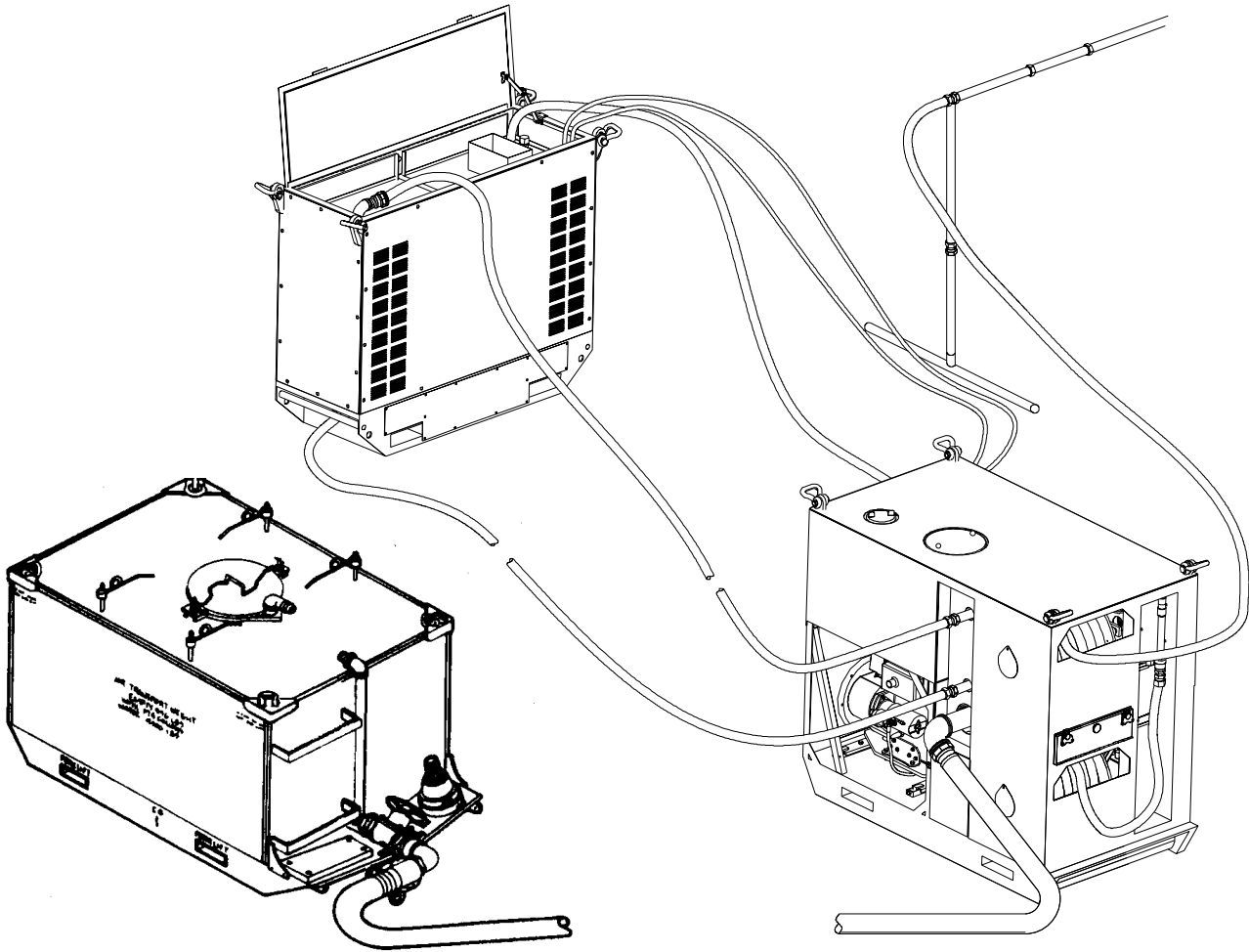

Showering personnel with water from the tank.

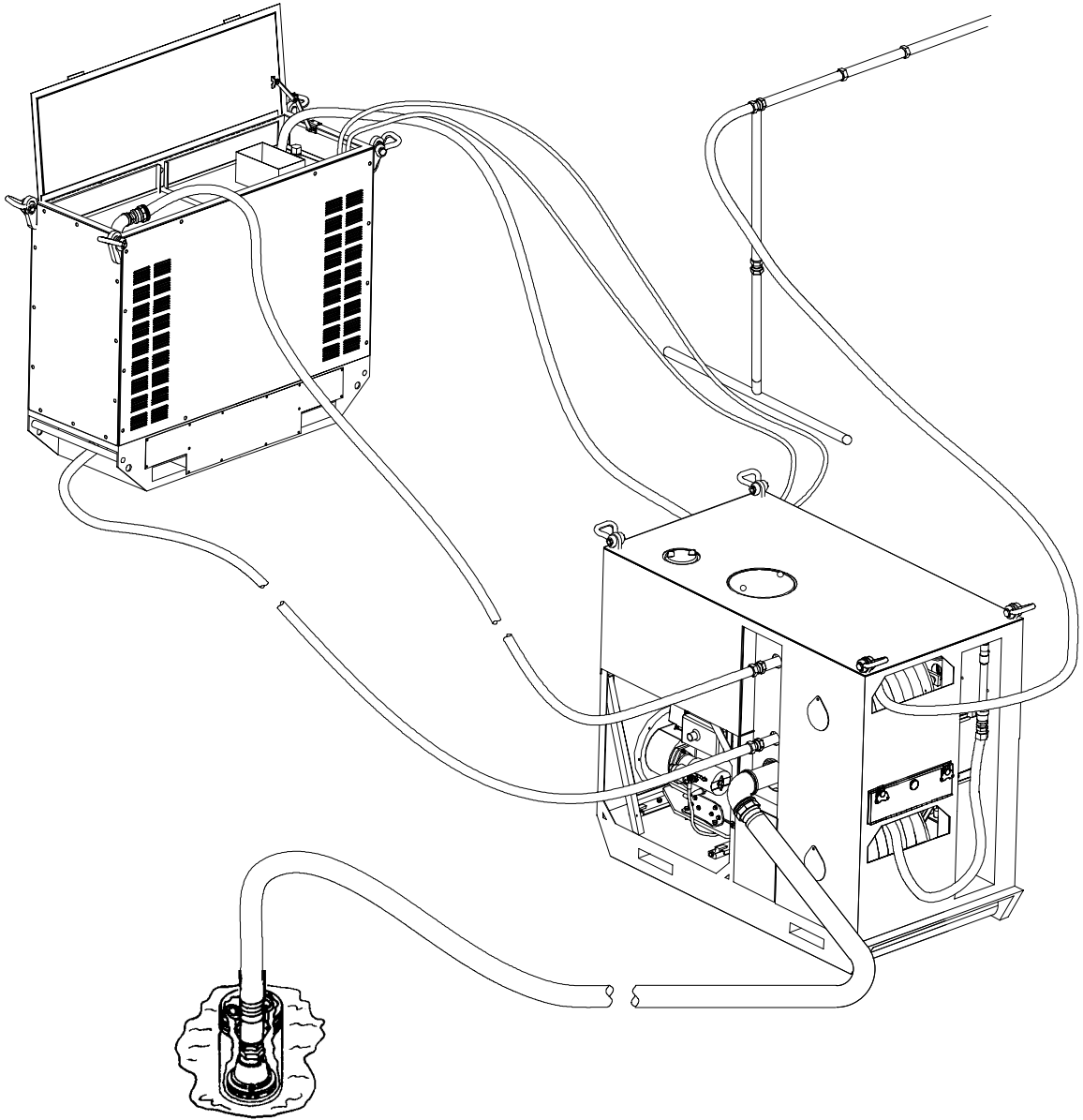
SHOWERING - Continued

Showering personnel with water drawn from a natural source.

SHOWERING - Continued

13. When mission is completed, shutdown the water heater (Page 0007 00-9).
14. After the water heater is shut down, stop the pump unit (Page 0006 00-7).
15. Disassemble the personnel shower assembly taking care to avoid burring pipes or fittings.

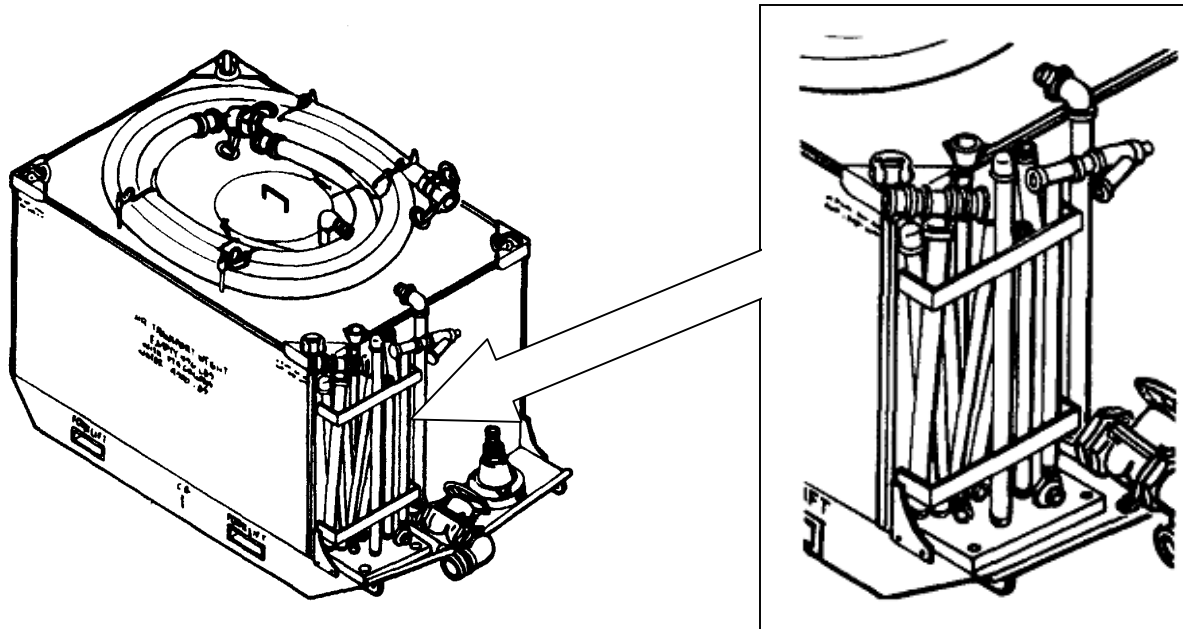
**CAUTION**

Always position six horizontal supports (pipes with solid caps) in the brackets so that the pipe caps are on top. Otherwise, water can be trapped in the pipe causing rust or the water can freeze and break the pipe.

16. Stow the shower assembly in the brackets on the tank unit assembly. The sections with solid caps should be stowed with the caps up to keep water from building up in the pipe.
17. Clean and store the apparatus according to the applicable procedure listed in WP 0011 00.

HEATING WATER IN THE TANK

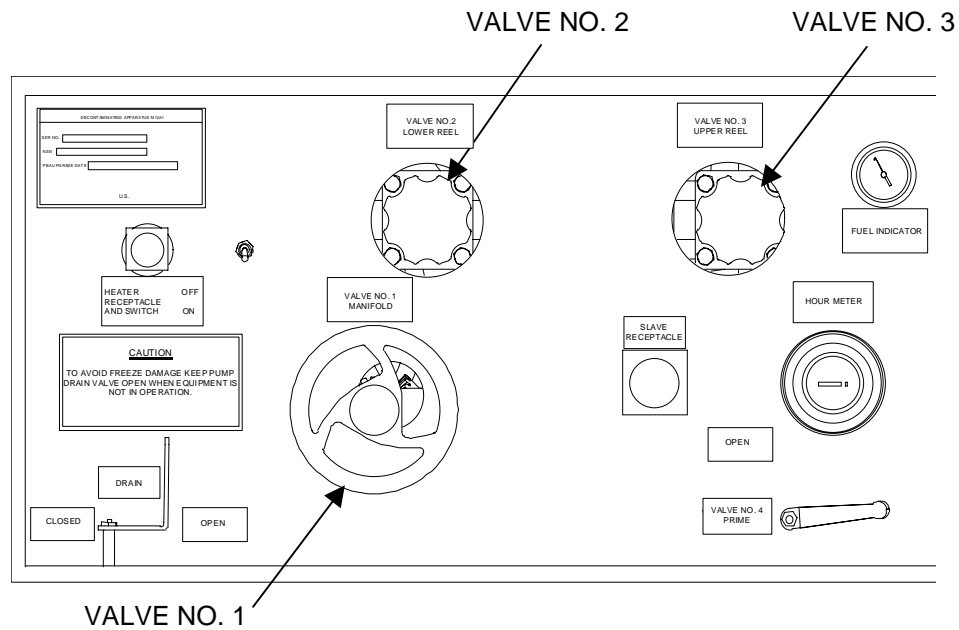

1. Close VALVES NO. 1, 2, and 3.

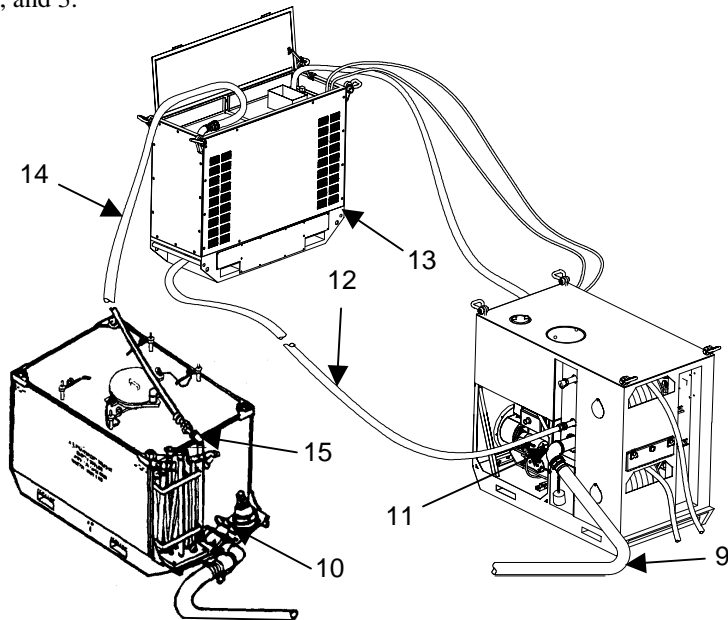

2. Connect one end of suction hose (9) to tank unit drain valve (10) and other end to suction connection on pump unit (11). Open tank drain valve (10).
3. Connect one end of blender hose (12) to bottom discharge connection on pump unit and other end to bottom connection on water heater (13).
4. Connect free end of heater unit water hose (14) to agitator connection (15) on tank unit and other end to upper connection on water heater.
5. Prime and start the pump unit (Page 0006 00-1).
6. Start and run the water heater (Page 0007 00-7).

HEATING WATER IN THE TANK - Continued

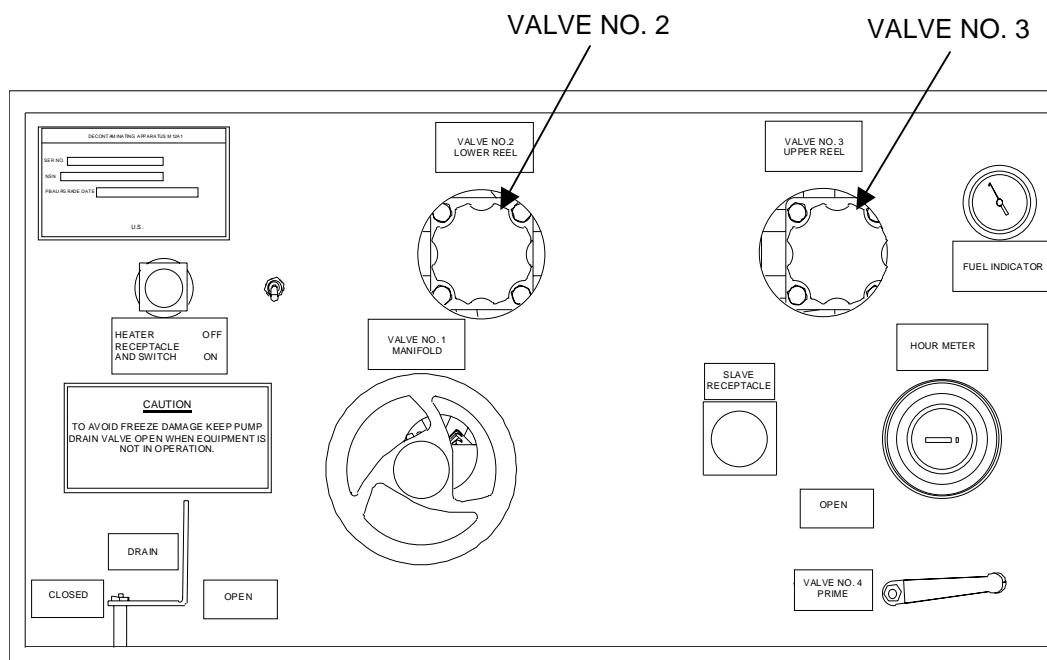

7. Hot water may be dispersed through upper and/or lower reels and out discharge hose(s), if VALVES NO. 2 and/or 3 are opened.
8. After the mission is complete, stop the water heater (Page 0007 00-9).
9. Stop the pump unit (Page 0006 00-7).
10. Clean and store the apparatus according to the applicable procedure listed in WP 0011 00.

END OF WORK PACKAGE

**OPERATOR
M12A1 DIESEL ENGINE DRIVEN DECONTAMINATION APPARATUS
NSN 4230-01-502-7224
OPERATION UNDER USUAL CONDITIONS:
DECALS AND INSTRUCTION PLATES**

INITIAL SETUP:

OPERATING INSTRUCTIONS ON DECALS AND INSTRUCTION PLATES

The nameplate for the decontaminating apparatus and identification plates for valves, instruments, and controls are located on the control panel of the pump unit. A STARTING PROCEDURE plate shows valve positions and operating procedures. Nameplates are also located on the pump, alternator, and engine. The nameplate and identification plates for the water heater are located on the front of the water heater.

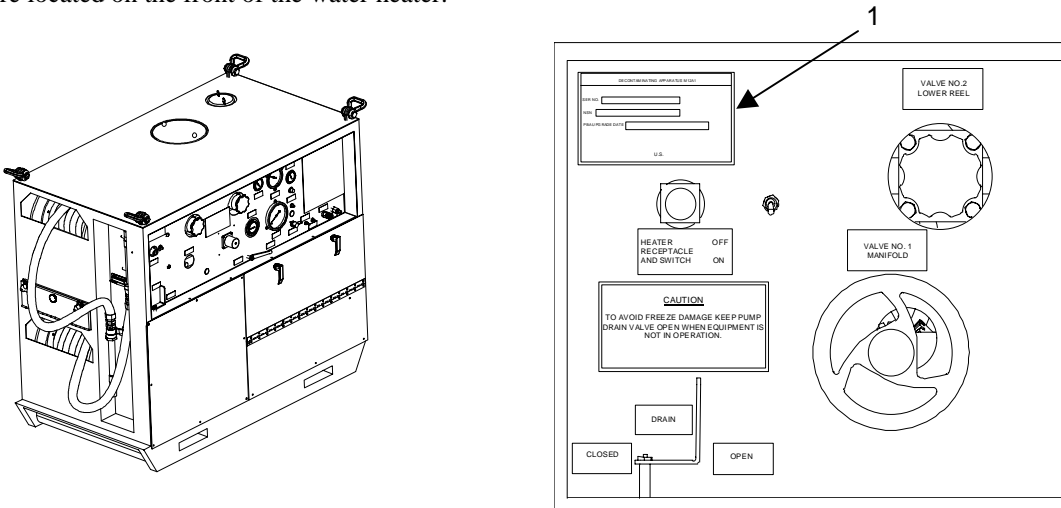

| Key | Plate |
|-----|--|
| 1 | M12A1 Decontaminating Apparatus Nameplate <div style="border: 1px solid black; padding: 10px; margin: 10px auto; width: fit-content;"> <p style="text-align: center;">DECONTAMINATING APPARATUS M12A1</p> <p>SER NO. <input style="width: 150px;" type="text"/></p> <p>NSN <input style="width: 150px;" type="text"/></p> <p>PBA UPGRADE DATE <input style="width: 150px;" type="text"/></p> <p style="text-align: center;">U.S.</p> </div> |

OPERATING INSTRUCTIONS ON DECALS AND INSTRUCTION PLATES - Continued

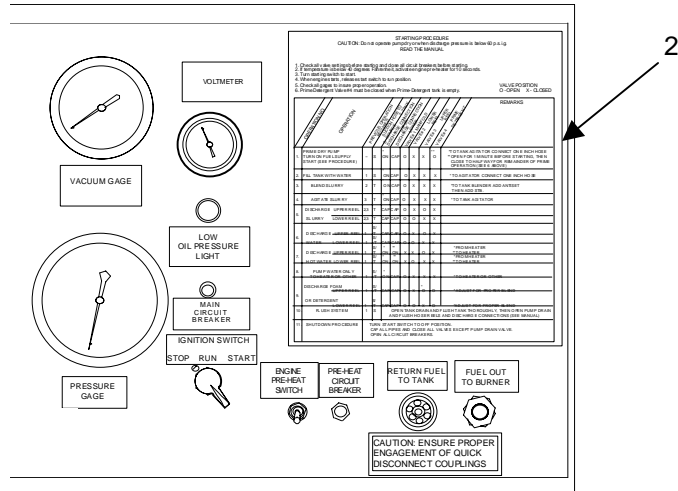
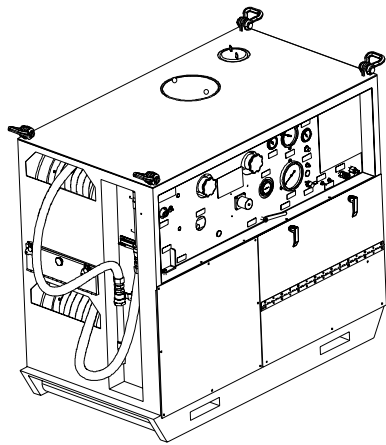

Key

Plate

2

STARTING PROCEDURE Instruction Plate

STARTING PROCEDURE
 CAUTION: Do not operate pump dry or when discharge pressure is below 60 p.s.i.g.
 READ THE MANUAL

1. Check all valve settings before starting and close all circuit breakers before starting.
2. If temperature is below 40 degrees Fahrenheit, activate engine pre-heater for 10 seconds.
3. Turn starting switch to start.
4. When engine starts, release start switch to run position.
5. Check all gages to insure proper operation.
6. Prime Detergent Valve #4 must be closed when Prime-Detergent tank is empty.

VALVE POSITION
 O - OPEN X - CLOSED

| OPERATION NO. | OPERATION | PREVIOUS OPERATION REQUIRED | SUCTION HOSE TO DISCHARGE | DISCHARGE CONNECTION | VALVE #1 MANIFOLD | VALVE #2 | VALVE #3 | VALVE #4 | UPPER REEL | PRIME DETERGENT | REMARKS |
|---------------|--|-----------------------------|---------------------------|----------------------|-------------------|----------|----------|----------|------------|-----------------|--|
| 1. | PRIME DRY PUMP TURN ON FUEL SUPPLY START (SEE PROCEDURE) | - | S | ON | CAP | O | X | X | O | | *TO TANK AGITATOR CONNECT ONE INCH HOSE **OPEN FOR 1 MINUTE BEFORE STARTING. THEN CLOSE TO HALFWAY FOR REMAINDER OF PRIME OPERATION (SEE 6 ABOVE) |
| 2. | FILL TANK WITH WATER | 1 | S | ON | CAP | O | X | X | X | | *TO AGITATOR CONNECT ONE INCH HOSE |
| 3. | BLEND SLURRY | 2 | T | ON | CAP | O | X | X | X | | *TO TANK BLENDER ADD ANTISEPTIC THEN ADD STB. |
| 4. | AGITATE SLURRY | 3 | T | ON | CAP | O | X | X | X | | *TO TANK AGITATOR |
| 5. | DISCHARGE UPPER REEL SLURRY LOWER REEL | 2,3 | T | CAP | CAP | O | X | O | X | | |
| 6. | DISCHARGE UPPER REEL WATER LOWER REEL | 1 | S/ T | CAP | CAP | O | X | O | X | | |
| 7. | DISCHARGE UPPER REEL HOT WATER LOWER REEL | 1 | S/ T | ON | ON | X | X | O | X | | *FROM HEATER **TO HEATER |
| 8. | PUMP WATER ONLY TO HEATER OR OTHER | 1 | S/ T | ON | CAP | O | X | X | X | | *TO HEATER OR OTHER |
| 9. | DISCHARGE FOAM UPPER REEL OR DETERGENT LOWER REEL | 1 | S/ T | CAP | CAP | O | X | O | O | | *ADJUST FOR PROPER BLEND |
| 10. | FLUSH SYSTEM | 1 | S | | | | | | | | *ADJUST FOR PROPER BLEND |
| 11. | SHUTDOWN PROCEDURE | | | | | | | | | | TURN START SWITCH TO OFF POSITION. CAP ALL PIPES AND CLOSE ALL VALVES EXCEPT PUMP DRAIN VALVE. OPEN ALL CIRCUIT BREAKERS. |

OPERATING INSTRUCTIONS ON DECALS AND INSTRUCTION PLATES - Continued

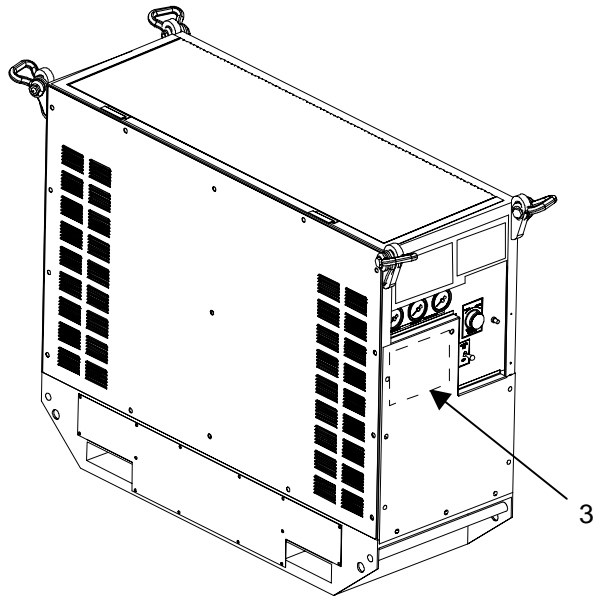

| Key | Plate |
|-----|---|
| 3 | <p data-bbox="467 961 730 993">Water Heater Nameplate</p> <div data-bbox="521 1024 1463 1570" style="border: 1px solid black; padding: 10px;"> <p data-bbox="976 1066 1019 1094" style="text-align: center;">U.S.</p> <p data-bbox="553 1115 1398 1142">NOMENCLATURE: HEATER, WATER, LIQUID FUEL, SKID MOUNTED 600 GPM, M2</p> <p data-bbox="553 1163 1040 1190">NATIONAL STOCK NUMBER 4410-01-502-6866</p> <p data-bbox="553 1211 1203 1247">SERIAL NUMBER 356---</p> <p data-bbox="553 1268 1162 1295">DESIGN ACTIVITY: U.S. ARMY EDGEWOOD ARSENAL, MD</p> <p data-bbox="553 1316 1357 1344">RATING: 100 DEGREES FAHRENHEIT TEMPERATURE RISE 600 GPH WATER</p> <p data-bbox="553 1365 951 1392">SPEC NO. 24 VDC POWERED, DIESEL</p> </div> |

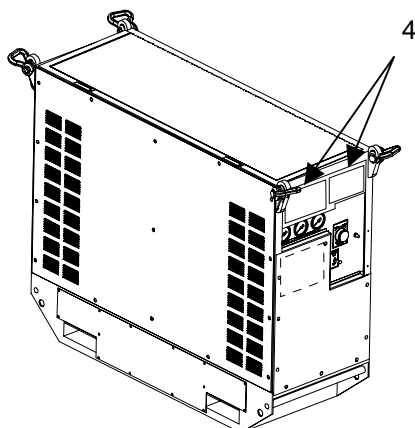

OPERATING INSTRUCTIONS ON DECALS AND INSTRUCTION PLATES - Continued

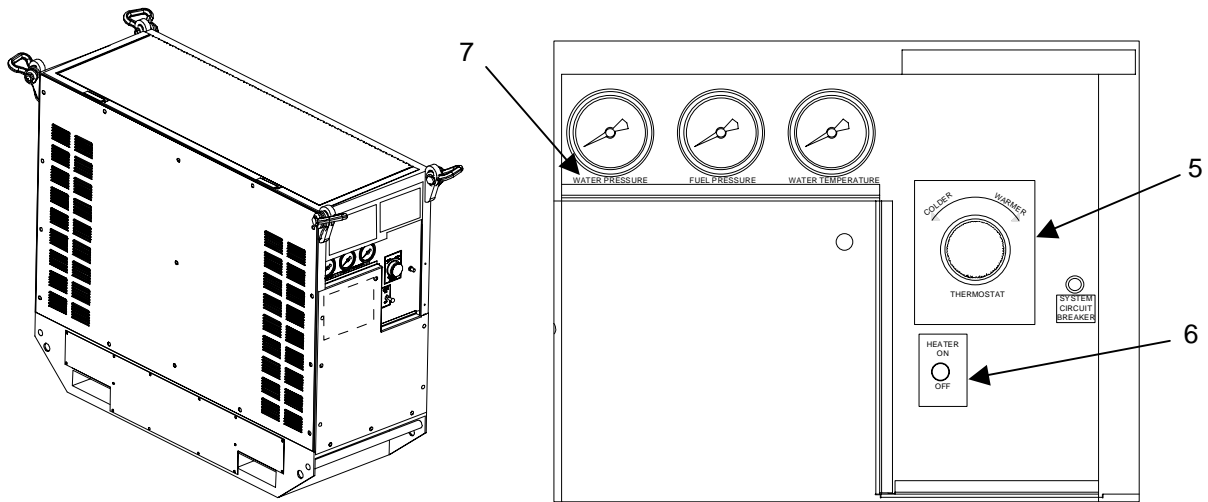

| Key | Plate |
|-----|--|
| 4 | <p data-bbox="370 814 818 842">Water Heater Operating Instruction Plates</p> <div data-bbox="555 873 1252 1381" style="border: 1px solid black; padding: 10px; margin-bottom: 10px;"> <p style="text-align: center;"><u>HEATER OPERATING INSTRUCTIONS.</u></p> <p><u>TO ACTIVATE HEATER:</u></p> <ol style="list-style-type: none"> 1. CONNECT WATER HEATER INLET AND OUTLET WATER HOSE. 2. MAKE CERTAIN HEATER IS FULL OF WATER BEFORE PROCEEDING. 3. REMOVE FUEL LINES FROM STORAGE COMPARTMENT AND CONNECT TO PUMPING UNIT WITH QUICK CONNECTORS. VERIFY CONNECTIONS ARE SECURE. 4. BE CERTAIN HEATER SWITCH IS IN "OFF" POSITION. 5. CONNECT POWER CABLE TO 24 VOLT D.C. POWER SUPPLY ON PUMPING UNIT. 6. ALLOW HEATER TO OPERATE IN "ON" POSITION FOR TWO MINUTES WITH THERMOSTAT OFF. 7. BE CERTAIN WATER IS FLOWING THROUGH THE HEATER. 8. NOTE THAT FUEL PRESSURE SHOULD BE STABLE AT 150 PSI. 9. ADJUST THERMOSTAT TO DESIRED TEMPERATURE. IF FIRE IS NOT ESTABLISHED IN TEN SECONDS RETURN THERMOSTAT SWITCH TO OFF POSITION AND DO NOT ATTEMPT TO RESTART UNTIL EXPERIENCED PERSONNEL SERVICES HEATER. </div> <div data-bbox="555 1402 1252 1906" style="border: 1px solid black; padding: 10px;"> <p><u>TO DEACTIVATE HEATER:</u></p> <ol style="list-style-type: none"> 10. TURN THERMOSTAT TO OFF POSITION. 11. ALLOW WATER TO FLOW THROUGH HEATER FOR AT LEAST 3 MINUTES OR UNTIL DISCHARGE WATER IS APPROXIMATELY 100 DEGREES FAHRENHEIT. 12. DISCONNECT UNIT FROM D.C. POWER SUPPLY AND COIL CABLE IN STORAGE COMPARTMENT. 13. DISCONNECT FUEL LINES AT PUMPER AND STORE IN TOP STORAGE COMPARTMENT. 14. DISCONNECT OUTLET WATER HOSE AT BOTH ENDS AND COIL NEATLY IN STORAGE COMPARTMENT. DISCONNECTING INLET HOSE AT BOTTOM OF HEATER WILL DRAIN UNIT. 15. CLOSE AND LATCH STORAGE COMPARTMENT COVER. </div> |

OPERATING INSTRUCTIONS ON DECALS AND INSTRUCTION PLATES - Continued

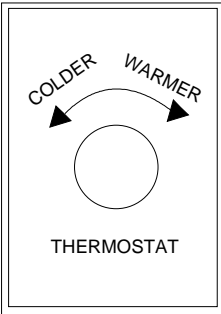
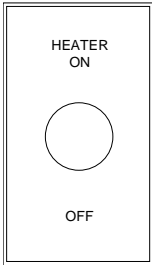

| Key | Plate |
|-----|---|
| 5 | <p>THERMOSTAT Plate</p>  |
| 6 | <p>Heater Control Switch Plate</p>  |
| 7 | <p>Gage Identification Plate</p>  |

OPERATING INSTRUCTIONS ON DECALS AND INSTRUCTION PLATES - Continued

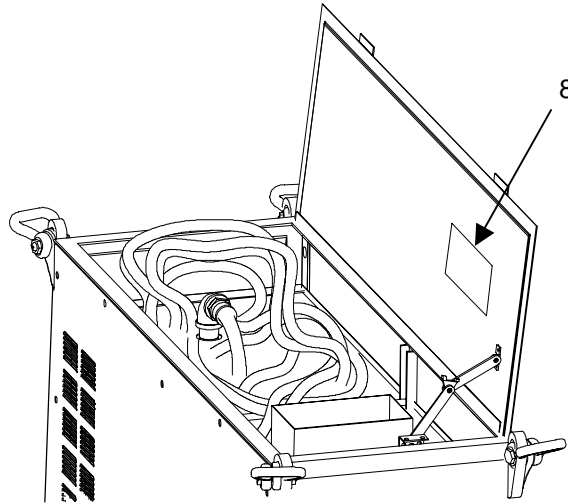

| Key | Plate |
|-----|--|
| 8 | Warning Stencil or Decal <div data-bbox="604 945 1198 1314" style="border: 2px solid black; padding: 10px; text-align: center;"> <p><u>DANGER</u></p> <p>KEEP CLEAR OF EXHAUST STACK DURING OPERATION</p> </div> |

OPERATOR
M12A1 DIESEL ENGINE DRIVEN DECONTAMINATION APPARATUS
NSN 4230-01-502-7224
OPERATION UNDER USUAL CONDITIONS:
PREPARATION FOR MOVEMENT

INITIAL SETUP:**Materials/Parts**

- Grease, Automotive and Artillery (Page 0028 00-2, item 15)
- Lubricating Oil, General Purpose (Page 0028 00-3, item 18)
- Lubricating Oil, General Purpose (Page 0028 00-3, item 19)
- Rag, Wiping (Page 0028 00-3, item 21)

PREPARATION FOR MOVEMENT

Refer to Table 1.

Table 1. Cleaning and Storage Procedures After a Spraying Mission.

| Item No. | Expected Idle Time | Procedures |
|----------|--------------------|--|
| 1 | Less than 24 hours | Start the pump unit. Flush the interior of the tank, agitator pipe, blender pipe, and prime-detergent tank with water. Unreel the discharge hoses from both hose reels and open the gun assembly valves. Stop the pump unit. Open VALVES NO. 1, 2, 3, and 4, and the pump DRAIN valve. Drain the hoses. Close the orifice-and-deflector assemblies on both slurry nozzles. Reel the discharge hoses neatly on the hose reels. Stow the gun assemblies in their brackets. When the pump is drained, close VALVES NO. 1, 2, 3, and 4. Leave pump DRAIN valve open. Install the hopper-blender cover. Disconnect and drain the suction hose. Install the blender hose inside the suction hose. Stow the suction hose and the blender hose on top of the tank unit. Close the tank drain valve after all water has drained from the tank unit. Install the foot valve assembly in the bracket on the tank unit skid. Drain the boiler of the water heater. Drain the water hose; stow it in the storage compartment. Install the cover panels and dust cover over the pump unit. |
| 2 | 24 to 48 hours | Drain the slurry from the tank unit. Clean the M12A1 decontaminating apparatus (item No. 1 above). Lubricate the pump by pouring 3 pints of special-preservative general purpose lubricating oil (PL-M or PL-S) (Page 0028 00-3, item 18 or 19) mixed with 3 gallons of water into the prime-detergent tank. Open VALVE NO. 4 and allow the oil-water mixture to run into the pump. Start the pump unit and operate it for 30 seconds. Stop the pump unit. Open the pump DRAIN valve and allow the oil-water mixture to run out to suitable container and dispose according to local SOP. Check that prime-detergent tank is empty. Close valve NO. 4 and leave pump drain valve open. |

PREPARATION FOR MOVEMENT**Table 1. Cleaning and Storage Procedures After a Spraying Mission - Continued.**

| Item No. | Expected Idle Time | Procedures |
|-----------------|---------------------------|--|
| 3 | Over 48 hours | Drain (item No. 1 above) and clean (item No. 2 above) the M12A1 decontaminating apparatus. Wipe the exterior surfaces of the pump, piping, valves, and other metal parts with a cloth saturated in oil to retard corrosion. Wipe the generator, battery, engine housing, and fuel tank with a clean, dry cloth. Coat the battery terminals with GAA (Page 0028 00-2, item 15) (See Lubrication Instructions in WP 0020 00). Inspect the water level of the battery cells. Install the cover panels and dust cover over the pump unit assembly. |

END OF WORK PACKAGE

**OPERATOR
M12A1 DIESEL ENGINE DRIVEN DECONTAMINATION APPARATUS
NSN 4230-01-502-7224
OPERATION UNDER UNUSUAL CONDITIONS**

INITIAL SETUP:

Materials/Parts

Diesel Fuel, Arctic (Page 0028 00-2, item 11)
Grease, Automotive and Artillery (Page 0028 00-2, item 15)

References

TM 9-6140-200-14
WP 0008 00
WP 0011 00
WP 0020 00

OPERATION IN COLD WEATHER

WARNING

Wear protective gloves and eye protection when fueling the decontaminating apparatus.

CAUTION

Do not use an antifreeze mixture when mixing chemicals. A heat-releasing chemical reaction can occur when decontaminating agents are added.

Leave pump drain valve open at all times when equipment is not in use. This will prevent pump damage during freezing weather.

For operation in cold weather below 32°F (0°C), winterize the decontaminating apparatus. Slurry becomes thicker as the temperature lowers and should not be used at fluid temperatures below 32°F (0°C).

Winterizing

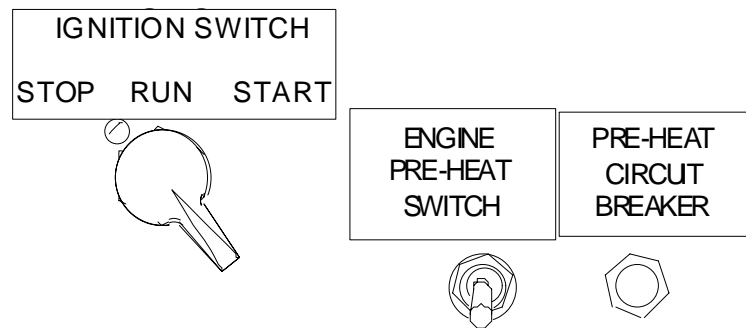

1. During operation in extreme cold temperatures below 0°F (-17.8°C), use the ENGINE PREHEAT SWITCH on the control panel for 1 minute to get the engine started. If the engine does not run smoothly, hold switch for an additional minute until engine operates smoothly.

OPERATION IN COLD WEATHER - Continued**Winterizing - Continued****WARNING**

The engine and water heater exhausts can be lethal. Do not inhale these gases. A chemical-biological mask does not protect against carbon monoxide. When the decontaminating apparatus is to be operated, the exhaust gases must be vented away from the operator or outside of an enclosed area to prevent carbon monoxide poisoning.

2. Open the two hinged cover panels on the pump unit.
3. Lubricate the engine with the grade of oil to be used in winter conditions according to Lubrication Instructions (WP 0020 00). Fill the fuel tank with diesel fuel arctic grade (Page 0028 00-2, item 11) if temperatures are consistently below 32°F (0°C).

CAUTION

Circulate only clear water through the water heater to avoid damage.

4. Preheat the water to prevent water from freezing before it can be used.

Equipment Failure

If the equipment fails (e.g., broken drive belts, engine trouble, etc.) during cold weather while liquid is being sprayed, drain the apparatus.

CAUTION

When using the decontaminating apparatus at temperature below 32°F (0°C), any liquid left in the piping, pump tank, or discharge may freeze and damage the equipment. If operations are interrupted, flush and drain the decontaminating apparatus.

1. Open the gun assembly valves on the discharge hoses. Unreel the hoses from the hose reels to drain as much liquid as possible out of the discharge hoses and slurry nozzles.
2. Open the pump DRAIN valve and open VALVE NO. 4 PRIME to drain as much liquid as possible out of the pump and prime-detergent tank.
3. Disconnect the suction hose from the tank unit assembly and pump unit assembly. Open the tank drain valve and drain as much liquid as possible from the tank. Drain the suction hose, blender hose, and water heater.
4. Notify unit maintenance personnel to perform the necessary repairs.

Spraying Water**CAUTION**

Residual liquid in the piping, pump, and discharge hoses may freeze and damage the equipment if the water's circulation is interrupted.

At temperatures below 32°F (0°C), spray water as follows:

1. Winterize the decontaminating apparatus (Page 0012 00-1).

OPERATION IN COLD WEATHER - Continued

Spraying Water - Continued

2. Operate the engine and agitate the water that is in the tank unit through the pump unit until ready to spray. Heat water to a satisfactory temperature above freezing by using the water heater.
3. Start spraying and continue spraying without interruption until the tank unit is empty. If water in the tank begins to freeze, use the water heater to heat the water, unless tank is loaded with chemicals.
4. Drain the decontaminating apparatus.

Spraying Slurry

At temperatures below 32°F (0°C), spray slurry as follows:

1. Winterize the decontaminating apparatus (Page 0012 00-1).
2. Fill the tank unit with water. Heat water to a satisfactory temperature above freezing using water heater. Disconnect water heater. Add the antiset compound, STB decontaminating agent, and silicone antifoam agent (Page 0008 00-1). Agitate the mixture constantly until ready to spray.
3. Start spraying. If spraying is stopped for 5 minutes or more, the slurry is likely to freeze.

Procedure if Spraying of Slurry is Stopped

If spraying of slurry is stopped for more than 5 minutes at temperatures below 32°F (0°C), proceed as follows:

1. If possible do not discontinue spraying operation until the tank unit assembly is empty or until the decontaminating mission is completed.
2. Drain the slurry from the discharge hoses and piping and the tank unit assembly.
3. Flush and drain the M12A1 decontaminating apparatus (WP 0011 00).

Completion of Spraying Mission

1. After completing the spraying mission, flush the M12A1 decontaminating apparatus (WP 0011 00).
2. Lubrication. Lubricate as required according to Lubrication Instructions (WP 0020 00).

OPERATION IN SNOW AND ICE

Keep the decontaminating apparatus free of snow and ice as much as possible. The pump unit is completely enclosed with cover panels to protect the pump and engine. Use the canvas dust cover to protect the controls on the panel.

OPERATION IN SALT WATER AREAS AND HIGH HUMIDITY

When operating in areas close to salt water or where the humidity is high, keep all exterior surfaces well painted. Watch for corrosion. Remove corrosion from electrical terminals by cleaning. Coat the battery terminals with GAA (Page 0028 00-2, item 15) according to Lubrication Instructions (WP 0020 00). Refer to Lubrication Instructions (WP 0020 00) for engine protection and precautions to be observed. Refer to TM 9-6140-200-14 for battery protection and precautions to be observed.

OPERATION IN EXTREME HEAT

Inspect the rubber hoses once a week for signs of wear and damage. Rubber deteriorates rapidly in extreme heat.

For extended operation in hot ambient conditions, keep both the front and rear panel of the pump unit open. This will tend to reduce the operating temperature of the engine cavity.

OPERATION IN SAND AND DUST

Keep the cover panels and dust cover in place as much as possible. Position the pump unit in a direction that will afford the greatest protection to the engine compartment. Keep lubricants free from dust and grit. Do not overlubricate as dust and grit adhere to the lubricant and will work into lubricated areas.

END OF WORK PACKAGE

CHAPTER 3

TROUBLESHOOTING PROCEDURES
FOR
M12A1 DIESEL ENGINE-DRIVEN DECONTAMINATING APPARATUS

**OPERATOR
M12A1 DIESEL ENGINE DRIVEN DECONTAMINATION APPARATUS
NSN 4230-01-502-7224
TROUBLESHOOTING INDEX**

INTRODUCTION TO TROUBLESHOOTING

The Troubleshooting Index lists the common malfunctions which you may find during the operation or maintenance of the decontaminating apparatus or its components. You should perform the tests/inspections and corrective actions (WP0014 00, Table 1) in the order listed.

This manual cannot list all malfunctions that may occur, nor all tests or inspections and corrective actions. If a malfunction is not listed or is not corrected by listed corrective actions, notify unit maintenance personnel.

TROUBLESHOOTING INDEX

| Malfunction or Symptom | Work Package/Page |
|--|-------------------|
| PUMP UNIT | |
| Belts Squeal | 0014 00-5 |
| Engine Cranks But Will Not Start | 0014 00-1 |
| Engine Fails to Start | 0014 00-1 |
| Engine Runs Irregularly | 0014 00-2 |
| Excessive Smoke Coming From Engine Exhaust During Operation | 0014 00-3 |
| Pump Inoperative (Fails to Operate) | 0014 00-3 |
| Pump Vibrates Excessively | 0014 00-4 |
| Pump Overheats or is Noisy | 0014 00-5 |
| Pump Seal Leaks | 0014 00-5 |
| Uncontrolled Temperature Rise (Temperature Reading Greater Than 70°F Above Thermostat Setting) | 0014 00-3 |
| WATER HEATER | |
| Additives Fail to Mix in Solution | 0014 00-9 |
| Burner Fails to Ignite | 0014 00-5 |
| Burner Ignites, But No Hot Water Discharge | 0014 00-9 |
| Burner Sputters Out and Diesel Engine Stops | 0014 00-6 |
| Class III Leak in System | 0014 00-9 |
| Water Not Hot Enough | 0014 00-8 |
| Water Too Hot | 0014 00-8 |

END OF WORK PACKAGE

**OPERATOR
M12A1 DIESEL ENGINE DRIVEN DECONTAMINATION APPARATUS
NSN 4230-01-502-7224
TROUBLESHOOTING PROCEDURES**

INITIAL SETUP:

Materials/Parts

Diesel Fuel, Arctic (WP 0028 00, item 11)
Grease, Automotive and Artillery (WP 0028 00, item 15)
Turbine Fuel, Aviation, JP-8 (WP 0028 00, item 27)

References

WP 0006 00
WP 000800
WP 0016 00
WP 0019 00
WP 0020 00
WP 0023 00

TROUBLESHOOTING PROCEDURES

Table 1. Troubleshooting.

MALFUNCTION

**TEST OR INSPECTION
CORRECTIVE ACTION**

PUMP UNIT

1. ENGINE FAILS TO START.

Step 1. Check that MAIN CIRCUIT BREAKER is pressed in.
If not, depress MAIN CIRCUIT BREAKER.

Step 2. Check battery for loose terminal.
Tighten battery terminal.

Step 3. Check voltmeter on control panel.
If voltage is below 24V, use slave cable in slave receptacle to jump-start pump unit.

2. ENGINE CRANKS BUT WILL NOT START.

Step 1. Check temperature.
If temperature is below 32°F (0°C), preheat engine for 1 minute and attempt restart.

Step 2. Check fuel source.
a. If fuel level is low, fill with fuel.
b. If fuel is thickened (below 20°F), notify Unit Maintenance.

TROUBLESHOOTING PROCEDURES - Continued

Table 1. Troubleshooting - Continued.

MALFUNCTION

TEST OR INSPECTION

CORRECTIVE ACTION

PUMP UNIT - Continued

2. ENGINE CRANKS BUT WILL NOT START - Continued.

Step 3. Check for air lock in fuel line.

Open vent in fuel filter/water separator, using adjustable wrench. Bleed air from fuel line and close vent.

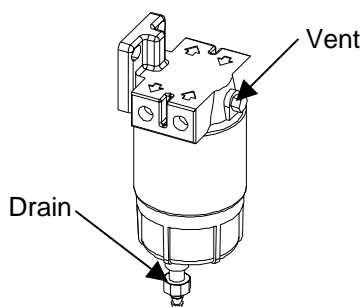

Step 4. Check fuel filter/water separator for water.

Drain fuel filter/water separator (see WP 0016 00, PMCS, task 36) and attempt restart.

Step 5. Pump manual primer on engine fuel pump while cranking engine.

If engine still will not start, notify Unit Maintenance.

Step 6. Check starter and battery terminals for tightness and corrosion.

Clean terminals (Page 0016 00-2).

If engine still will not start, notify Unit Maintenance.

3. ENGINE RUNS IRREGULARLY

WARNING

Diesel fuel is flammable. Keep open flames, sparks, and ignition sources 50 feet (15 meters) away at all times. Have a CO₂ or dry chemical fire extinguisher available at all times. Avoid spilling fuel.

Step 1. While engine is running, check fuel supply level.

If fuel tank is more than 1/2 empty, turn off engine and fill 1/2 full of fuel, restart engine and go on to Step 2.

Step 2. Check that temperature is above 32°F (0°C).

- a. If temperature is below 32°F (0°C), preheat engine for 1 minute.
- b. If engine still runs irregularly, check fuel source for thickened fuel.
- c. If fuel is congealed, shut down system and notify Unit Maintenance.

TROUBLESHOOTING PROCEDURES - Continued

Table 1. Troubleshooting - Continued.

MALFUNCTION

TEST OR INSPECTION

CORRECTIVE ACTION

PUMP UNIT - Continued

3. ENGINE RUNS IRREGULARLY - Continued.

- Step 3.* Shut down system (WP 0006 00). Open engine air filter and check for foreign material.
- a. Remove debris or replace filter element (WP 0024 00) as necessary.
 - b. If engine still runs irregularly, notify Unit Maintenance.

- Step 4.* Shut down system. Drain fuel filter/water separator (see WP 0016 00, PMCS, task 36). Attempt restart.

If engine still runs irregularly, notify Unit Maintenance.

4. EXCESSIVE SMOKE COMING FROM ENGINE EXHAUST DURING OPERATION.

- Step 1.* Shut down system (WP 0006 00). Open engine air filter and check for foreign material.
- a. Remove debris or replace filter element (WP 0024 00) as necessary.
 - b. If engine still runs irregularly, notify Unit Maintenance.

- Step 2.* Shut down system. Drain fuel filter/water separator, prime fuel system and attempt restart. If there is still excessive smoke, notify Unit Maintenance.

5. PUMP INOPERATIVE (FAILS TO OPERATE).

- Step 1.* Check to see that VALVE NO. 4 PRIME is closed after priming pump and before prime-detergent tank is empty.
- a. Close VALVE NO. 4 PRIME.
 - b. Refill prime-detergent tank with 10 gallons of water.
 - c. Open VALVE NO. 4 PRIME and prime pump.
 - d. Close VALVE NO. 4 PRIME before prime-detergent tank is empty.

- Step 2.* To check to see if VALVE NOS. 1, 2, or 3 is closed, open one or more of these valves. See instruction on STARTING PROCEDURE instruction plate.

- Step 3.* Check for loose or broken belts.
Adjust drive belts (WP 0023 00) if required.

- Step 4.* Check to see if the connection is loose on the suction line.
Tighten connection.

TROUBLESHOOTING PROCEDURES - Continued

Table 1. Troubleshooting - Continued.

MALFUNCTION

TEST OR INSPECTION

CORRECTIVE ACTION

PUMP UNIT - Continued

5. PUMP INOPERATIVE (FAILS TO OPERATE)- Continued.

Step 5. Check to see if suction hose is plugged with dirt.
Clean suction hose.

Step 6. If foot valve is used, check to see if it is clogged.
Clean foot valve.

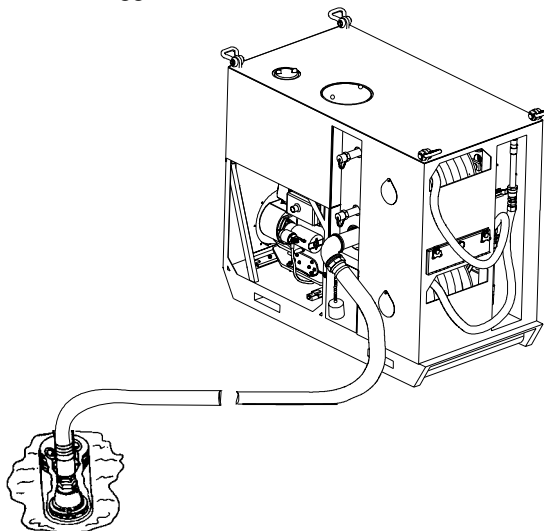

Step 7. Check pump suction. Open VALVE NO. 4 PRIME and remove suction hose from inlet piping. Operate pump and hold the palm of your hand against the suction inlet. If there is no pull against the palm of your hand, the pump is bad. Notify Unit Maintenance.

6. PUMP VIBRATES EXCESSIVELY.

Step 1. Visually inspect to determine if pump mounting is loose. Shut down system. Tighten mounting nuts and adjust belts (WP 0023 00).

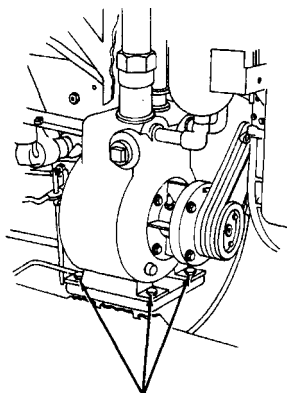

**PUMP MOUNTING
0014 00-4**

TROUBLESHOOTING PROCEDURES - Continued

Table 1. Troubleshooting - Continued.

| | | |
|--------------------|---------------------------|--------------------------|
| MALFUNCTION | TEST OR INSPECTION | CORRECTIVE ACTION |
|--------------------|---------------------------|--------------------------|

PUMP UNIT - Continued

6. PUMP VIBRATES EXCESSIVELY - Continued.

Step 2. Check to see if pump drive pulley on pump shaft is loose, broken, or bent.
Shut down system and notify Unit Maintenance.

7. PUMP OVERHEATS OR IS NOISY.

Check logbook to see if lubrication fitting on pump was lubricated.
Lubricate pump with correct lubricant according to WP 0020 00.

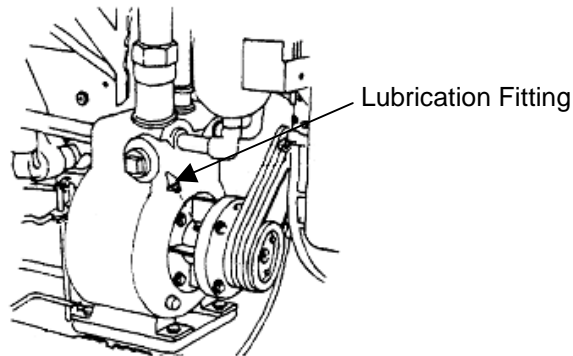

8. PUMP SEAL LEAKS.

Notify Unit Maintenance.

9. BELTS SQUEAL.

Step 1. Stop system and check belt tension (WP 0023 00).
Restart system. If belts still squeal, notify Unit Maintenance.

Step 2. Check that VOLTMETER, VACUUM GAGE, and WATER PRESSURE gage on the control panel read properly.

- a. If gages do not read properly, notify Unit Maintenance.
- b. If gages read properly, continue mission and notify Unit Maintenance upon completion of mission.

TROUBLESHOOTING PROCEDURES - Continued

Table 1. Troubleshooting - Continued.

MALFUNCTION**TEST OR INSPECTION****CORRECTIVE ACTION**

PUMP UNIT - Continued

10. ADDITIVES FAIL TO MIX IN SOLUTION.

- Step 1.* Check to see that decontaminating agent and water are blended properly.
Blend decontaminating agent and water (WP 0008 00) in accordance with instructions on STARTING PROCEDURE instruction plate.
- Step 2.* Check for improper connections.
Connect hoses properly (WP 0008 00) in accordance with instructions on STARTING PROCEDURE instruction plate.
- Step 3.* Check for settled solution and plugged agitator or blender pipe.
Clean obstructions and remove settled slurry from equipment (WP 0019 00, PMCS procedure 30).

WATER HEATER

1. BURNER FAILS TO IGNITE.

- Step 1.* Check that electrical cable is connected to pump unit, the HEATER RECEPTACLE AND SWITCH is ON, and HEATER ON/OFF switch is ON.
Plug in electrical cable switch HEATER RECEPTACLE AND SWITCH to ON, and switch HEATER ON/OFF switch to ON.
- Step 2.* Check that fuel hoses are attached and not pinched.
a. Reattach hoses.
b. Reposition hoses to avoid pinching.
- Step 3.* Verify that MAIN CIRCUIT BREAKER on pump unit control panel is ON.
Push circuit breaker to ON position.
- Step 4.* Check for tripped SYSTEM CIRCUIT BREAKER on heater control panel.
If circuit breaker is tripped, push back in.
- Step 5.* Run until fuel pressure remains steady at 150 psi.
If fuel pressure does not remain steady, notify Unit Maintenance.
- Step 6.* Check for water in fuel filter/water separator bowl on heater unit.
Empty water from fuel filter/water separator bowl (WP 0016 00, PMCS procedure 36).
- Step 7.* Check for air space, air bubbles or foam in fuel filter/water separator bowl.
If any of the above conditions exist, notify Unit Maintenance.

TROUBLESHOOTING PROCEDURES - Continued

Table 1. Troubleshooting - Continued.

| MALFUNCTION | TEST OR INSPECTION | CORRECTIVE ACTION |
|--------------------|---------------------------|--------------------------|
|--------------------|---------------------------|--------------------------|

WATER HEATER - Continued

2. BURNER SPUTTERS OUT AND DIESEL ENGINE STOPS.

Step 1. See if there is fuel in the pump unit tank.
Refill fuel tank.

Step 2. Check FUEL PRESSURE gage reading (as illustrated) to assure that the fuel pressure is correct.
If pressure gage is not at 150 psi, notify Unit Maintenance.

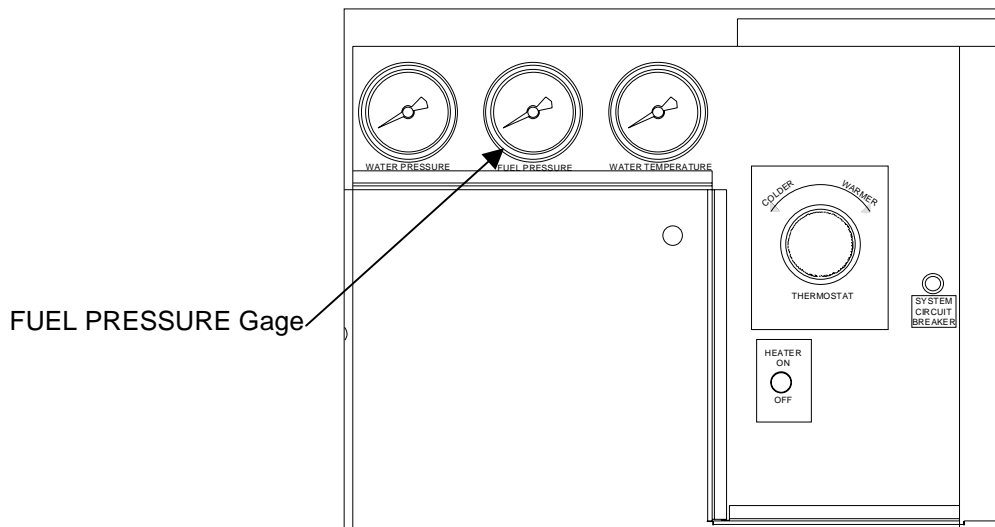

Step 3. Check to see if air is leaking into the hose where the quick disconnect joins to the pump unit. Apply GAA lubricant (WP 0028 00, item 15) to quick disconnect for test.
If burner operates normally, then resumes sputtering, air leak is present.
Notify Unit Maintenance.

Step 4. Check main power cable for dirt, obstructions, or loose or broken connections.
If heater motor is running erratically, or if cable is hot to touch, notify Unit Maintenance.

TROUBLESHOOTING PROCEDURES - Continued

Table 1. Troubleshooting - Continued.

MALFUNCTION

TEST OR INSPECTION

CORRECTIVE ACTION

WATER HEATER - Continued

2. BURNER SPUTTERS OUT AND DIESEL ENGINE STOPS. - Continued

Step 5. Check HEATER RECEPTACLE AND SWITCH on pump unit for loose power cable connection to be sure there is power.

Tighten power cable connection.

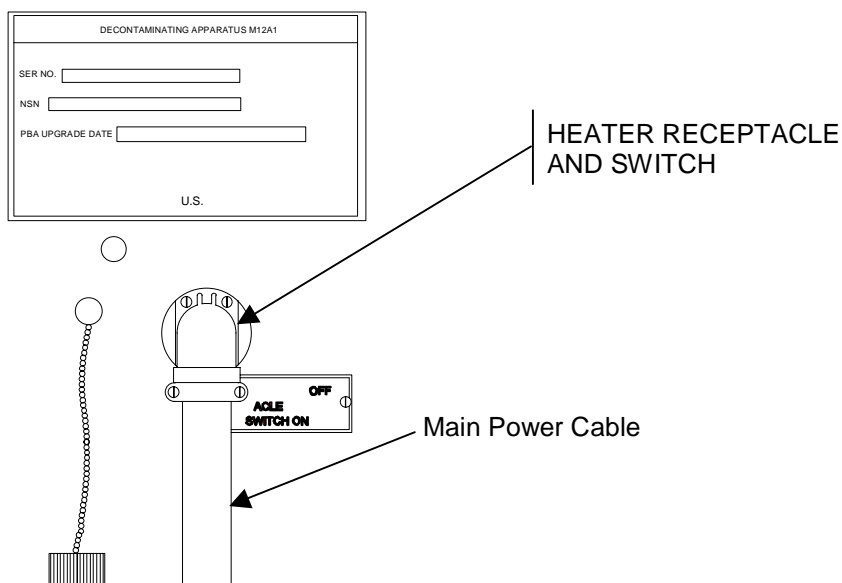

Step 6. Remove side panels of water heater and visually check for leaking fuel lines.
Notify Unit Maintenance.

Step 7. Remove side panel of water heater and check for air space, air bubbles or foam in fuel filter/water separator bowl.
If any of the above conditions exist, notify Unit Maintenance.

3. WATER TOO HOT (TEMPERATURE READING GREATER THAN 70°F ABOVE THERMOSTAT SETTING).

Step 1. Check WATER TEMPERATURE gage on front of heater. If gage indicates temperature of 200° F or higher, the automatic control and safety devices of the water heater are defective.
Shut off heater and notify Unit Maintenance.

TROUBLESHOOTING PROCEDURES - Continued

Table 1. Troubleshooting - Continued.

MALFUNCTION

TEST OR INSPECTION

CORRECTIVE ACTION

WATER HEATER - Continued

3. WATER TOO HOT (TEMPERATURE READING GREATER THAN 70°F ABOVE THERMOSTAT SETTING). - Continued

- Step 2.* Check to determine if water flow is too slow.
Increase water flow by closing VALVE NO. 1 completely.

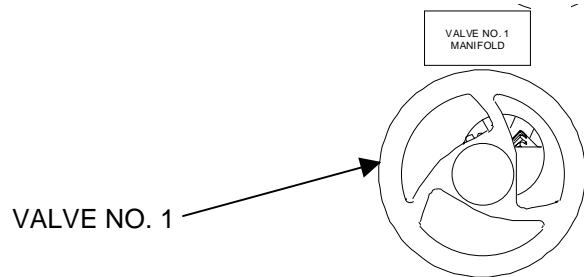

- Step 3.* If shower assembly is used, check for clogged strainer in shower assembly.
Shut down equipment and clean screen in strainer.

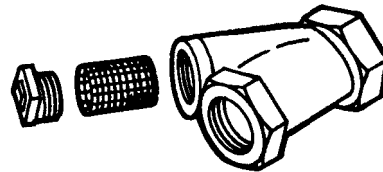

- Step 4.* If discharge hoses are used, check for clogged discharge hoses.
Flush discharge hoses.

4. WATER NOT HOT ENOUGH.

- Step 1.* Check for rapid flow rate of water.
Adjust VALVE NO. 1 to show proper flow rate and correct temperature. If correct temperature cannot be reached, notify Unit Maintenance.
- Step 2.* Check for leaking fuel lines.
Notify Unit Maintenance.
- Step 3.* Check for improperly connected hoses.
Connect hoses properly.

TROUBLESHOOTING PROCEDURES - Continued
Table 1. Troubleshooting - Continued.

MALFUNCTION**TEST OR INSPECTION****CORRECTIVE ACTION**

WATER HEATER - Continued
5. BURNER IGNITES, BUT NO HOT WATER DISCHARGE.

Step 1. Check that VALVE NO. 1 is closed completely.

Close VALVE NO. 1.

Step 2. Check control panel settings and ensure spray wand is open and water is flowing.

a. Set burner to ON and set thermostat to 180°F (82°C).

b. If there is still no hot water, notify Unit Maintenance.

6. CLASS III LEAK IN SYSTEM.

Step 1. Inspect quick release couplings on water hoses for leaks.

Ensure gaskets are present and that quick release couplings are fully engaged.

Step 2. Inspect discharge hose for leaks.

a. If leak is at gasket, replace hose gasket from on-board spares.

b. If hose is leaking, notify Unit Maintenance to replace hose.

Step 3. Inspect gun assembly valve(s) for leaks.

Continue operation with one wand and notify Unit Maintenance.

Step 4. Inspect heater and agitator hoses for leaks.

a. Tighten loose threaded couplings.

b. Ensure that hose is on barb and tighten clamp.

c. If leak continues, notify Unit Maintenance.

Step 5. Inspect hose reels for leaks.

Continue operation with one wand and notify Unit Maintenance.

Step 6. Inspect quick release couplings on fuel lines for leaks.

a. Ensure that locking ring is fully engaged.

b. If leak continues, notify Unit Maintenance.

END OF WORK PACKAGE

CHAPTER 4

MAINTENANCE INSTRUCTIONS
FOR
M12A1 DIESEL ENGINE-DRIVEN DECONTAMINATING APPARATUS

**OPERATOR
M12A1 DIESEL ENGINE DRIVEN DECONTAMINATION APPARATUS
NSN 4230-01-502-7224
PREVENTIVE MAINTENANCE CHECKS AND SERVICES (PMCS) INTRODUCTION**

INITIAL SETUP:**References**

DA Form 2404/5988-E
DA PAM 738-750
WP 0016 00
WP 0017 00
WP 0018 00
WP 0019 00

GENERAL

Before. Checks and services performed prior to the equipment leaving its containment area or performing its intended mission. Always keep in mind the CAUTIONS and WARNINGS. Perform your BEFORE PMCS.

During. Checks begin when the equipment is being used in its intended mission. Always keep in mind the CAUTIONS and WARNINGS. Perform your DURING PMCS.

After. Checks and services begin when the equipment is taken out of its mission mode or returned to its containment area. Be sure to perform your AFTER PMCS.

Quarterly. Perform quarterly checks and services every 90 days unless equipment is in permanent storage.

IF YOUR EQUIPMENT FAILS TO OPERATE

Troubleshoot with proper equipment. Report any deficiencies with the proper forms. See DA PAM 738-750.

PMCS PROCEDURES

Work Packages 0016 00 through 0019 00 contain operator's PMCS procedures. The procedures are arranged in a logical sequence requiring a minimum amount of time and motion on the part of the person(s) performing them and are arranged so there will be a minimum of interference between person(s) performing checks simultaneously on the same end item.

Item No. Column. Checks and services are numbered in chronological order regardless of interval. Use this column as a source of item numbers for the "TM Number" column on DA Form 2404/5988-E, Equipment Inspection and Maintenance Worksheet, in recording results of PMCS.

Manhour Column. This column lists the manhours required for the item to be checked or serviced.

Interval Column. The words in the Interval column indicate when the checks or services are to be done as follows:

a. If a given check is performed before, during, or after an operation, the word BEFORE, DURING, or AFTER will be in this column, respectively.

b. If the same check is made at two or more intervals, the appropriate words will appear in the column.

Location, Item to Check/Service Column. Indicates location and/or the item to be checked and/or serviced. The items to be inspected are identified by as few words, usually the common name, as will clearly identify the item, e.g., "Drive Belts."

PMCS PROCEDURES - Continued

Procedure Column. This column briefly describes the procedure by which the check is performed. It contains all the information required to perform the checks and services, including appropriate tolerances, adjustment limits, and instrument gage readings.

Not Fully Mission Capable If: Column. This column contains the criteria that will cause the equipment to be classified as not mission capable because of inability to perform its primary mission. An entry in this column will:

- a. Identify conditions that make the equipment not mission capable for readiness reporting purposes.
- b. Deny use of the equipment until corrective maintenance has been performed.

SPECIAL INSTRUCTIONS

Leakage definitions for operator PMCS shall be classified as follows:

- | | |
|-----------|--|
| Class I | Seepage of fluid (as indicated by wetness or discoloration) not great enough to form drops. |
| Class II | Leakage of fluid great enough to form drops but not enough to cause drops to drip from item being checked/inspected. |
| Class III | Leakage of fluid great enough to form drops that fall from the item being checked/inspected. |

CAUTION

Equipment operation is allowable with minor leakages (Class I or II). Of course, you must consider the fluid capacity in the item/system being checked/inspected. When in doubt, notify your supervisor.

When operating with Class I or Class II leaks, continue to check fluid levels as required in your PMCS.

Class III leaks should be reported to your supervisor or Unit Maintenance.

END OF WORK PACKAGE

**OPERATOR
M12A1 DIESEL ENGINE DRIVEN DECONTAMINATION APPARATUS
NSN 4230-01-502-7224
GENERAL CLEANING INSTRUCTIONS AND
BEFORE OPERATION PREVENTIVE MAINTENANCE CHECKS AND SERVICES (PMCS)**

INITIAL SETUP:**Materials/Parts**

Brush (Page 0028 00-1, item 3)
 Cleaning Compound, Solvent (Page 0028 00-2, item 7)
 Grease, Automotive and Artillery (Page 0028 00-2, item 15)
 Lubricating Oil (Page 0028 00-2, item 16 or 17)
 Rag, Wiping (Page 0028 00-3, item 21)
 Sodium Bicarbonate (Page 0028 00-3, item 22)

References

WP 0020 00
 WP 0023 00

GENERAL CLEANING INSTRUCTIONS

The pump unit, tank unit, and water heater should be cleaned once a week to maintain their appearance and to enable each item to function properly. Use hot, soapy water and a brush to remove hardened slurry or dirt from the exterior surfaces, gun and nozzle assemblies, hoses, the personnel shower assembly, and the tank unit.

WARNING

Fire and explosion danger exist when solvent cleaning compound is used. Make sure that equipment is dry before operations begin.

CAUTION

Do not wash the interior of the pump unit or the water heater with solvent cleaning compound. Do not wash the control panels with water. Rinse all parts washed with soap and water with clean water. Dry all parts thoroughly.

Control Panels. Wipe all switches and gages with a wiping rag (Page 0028 00-3, item 21). Stubborn stains, oil, or grease may be removed with a cloth dampened with solvent cleaning compound (Page 0028 00-2, item 7).

Unpainted Metal Parts and Interior of Pump Unit and Water Heater . Clean with a wiping rag (Page 0023 00-3, item 21) dampened with solvent cleaning compound (Page 0028 00-2, item 7) and dry thoroughly.

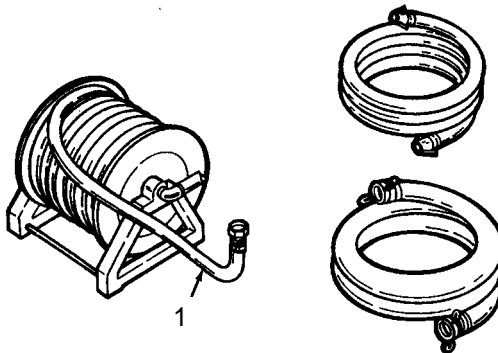

Hoses. Flush the hoses with hot water. Wash the exterior of the discharge hose (1) with hot, soapy water. Dry all parts thoroughly. Clean metal parts with a cloth dampened with solvent cleaning compound (Page 0028 00-2, item 7), if required.

GENERAL CLEANING INSTRUCTIONS - Continued**WARNING**

When working around or on the storage battery, always disconnect the ground cable first. Wear eye protection and protective gloves when working with storage battery. The storage battery contains acid which can blind or burn you. Do not allow battery acid to get on clothing.

Battery. Clean the battery with a dry cloth (Page 0028 00-3, item 21). If the battery is corroded, clean with a scrub brush (Page 0028 00-1, item 3) (any brush without wire bristles) dipped in a solution of bicarbonate of soda (baking soda) (Page 0028 00-3, item 22) and water. After the foaming action stops, flush the exterior surfaces of the battery with clean water and wipe dry with a clean cloth. To prevent corrosion, coat the terminals (2) and cable connections (3) with GAA lubricant (Page 0028 00-2, item 15) after connecting the battery cables, positive first, then negative.

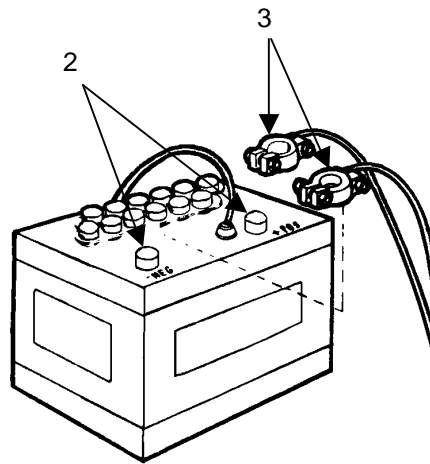

Water Heater Electrical Power Cable. Keep the electrical power cable (4) as clean as possible at all times. Avoid passing the cable through pools of water. Wipe the cable assembly and the 90-degree electrical plug connection with a dry rag (Page 0028 00-3, item 21).

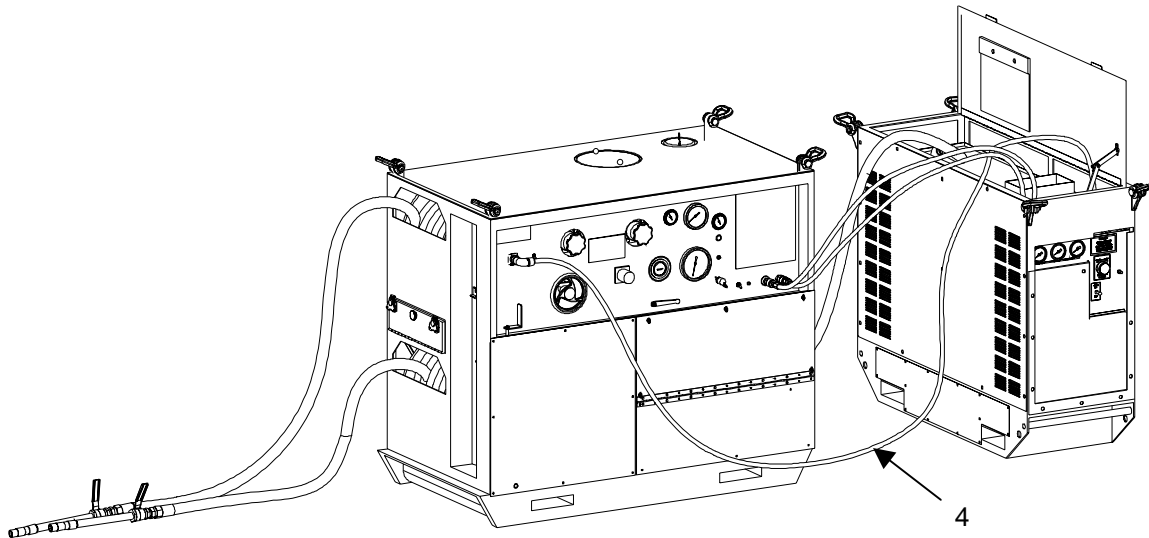

OPERATOR'S PREVENTIVE MAINTENANCE CHECKS AND SERVICES (PMCS)

Table 1. Before Operation PMCS for M12A1 DED Decontaminating Apparatus.

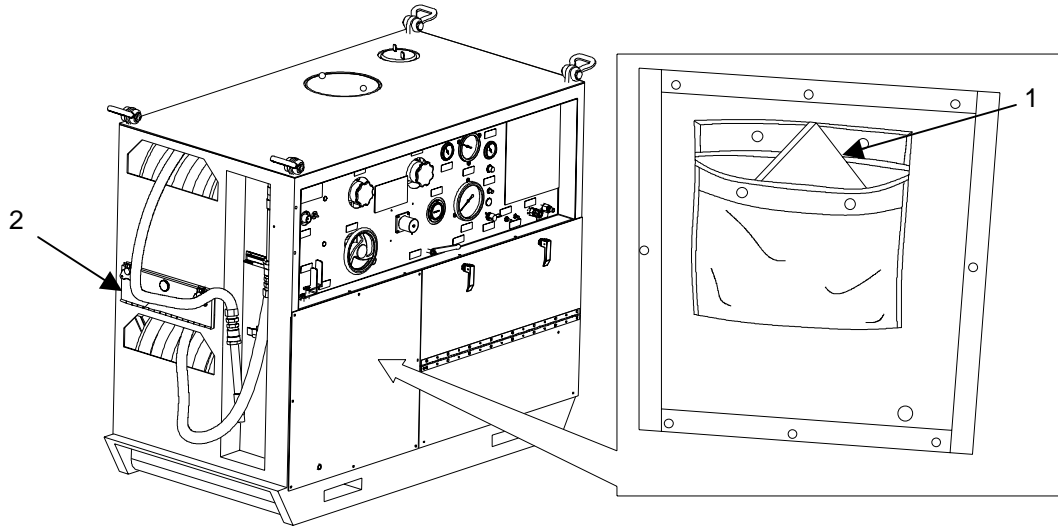

| Item No. | Interval | Man Hour | Item to be Checked/ Serviced | Procedure | Not Fully Mission Capable If: |
|----------|----------|----------|------------------------------|---|--|
| 1 | BEFORE | | Publications | <p style="text-align: center;">NOTE</p> <p>Within designated interval, perform these checks in the order listed.</p> <p>See that TM 3-4230-237-10 is present in the canvas pouch on the pump unit cover panel and is usable. Insure all URGENT MWOs have been applied.</p> | Any URGENT MWOs have not been applied. |
| 2 | BEFORE | | M12A1 Decon | <p style="text-align: center;">NOTE</p> <p>Check continuously for evidence of leaks, loose or missing hardware, bolts, nuts, or clamps, and unusual noises.</p> <p>a. Make sure all of the on-board tools and required spare parts (WP 0027 00) are in the tool box between the pump unit upper and lower hose reels.</p> <p>b. Make sure one crank handle is in the tool box between the pump unit upper and lower hose reels.</p> <p>c. Check that the units are complete and undamaged.</p> | One or more of the units are incomplete, damaged, or inoperable. |

OPERATOR'S PREVENTIVE MAINTENANCE CHECKS AND SERVICES (PMCS) - Continued

Table 1. Before Operation PMCS for M12A1 DED Decontaminating Apparatus - Continued.

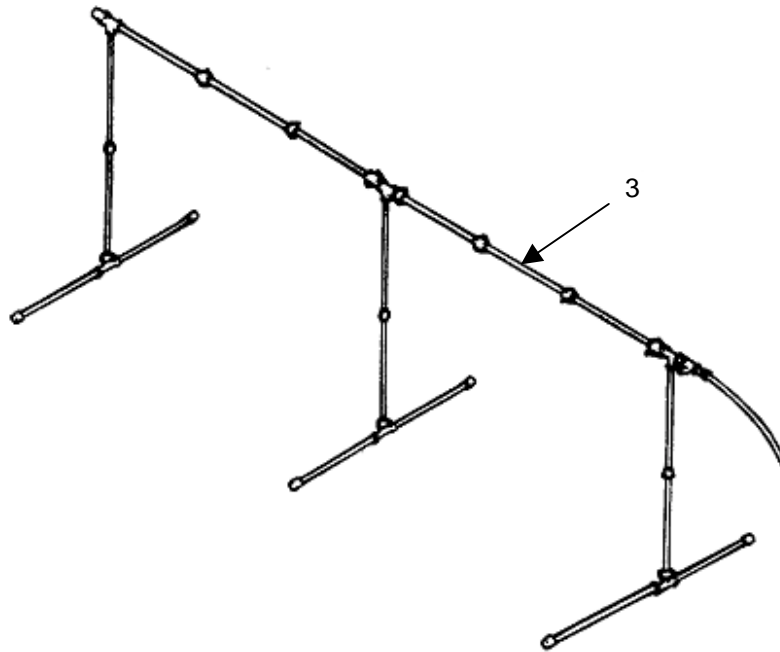

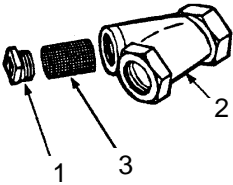
| Item No. | Interval | Man Hour | Item to be Checked/ Serviced | Procedure | Not Fully Mission Capable If: |
|----------|----------|----------|------------------------------|--|---|
| 3 | BEFORE | | Personnel Shower Assembly | <p>a. Inspect the exterior surfaces of the pipes and fittings for out of round and broken parts.</p> <p>b. Make sure the shower outlet holes in the six pieces of pipe are open.</p> <p style="text-align: center;">WARNING</p> <p style="text-align: center;">Fire and explosion danger exist when solvent cleaning compound is used. Make sure that equipment is dry before operations begin.</p> <p>c. Remove pipe plug (1) from sediment strainer (2). Remove screen (3) and clean using water, cleaning solvent, or rag. Reinstall screen (3).</p> <div style="text-align: center;">  </div> <p>d. Check for missing or damaged gaskets.</p> | <p>Parts are broken or out of round.</p> <p>Holes are clogged.</p> <p>Sediment strainer is clogged or missing.</p> <p>Gaskets are missing or damaged.</p> |

OPERATOR'S PREVENTIVE MAINTENANCE CHECKS AND SERVICES (PMCS) - Continued

Table 1. Before Operation PMCS for M12A1 DED Decontaminating Apparatus - Continued.

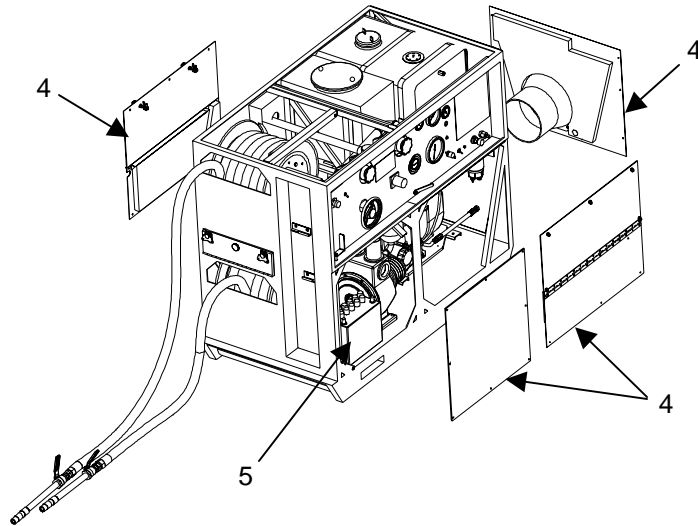

| Item No. | Interval | Man Hour | Item to be Checked/ Serviced | Procedure | Not Fully Mission Capable If: |
|----------|----------|----------|------------------------------|--|---|
| 4 | BEFORE | | Pump Unit Cover Panels | a. Remove quick release panels and inspect panels, handle assemblies, and foam sound pads for damage. Inspect panels for damage and cracks. b. Check that instruction and identification plates are legible. c. When necessary tighten hardware and connections. See that wiring and other objects do not obstruct moving parts. | Instruction and identification plates are illegible and TM is missing. |
| 5 | BEFORE | | Battery | a. See that the battery is fully charged. See that the positive and ground cables are attached properly to the battery terminals and to the engine. See that the battery is fastened tightly to the pump unit skid. b. Check electrolyte level. If electrolyte is not filled to ledge in filler opening, notify unit maintenance. c. Check that vent holes in vent caps are clear. d. Inspect frame area terminals, clamps, cables, and hold-downs for corrosion. | Battery is unserviceable or improperly attached. Electrolyte level is low. |

OPERATOR'S PREVENTIVE MAINTENANCE CHECKS AND SERVICES (PMCS) - Continued

Table 1. Before Operation PMCS for M12A1 DED Decontaminating Apparatus - Continued.

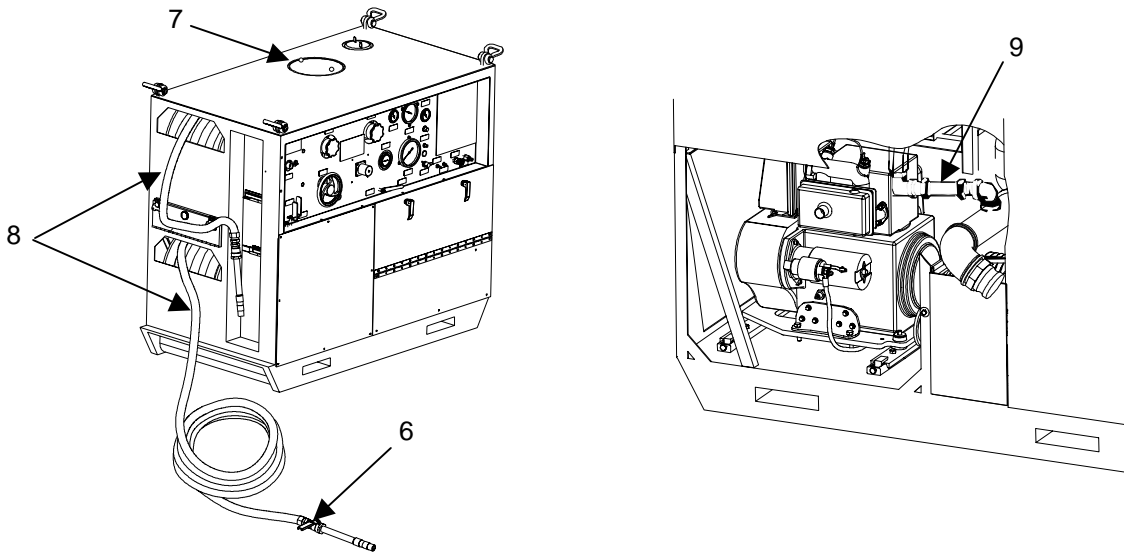

| Item No. | Interval | Man Hour | Item to be Checked/ Serviced | Procedure | Not Fully Mission Capable If: |
|----------|----------|----------|---|---|---|
| 6 | BEFORE | | Pump Unit (Cont) Gun Assembly and Slurry Nozzle Assembly | See that a gun assembly is on each of the discharge hoses. Check that the gun handle operates the valve. Close the valves. Inspect the gun assembly and slurry nozzle assembly for dirt and hardened slurry. Inspect the threaded fittings for nicks, burrs, or other damage. Inspect the gun handle for cracks, chips, twists, bends, or other damage that would interfere with efficient operation. Inspect the extension pipe and adapter for cracks, bends, holes, being out of round, or other damage that would affect operation of the gun assembly. | Both gun assemblies inoperative. |
| 7 | BEFORE | | Prime-Detergent Tank Assembly and Tank Lid | Check that there are no foreign objects or sediment in tank. Clean if necessary. Close VALVE NO. 4 PRIME on control panel. Fill tank with water and check for leaks. | Foreign objects or sediment are in tank. Tank leaks continuously. |
| 8 | BEFORE | | Discharge Hose Assemblies | Inspect discharge hoses for leaks, breaks, or other damage. | Both discharge hoses leak continuously. |
| 9 | BEFORE | | Eductor Hose Assembly | a. Inspect the eductor hose for leaks or breaks. b. Make sure hose clamps are tight. | Eductor hose leaks. |

OPERATOR'S PREVENTIVE MAINTENANCE CHECKS AND SERVICES (PMCS) - Continued

Table 1. Before Operation PMCS for M12A1 DED Decontaminating Apparatus - Continued.

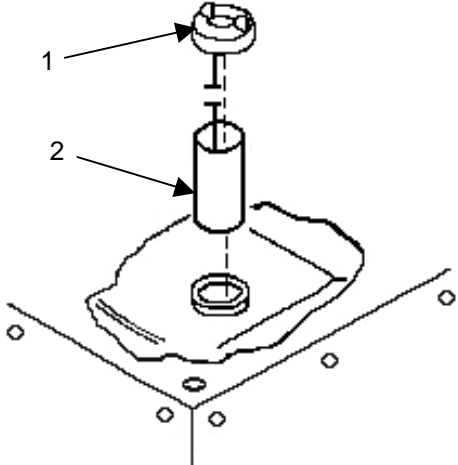
| Item No. | Interval | Man Hour | Item to be Checked/ Serviced | Procedure | Not Fully Mission Capable If: |
|----------|----------|----------|-----------------------------------|--|--|
| 10 | BEFORE | | Pump Unit (Cont) Fuel Tank | <p style="text-align: center;">WARNING</p> <p>Inspect fuel tank interior in daylight. If the fuel tank must be inspected at night, use a vapor-proof light.</p> <p>Be sure to use JP-8 or diesel fuel.</p> <p style="text-align: center;">CAUTION</p> <p>If fuel tank cap gasket is missing or unserviceable, be careful when washing pump unit to avoid getting water in fuel tank.</p> <p>a. Remove fuel tank cap (1). Inspect to see that gasket is present and serviceable. Lift out strainer (2) with screen. Clean screen. See that there are no foreign objects or sediment in tank. Replace strainer (2) with screen.</p>  | Foreign objects or sediment are in tank. |

OPERATOR'S PREVENTIVE MAINTENANCE CHECKS AND SERVICES (PMCS) - Continued

Table 1. Before Operation PMCS for M12A1 DED Decontaminating Apparatus - Continued.

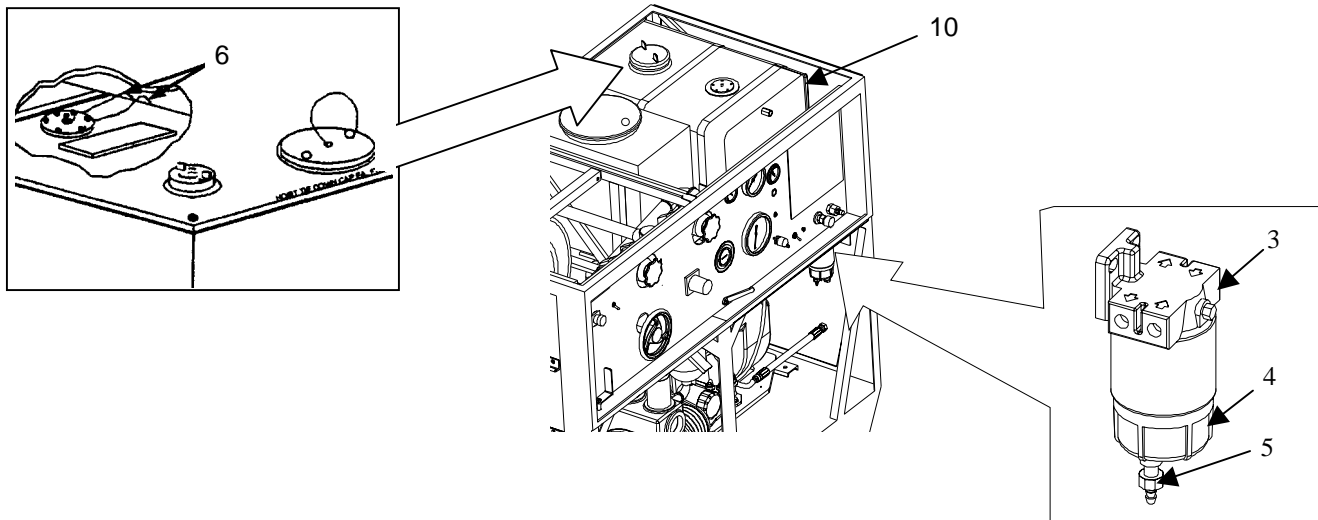

| Item No. | Interval | Man Hour | Item to be Checked/ Serviced | Procedure | Not Fully Mission Capable If: |
|----------|----------|----------|--------------------------------------|---|--|
| 10 | BEFORE | | Pump Unit (Cont) Fuel Tank (Cont) | b. Fill fuel tank with JP-8 or diesel fuel and check for leaks. c. Inspect pump unit fuel filter (3) for cracks or leaks. d. Inspect for accumulation of dirt or water in plastic bowl (4). If contaminants visible, drain fuel filter as follows: (1) Turn on fuel valve under fuel tank. (2) Position container under drain plug (5). (3) Loosen drain plug (5). Allow fuel to drain into container until contaminants are gone. (4) Tighten drain plug (5) and check for leakage. d. Check for loose/missing drain plug (5). Tighten if loose. e. Check that fuel tank is filled with JP-8 or diesel fuel. | Fuel tank leaks. Fuel filter cracked or leaking. Unable to drain contaminants from filter. Drain plug is missing. Tank is empty. |

OPERATOR'S PREVENTIVE MAINTENANCE CHECKS AND SERVICES (PMCS) - Continued

Table 1. Before Operation PMCS for M12A1 DED Decontaminating Apparatus - Continued.

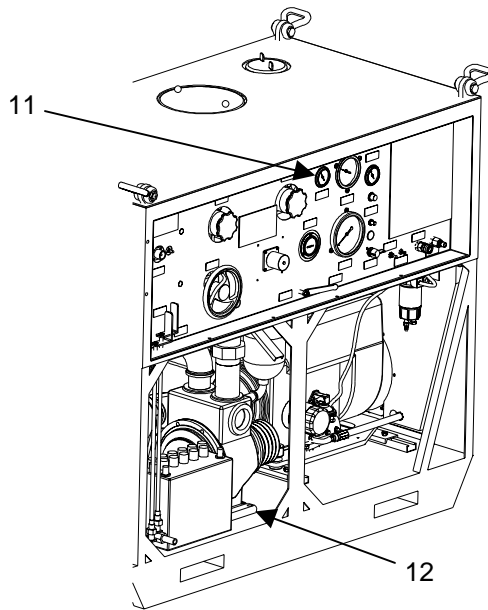

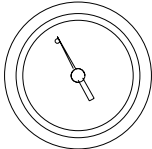
| Item No. | Interval | Man Hour | Item to be Checked/ Serviced | Procedure | Not Fully Mission Capable If: |
|----------|----------|----------|--|---|--|
| 11 | BEFORE | | Pump Unit (Cont) FUEL INDICATOR | <p style="text-align: center;">NOTE</p> <p>FUEL INDICATOR may not return to zero when system is off. Visually check fuel tank to confirm fuel quantity.</p> <p>Check that FUEL INDICATOR registers when IGNITION switch is turned to the RUN position.</p> <div style="text-align: center;">  <p>FUEL INDICATOR</p> </div> | |
| 12 | BEFORE | | Pump Unit Subassembly | Check that centrifugal pump support is not broken, cracked, or dented. | Centrifugal pump supports broken or missing. |

OPERATOR'S PREVENTIVE MAINTENANCE CHECKS AND SERVICES (PMCS) - Continued

Table 1. Before Operation PMCS for M12A1 DED Decontaminating Apparatus - Continued.

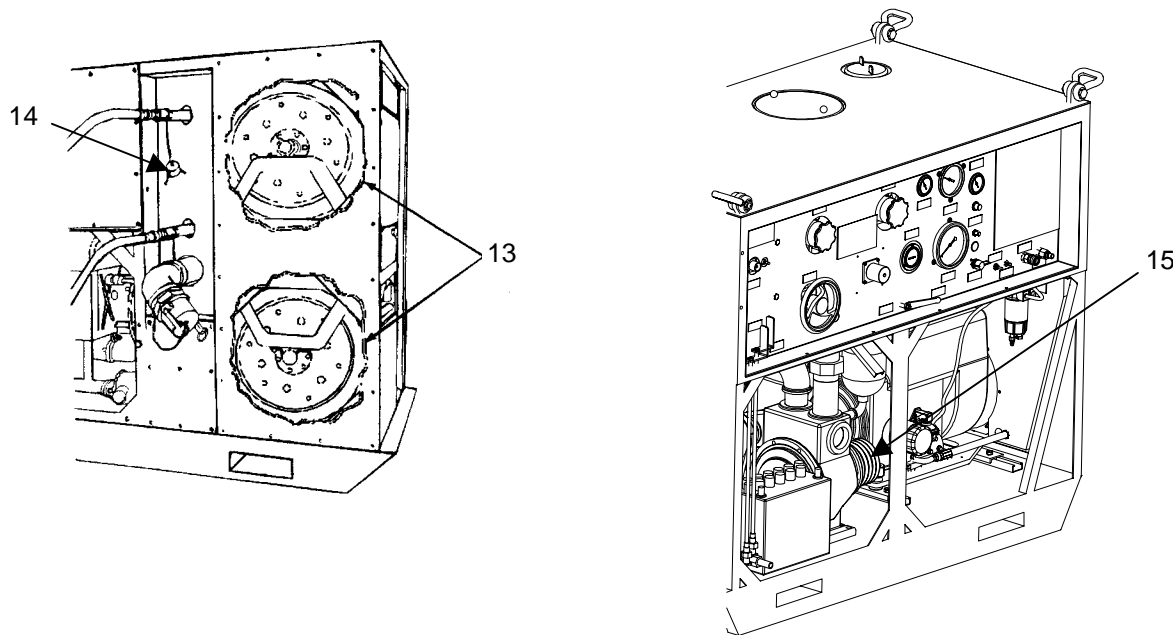

| Item No. | Interval | Man Hour | Item to be Checked/ Serviced | Procedure | Not Fully Mission Capable If: |
|----------|----------|----------|------------------------------|---|--|
| 13 | BEFORE | | Hose Reels | Inspect that the crank handle inserts easily and turns the reels smoothly. | |
| 14 | BEFORE | | Connector Panel | Check that the dust caps each have a seal installed inside the cap. | Seal is missing. |
| 15 | BEFORE | | Drive Belts | Check pump and alternator drive belts for wear, breaks, or fraying. Check for proper tension: 5-7 lb at 3/8-inch deflection (WP 0023 00). | One or more belts broken or missing. Tension incorrect. |

OPERATOR'S PREVENTIVE MAINTENANCE CHECKS AND SERVICES (PMCS) - Continued

Table 1. Before Operation PMCS for M12A1 DED Decontaminating Apparatus - Continued.

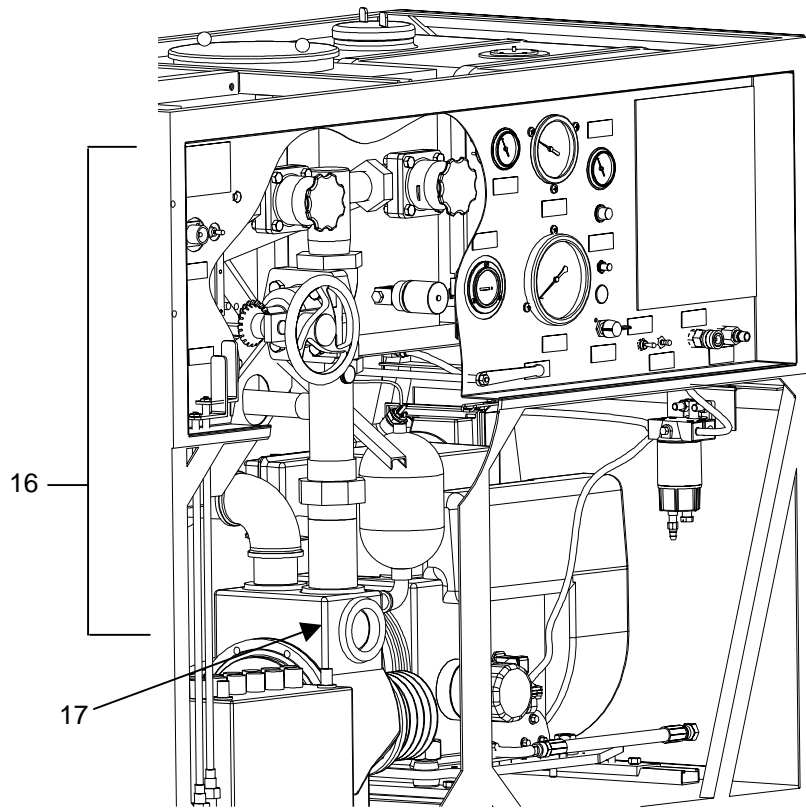

| Item No. | Interval | Man Hour | Item to be Checked/ Serviced | Procedure | Not Fully Mission Capable If: |
|----------|----------|----------|------------------------------|---|--|
| 16 | BEFORE | | Plumbing Assembly | Inspect piping for cracks, corrosion, and evidence of leaks. | Piping leaks continuously. |
| 17 | BEFORE | | Centrifugal Pump | <p>a. Inspect the pump housing for cracks, corrosion, and leaks.</p> <p>b. Check that the pump is tightly mounted to the skid base and that all piping connections do not leak.</p> <p>c. Lubricate pump according to Lubrication Instructions (WP 0020 00) or as needed.</p> | <p>Pump housing leaks continuously.</p> <p>Piping connections leak continuously, or pump is not mounted tightly.</p> |

OPERATOR'S PREVENTIVE MAINTENANCE CHECKS AND SERVICES (PMCS) - Continued

Table 1. Before Operation PMCS for M12A1 DED Decontaminating Apparatus - Continued.

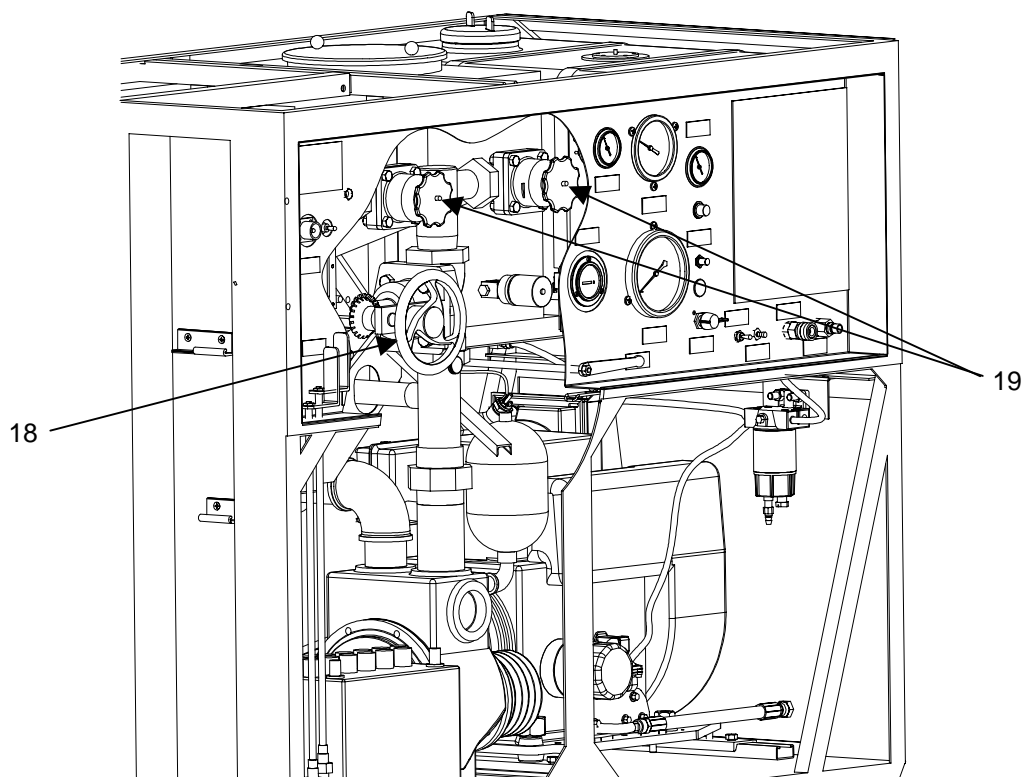

| Item No. | Interval | Man Hour | Item to be Checked/ Serviced | Procedure | Not Fully Mission Capable If: |
|----------|----------|----------|---|---|---|
| 18 | BEFORE | | Pump Unit Subassembly VALVE NO. 1 MANIFOLD | a. Check that mounting hardware is tight. Inspect valve and associated piping for leaks, or rust. Turn valve handle and check that valve turns smoothly and easily. b. Lubricate valve stem according to Lubrication Instructions (WP 0020 00) or as needed. | Valve does not open or close completely, or valve leaks continuously. |
| 19 | BEFORE | | VALVE NO. 2 LOWER REEL and VALVE NO. 3 UPPER REEL | a. Check that the valves turn smoothly. b. Lubricate valve stems according to Lubrication Instructions (WP 0020 00) or as needed. c. Inspect the valves for evidence of leaks, corrosion, or breaks. | Valve does not open or close completely. Valves leak continuously. |

OPERATOR'S PREVENTIVE MAINTENANCE CHECKS AND SERVICES (PMCS) - Continued

Table 1. Before Operation PMCS for M12A1 DED Decontaminating Apparatus - Continued.

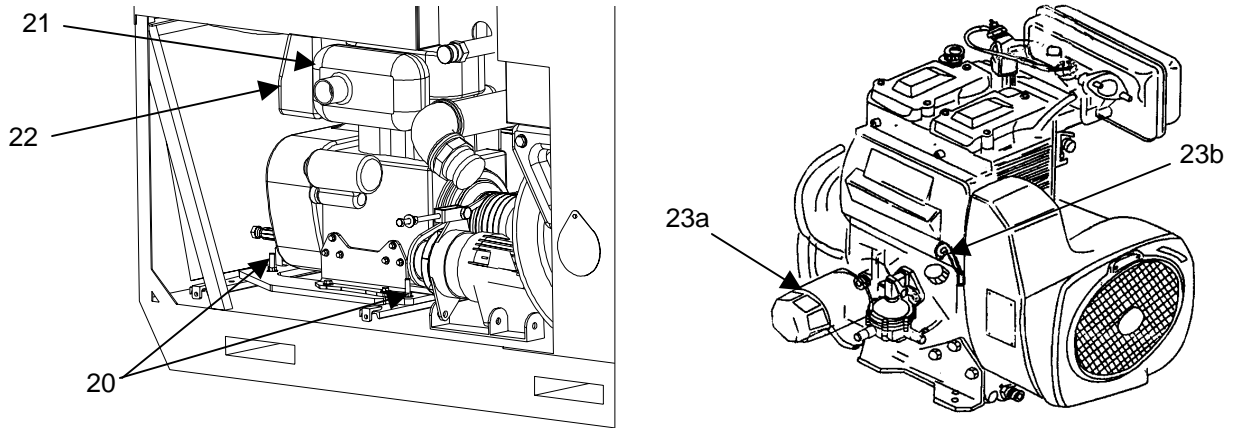

| Item No. | Interval | Man Hour | Item to be Checked/ Serviced | Procedure | Not Fully Mission Capable If: |
|----------|----------|----------|-------------------------------------|--|--|
| 20 | BEFORE | | Pump Unit (Cont) Engine Assembly | Make sure that engine vibration mounts, nuts, and bolts are present and in good condition. If loose, notify Unit Maintenance. | Engine mounts are missing. Bolts loose or missing. |
| 21 | BEFORE | | Muffler | Check muffler for loose or missing mounting nuts. If loose, tighten. | Mounting is damaged or mounting nuts are missing. |
| 22 | BEFORE | | Air Filter Assembly | a. Check that latches on air filter assembly are properly engaged. b. Check air filter element is not plugged or dirty (WP 0024 00). Replace if needed. | Filter element is missing or clogged. |
| 23 | BEFORE | | Engine Oil and Engine Oil Filter | a. Check oil filter for leaks or damage. b. Pull up the oil dipstick and check engine oil level (oil level should be between tic marks). Add oil if necessary (Page 0028 00-2, item 16 or 17). Recheck oil level until oil is between tic marks. Do not overfill. | Class III leak. |

OPERATOR'S PREVENTIVE MAINTENANCE CHECKS AND SERVICES (PMCS) - Continued

Table 1. Before Operation PMCS for M12A1 DED Decontaminating Apparatus - Continued.

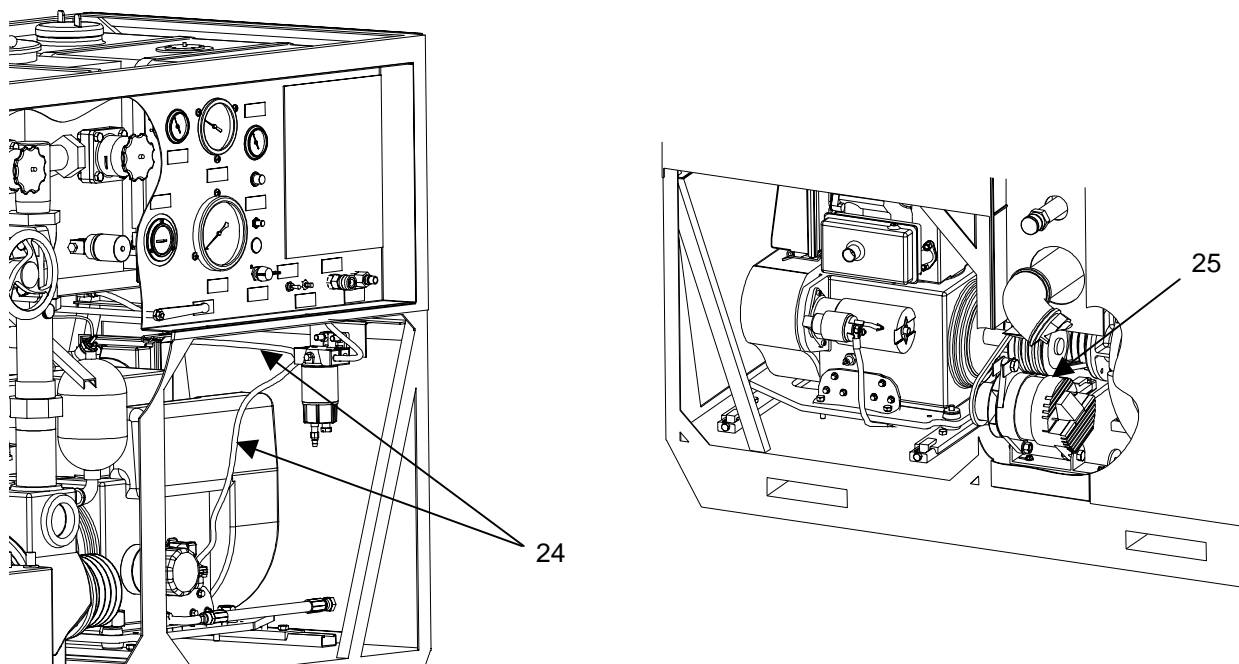

| Item No. | Interval | Man Hour | Item to be Checked/ Serviced | Procedure | Not Fully Mission Capable If: |
|----------|----------|----------|-----------------------------------|---|---|
| 24 | BEFORE | | Pump Unit (Cont) Fuel Hose | <p>NOTE</p> <p>Fuel hose is black rubber hose, size 1/4". Fuel delivery hose is from fuel tank to fuel filter/water separator then to engine pump.</p> <p>Check fuel hoses for cuts, tears, leaks, and damage or loose fittings. Tighten fittings as required.</p> | Any fuel leak. |
| 25 | BEFORE | | Alternator Assembly | <p>a. See that no parts are missing and that hardware fastening the assembly to the base is not loose or missing.</p> <p>b. Check that the electrical cables are fastened at both terminals.</p> <p>c. Check that pulley is not bent or cracked.</p> | <p>Cables are damaged or missing.</p> <p>Pulley is bent or cracked.</p> |

OPERATOR'S PREVENTIVE MAINTENANCE CHECKS AND SERVICES (PMCS) - Continued

Table 1. Before Operation PMCS for M12A1 DED Decontaminating Apparatus - Continued.

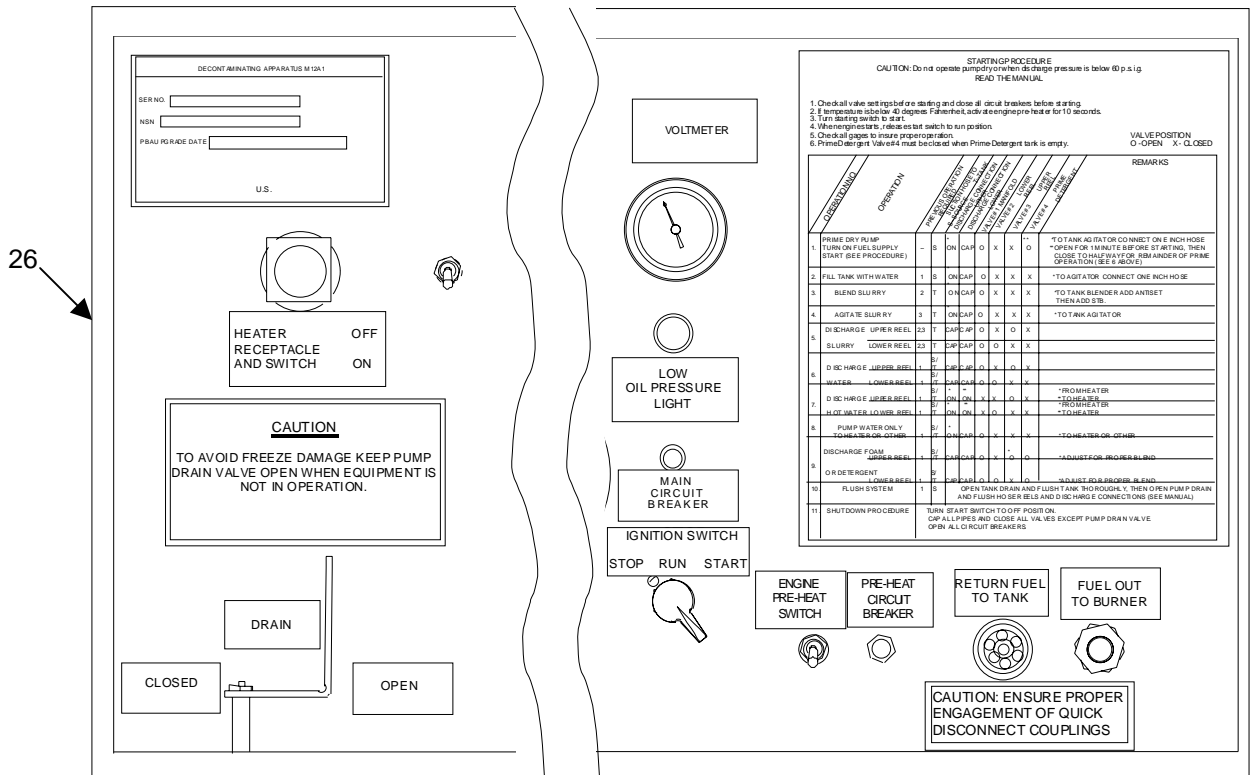

| Item No. | Interval | Man Hour | Item to be Checked/ Serviced | Procedure | Not Fully Mission Capable If: |
|----------|----------|----------|--|--|-------------------------------|
| 26 | BEFORE | | Pump Unit (Cont) Control Panel Assembly | <p>a. The control panel can be inspected without having to remove it from the pump unit assembly. Wipe all switches and gages with cloth to remove accumulated dirt. Clean the control panel with a cloth (Page 0028 00-3, item 21) and water. Inspect switches for loose parts or damaged leads. Inspect gages for cracked dials.</p> <p>b. Inspect that HEATER RECEPTACLE AND SWITCH is securely fastened to the control panel.</p> <p>c. Turn IGNITION switch to RUN but do not start engine. LOW OIL PRESSURE LIGHT should illuminate.</p> | Light does not illuminate. |

OPERATOR'S PREVENTIVE MAINTENANCE CHECKS AND SERVICES (PMCS) - Continued

Table 1. Before Operation PMCS for M12A1 DED Decontaminating Apparatus - Continued.

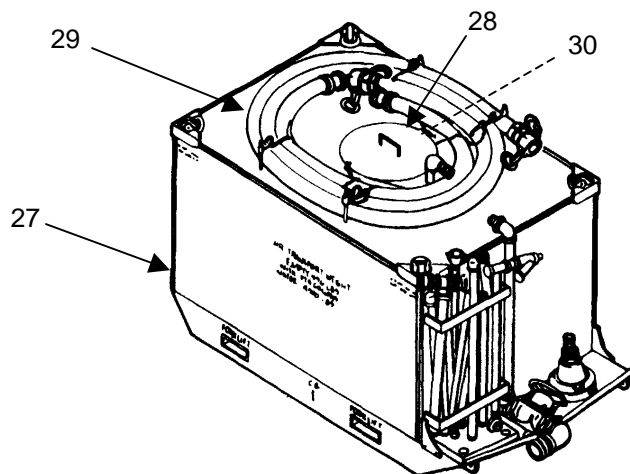

| Item No. | Interval | Man Hour | Item to be Checked/ Serviced | Procedure | Not Fully Mission Capable If: |
|----------|----------|----------|------------------------------|---|---|
| 27 | BEFORE | | Tank Unit | a. Check that tank is fastened to skid base assembly. b. Check that suction hose is stowed properly on top of the tank unit. c. Inspect for broken welds, leaks, obstructions, loose pipe fittings, and missing parts. | Tank leaks continuously. |
| 28 | BEFORE | | Hopper Assembly | a. Inspect the hopper assembly for broken welds and evidence of leaks. b. Check that quick disconnect on blender pipe is not out of round or loose. c. Check that dry slurry has not accumulated on inside screen. d. Check that the blender hose is coiled inside the hopper when not in use. | Quick disconnect is out of round or loose. Screen is completely blocked. |
| 29 | BEFORE | | Suction Hose Assembly | Check that quick release couplings have gaskets installed. Check for leaks, breaks, or other damage. | Gaskets are missing. Hose leaks continuously. |
| 30 | BEFORE | | Blender Hose | Check that quick release couplings have gaskets installed. Check for leaks, breaks, or other damage. | Gaskets are missing. Hose leaks continuously. |

OPERATOR'S PREVENTIVE MAINTENANCE CHECKS AND SERVICES (PMCS) - Continued

Table 1. Before Operation PMCS for M12A1 DED Decontaminating Apparatus - Continued.

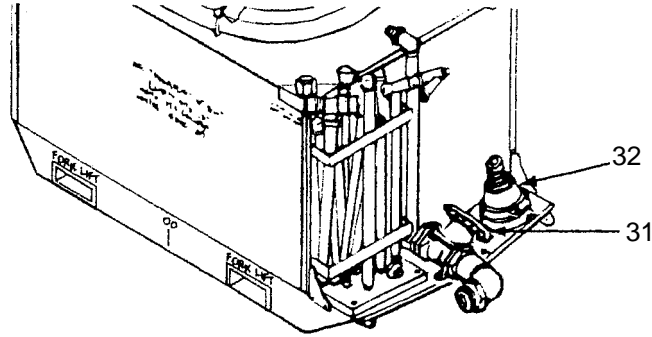

| Item No. | Interval | Man Hour | Item to be Checked/ Serviced | Procedure | Not Fully Mission Capable If: |
|----------|----------|----------|--------------------------------------|--|---|
| 31 | BEFORE | | Tank Unit (Cont) Tank Drain Valve | <p style="text-align: center;">WARNING</p> <p style="text-align: center;">When operating tank drain valve, be careful not to catch fingers in slot.</p> <p>a. Check that the tank drain valve turns smoothly and that stem has been lubricated.</p> <p>b. Lubricate according to Lubrication Instructions (WP 0020 00).</p> <p>c. Inspect the tank drain valve for evidence of leaks, corrosion, or breaks.</p> <p>d. Check that all mounting hardware is tight and secure.</p> | Drain valve does not turn or open and close completely. |
| 32 | BEFORE | | Foot Valve | <p>a. Check the foot valve for missing parts.</p> <p>b. Check for breaks or cracks.</p> <p>c. Make sure that foot valve is securely mounted on tank skid base.</p> | Parts are missing. |

OPERATOR'S PREVENTIVE MAINTENANCE CHECKS AND SERVICES (PMCS) - Continued

Table 1. Before Operation PMCS for M12A1 DED Decontaminating Apparatus - Continued.

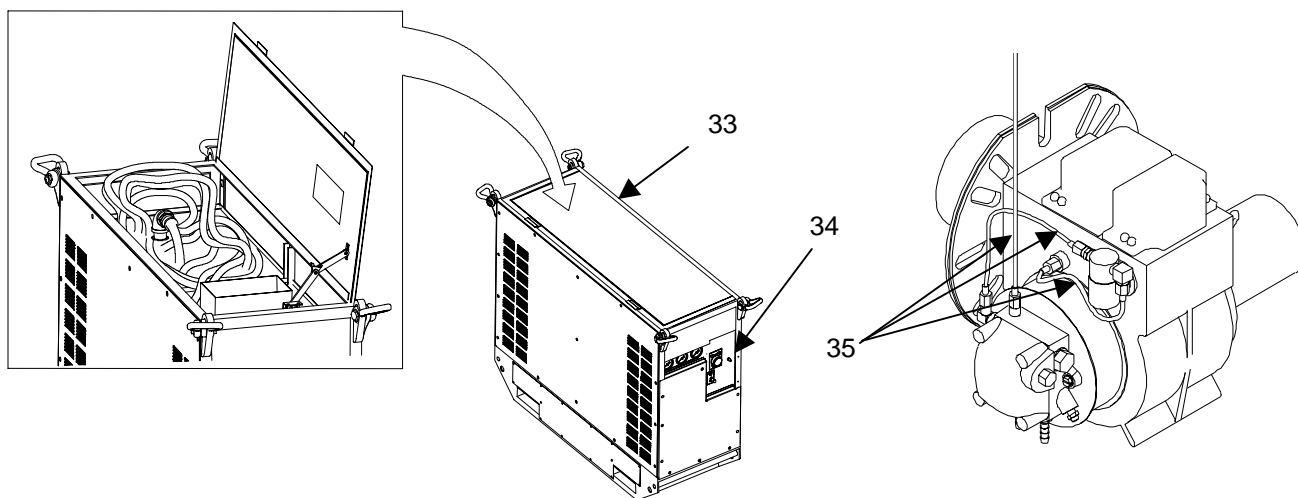

| Item No. | Interval | Man Hour | Item to be Checked/ Serviced | Procedure | Not Fully Mission Capable If: |
|----------|----------|----------|------------------------------|---|---|
| 33 | BEFORE | | Water Heater | a. Inspect to see that all cables and hoses are properly stored in storage compartment. b. Inspect for loose or missing nuts or bolts. Tighten hardware when necessary. c. Check that all decals, stencils, and identification plates are legible. d. Check that electrical wires are properly secured above boiler and not touching boiler. | Identification plates are missing and TM is missing. Electrical wire clamp is missing. |
| 34 | BEFORE | | Control Box Assembly | a. Inspect control box for broken, missing, or loose parts. Tighten as necessary. b. Inspect to see that the glass in the fuel, water, and temperature gages is not broken. c. Check that controls and instruments are in good condition. | |
| 35 | BEFORE | | All Fabricated Lines | Check all the fabricated lines for signs of kinks and sharp bends. | Lines are kinked. |

OPERATOR'S PREVENTIVE MAINTENANCE CHECKS AND SERVICES (PMCS) - Continued

Table 1. Before Operation PMCS for M12A1 DED Decontaminating Apparatus - Continued.

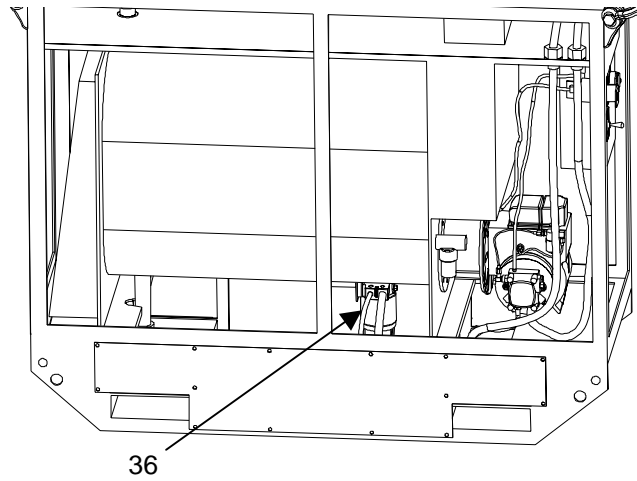

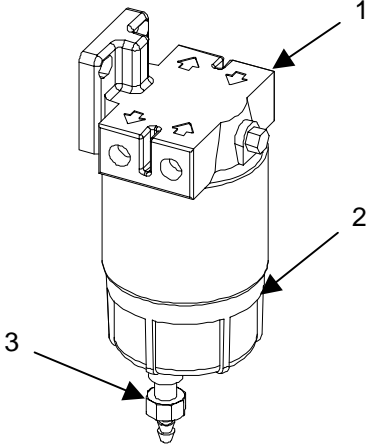
| Item No. | Interval | Man Hour | Item to be Checked/ Serviced | Procedure | Not Fully Mission Capable If: |
|----------|----------|----------|------------------------------------|--|--|
| 36 | BEFORE | | Water Heater (Cont) Fuel Filter | <p>a. Inspect burner fuel filter (1) for cracks or leaks.</p> <p>b. Inspect for accumulation of dirt or water in plastic bowl (2). If contaminants visible, drain fuel filter as follows:</p> <ol style="list-style-type: none"> (1) Position container under drain plug (3). (2) Loosen drain plug (3). Allow fuel to drain into container until contaminants are gone. (3) Tighten drain plug (3) and check for leakage. <p>c. Check for loose/missing drain plug (3). Tighten if loose.</p>  | <p>Fuel filter cracked or leaking.</p> <p>Unable to drain contaminants from filter.</p> <p>Drain plug missing.</p> |

OPERATOR'S PREVENTIVE MAINTENANCE CHECKS AND SERVICES (PMCS) - Continued

Table 1. Before Operation PMCS for M12A1 DED Decontaminating Apparatus - Continued.

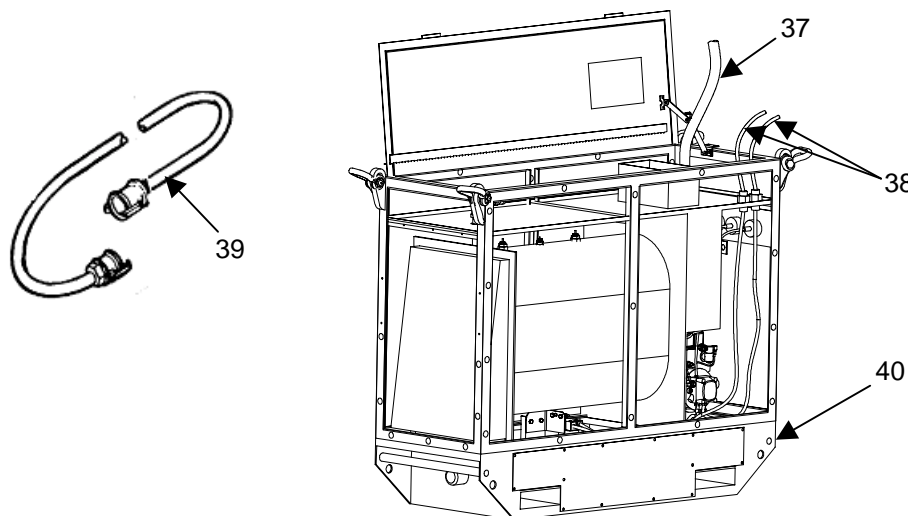

| Item No. | Interval | Man Hour | Item to be Checked/ Serviced | Procedure | Not Fully Mission Capable If: |
|----------|----------|----------|------------------------------------|---|--|
| 37 | BEFORE | | Water Heater (Cont) Power Cable | a. Check for cracks, deterioration, bare or frayed wire, and kinks. b. Check for dirty or damaged plug connector. | Badly worn cable. Unworkable plug connector. |
| 38 | BEFORE | | Fuel Hoses | a. Check for cuts or breaks. Check fuel hose connectors for ease of operation. b. Check that connectors are clean and free of foreign matter. | Unserviceable hose or connectors. |
| 39 | BEFORE | | Water Hose | a. Check that all connections are tight. b. Inspect for cracks and broken or missing parts or gaskets. c. Check that quick disconnect couplings are properly installed and gaskets are present. | Couplings are missing parts. Gaskets are missing. |
| 40 | BEFORE | | Skid Assembly | Inspect for missing panels or broken/missing water coupling. | Water coupling is broken or missing. |

OPERATOR'S PREVENTIVE MAINTENANCE CHECKS AND SERVICES (PMCS) - Continued

Table 1. Before Operation PMCS for M12A1 DED Decontaminating Apparatus - Continued.

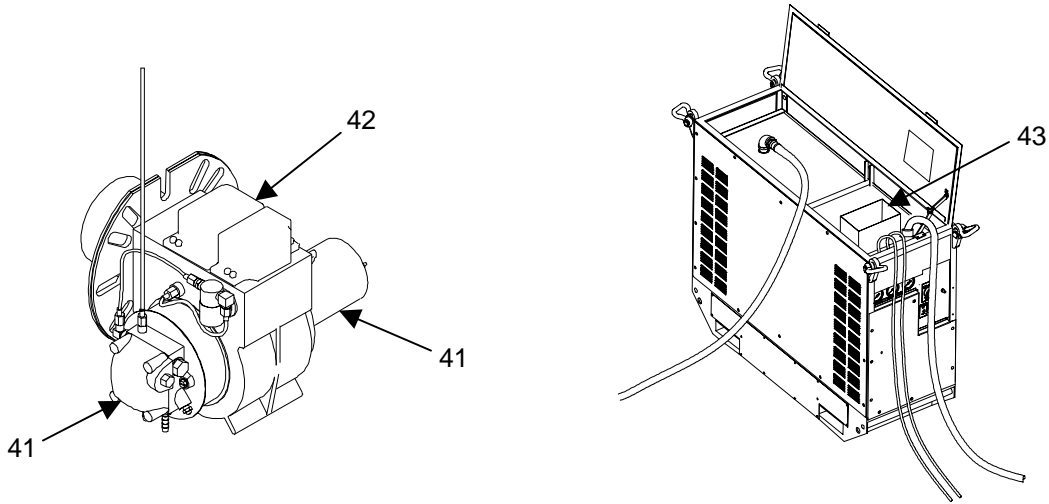

| Item No. | Interval | Man Hour | Item to be Checked/ Serviced | Procedure | Not Fully Mission Capable If: |
|----------|----------|----------|---|--|---|
| 41 | BEFORE | | Water Heater (Cont) Fuel Pump and Blower Motor | See that all mounting hardware is present and secure. | |
| 42 | BEFORE | | Burner Assembly | a. Check burner assembly for fuel leaks, damaged fuel lines, and electrical wiring. b. Check under boiler for loose fittings. c. Connect power cable and fuel hoses to pump unit. Turn IGNITION switch to RUN, but do not start engine. Set HEATER ON/OFF switch to ON, with THERMOSTAT OFF. Check that fuel pump/blower motor is running. Check that fuel pressure is 150 psi and steady. | Any fuel leaks or loose or broken wires. No fuel pressure or fuel pressure is fluctuating. |
| 43 | BEFORE | | Low Pressure Boiler Assembly | Check to see that the exhaust stack screen is not broken, loose, missing, or full of soot. | Screen is broken or missing. |

END OF WORK PACKAGE

**OPERATOR
M12A1 DIESEL ENGINE DRIVEN DECONTAMINATION APPARATUS
NSN 4230-01-502-7224
DURING OPERATION PREVENTIVE MAINTENANCE CHECKS AND SERVICES (PMCS)**

INITIAL SETUP:

Materials/Parts

Rag, Wiping (Page 0028 00-3, item 21)

OPERATOR'S PREVENTIVE MAINTENANCE CHECKS AND SERVICES (PMCS)

Table 1. During Operation PMCS for M12A1 DED Decontaminating Apparatus.

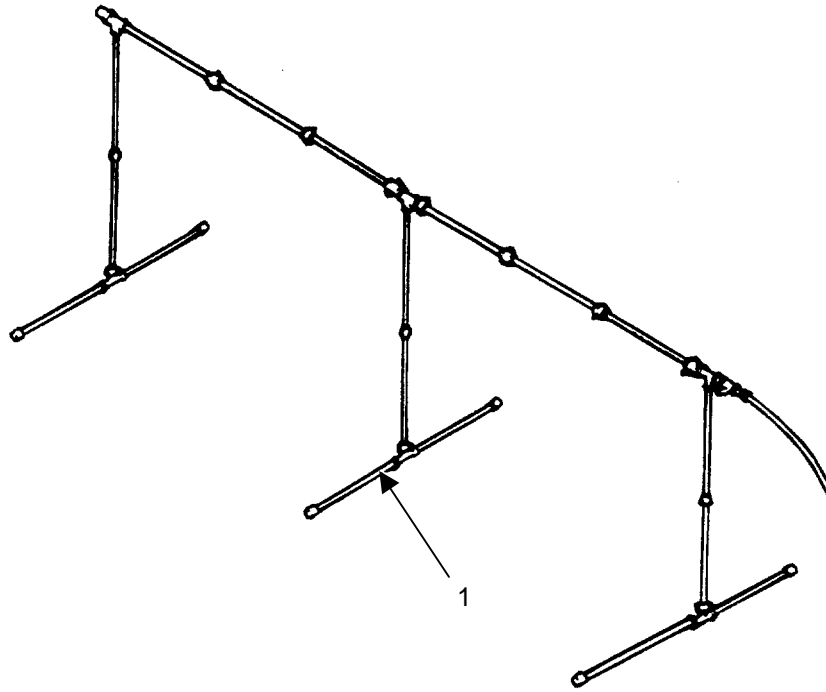

| Item No. | Interval | Man Hour | Item to be Checked/ Serviced | Procedure | Not Fully Mission Capable If: |
|----------|----------|----------|------------------------------|---|-------------------------------|
| 1 | DURING | | Personnel Shower Assembly | Make sure the shower outlet holes in the six pieces of pipe are open. | Holes are clogged. |

OPERATOR'S PREVENTIVE MAINTENANCE CHECKS AND SERVICES (PMCS) - Continued

Table 1. During Operation PMCS for M12A1 DED Decontaminating Apparatus - Continued.

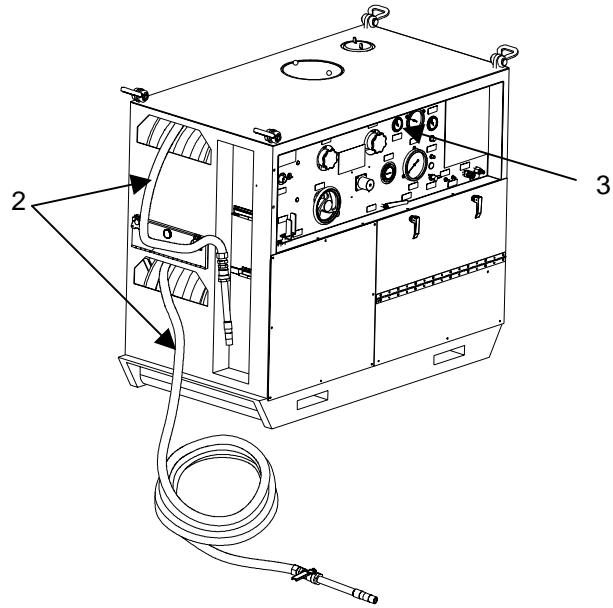

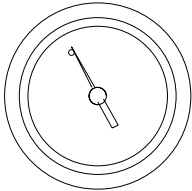
| Item No. | Interval | Man Hour | Item to be Checked/ Serviced | Procedure | Not Fully Mission Capable If: |
|----------|----------|----------|--|--|------------------------------------|
| 2 | DURING | | Pump Unit Discharge Hose Assemblies | Inspect discharge hoses for leaks, breaks, or other damage. | Discharge hose leaks continuously. |
| 3 | DURING | | Fuel Tank | Check that FUEL INDICATOR registers when ignition switch is turned to the RUN position. <div style="text-align: center; margin-top: 20px;">  <div style="border: 1px solid black; padding: 5px; width: fit-content; margin: 0 auto;">FUEL INDICATOR</div> </div> | |

OPERATOR'S PREVENTIVE MAINTENANCE CHECKS AND SERVICES (PMCS) - Continued

Table 1. During Operation PMCS for M12A1 DED Decontaminating Apparatus - Continued.

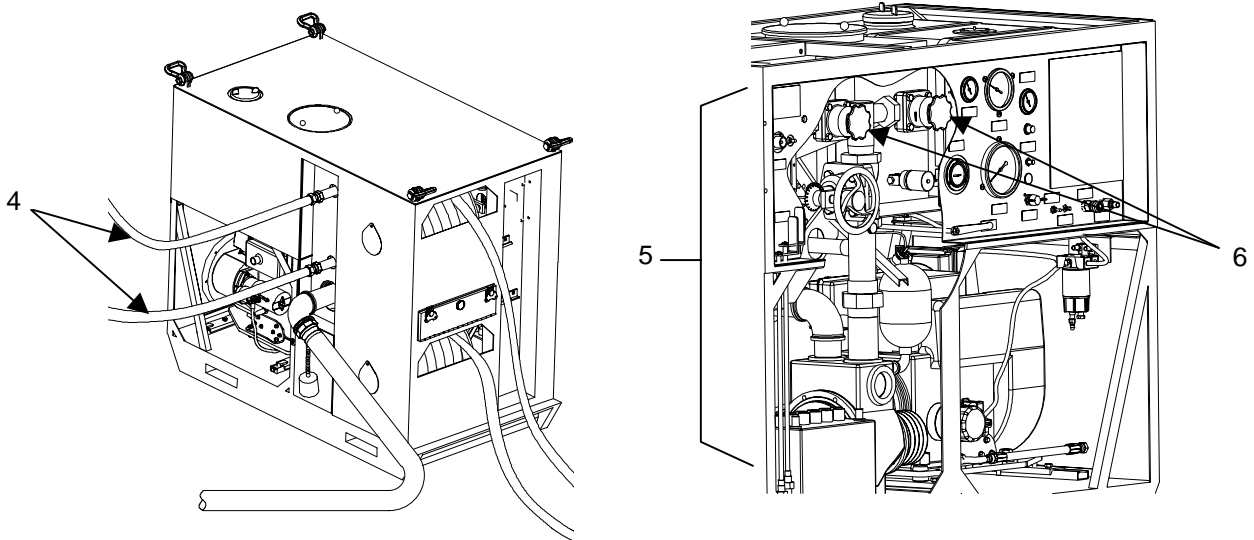

| Item No. | Interval | Man Hour | Item to be Checked/ Serviced | Procedure | Not Fully Mission Capable If: |
|----------|----------|----------|---|---|--|
| 4 | DURING | | Pump Unit (Cont) Outlet Hoses | Check hoses and couplings for leaks. | Hoses and couplings leak continuously. |
| 5 | DURING | | Plumbing Assembly | Inspect piping for cracks, corrosion, and evidence of leaks. | Piping leaks continuously. |
| 6 | DURING | | VALVE NO. 2 LOWER REEL and VALVE NO. 3 UPPER REEL | Inspect the valves for evidence of leaks, corrosion, or breaks. | Valves leak continuously. |

OPERATOR'S PREVENTIVE MAINTENANCE CHECKS AND SERVICES (PMCS) - Continued

Table 1. During Operation PMCS for M12A1 DED Decontaminating Apparatus - Continued.

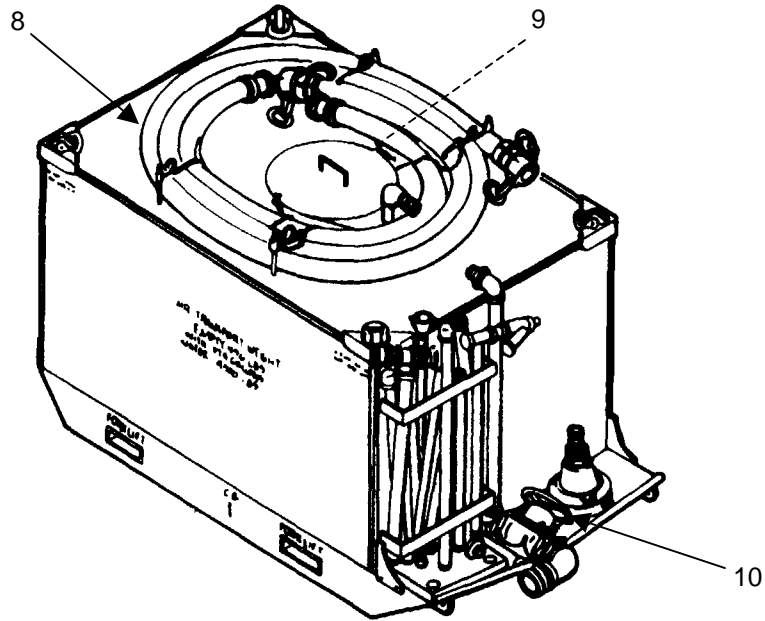

| Item No. | Interval | Man Hour | Item to be Checked/ Serviced | Procedure | Not Fully Mission Capable If: |
|----------|----------|----------|------------------------------------|---|-------------------------------|
| 8 | DURING | | Tank Unit Suction Hose Assembly | Inspect the suction hose assembly for leaks or breaks. | Hose leaks continuously. |
| 9 | DURING | | Blender Hose | Inspect the blender hose assembly for leaks or breaks. | Hose leaks continuously. |
| 10 | DURING | | Tank Drain Valve | Inspect the tank drain valve for evidence of leaks, corrosion, or breaks. | |

OPERATOR'S PREVENTIVE MAINTENANCE CHECKS AND SERVICES (PMCS) - Continued

Table 1. During Operation PMCS for M12A1 DED Decontaminating Apparatus - Continued.

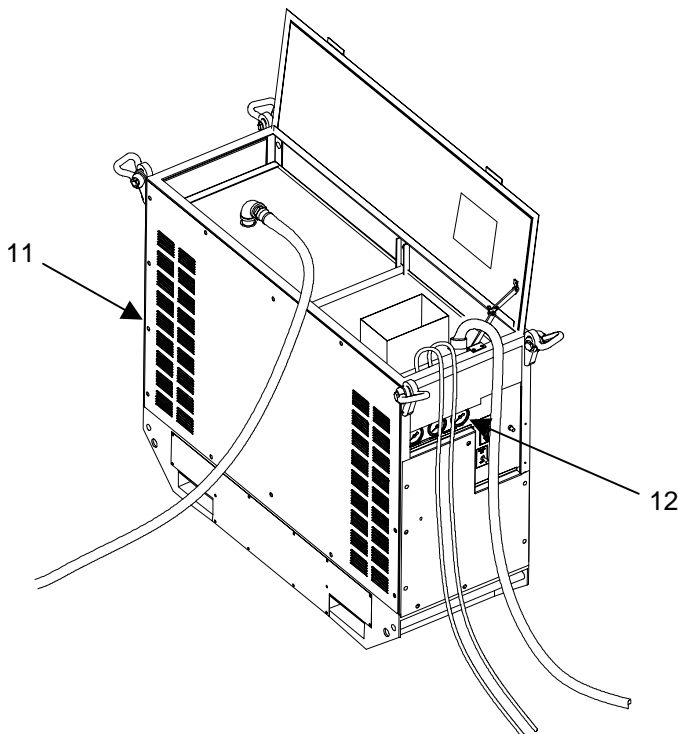

| Item No. | Interval | Man Hour | Item to be Checked/ Serviced | Procedure | Not Fully Mission Capable If: |
|----------|----------|----------|------------------------------|--|---|
| 11 | DURING | | Water Heater | While the water heater is operating, inspect for evidence of steam leaks. | Steam is leaking. |
| 12 | DURING | | Control Box Assembly | See that gages work and are reading correctly: WATER PRESSURE Gage: 60-120 psi. FUEL PRESSURE Gage: 150 psi WATER TEMPERATURE Gage: 40°F - 190°F. | WATER PRESSURE gage is not working. FUEL PRESSURE gage not working. WATER TEMPERATURE gage not working. |

OPERATOR'S PREVENTIVE MAINTENANCE CHECKS AND SERVICES (PMCS) - Continued

Table 1. During Operation PMCS for M12A1 DED Decontaminating Apparatus - Continued.

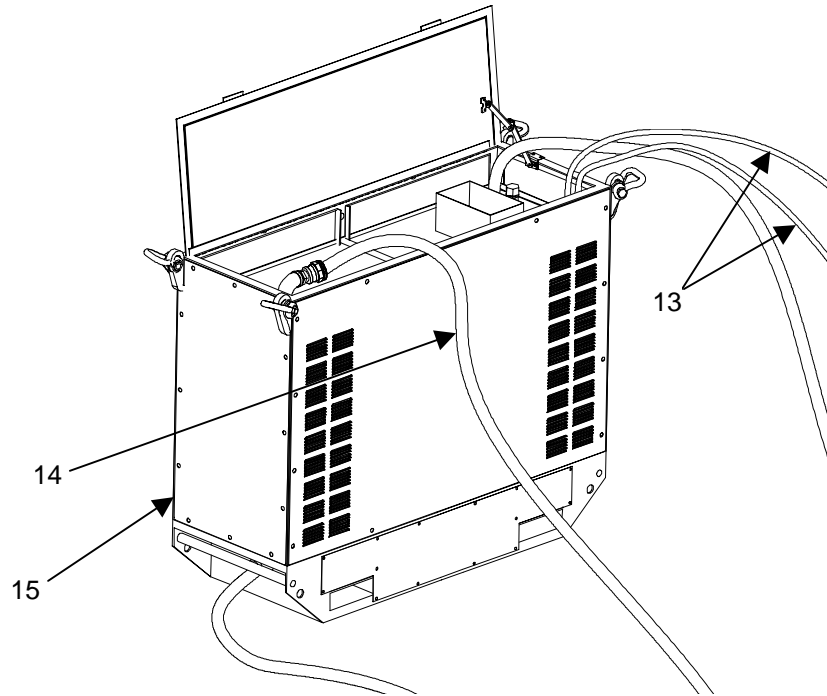

| Item No. | Interval | Man Hour | Item to be Checked/ Serviced | Procedure | Not Fully Mission Capable If: |
|----------|----------|----------|------------------------------|---|--|
| | | | Water Heater (Cont) | <p>WARNING</p> <p>Be sure that fuel hoses are not draped over exhaust stack. Failure to observe this warning could cause personnel injury.</p> | |
| 13 | DURING | | Fuel Hoses | Check for major leaks from hoses and connectors. | Hoses or connectors leak. |
| 14 | DURING | | Water Hose | Inspect for leaks. | Water hose leaks continuously. |
| 15 | DURING | | Low Pressure Boiler Assembly | Inspect for leaks around outside of the water heater unit. | Leaks around outside of water heater unit. |

END OF WORK PACKAGE

**OPERATOR
M12A1 DIESEL ENGINE DRIVEN DECONTAMINATION APPARATUS
NSN 4230-01-502-7224
AFTER OPERATION PREVENTIVE MAINTENANCE CHECKS AND SERVICES (PMCS)**

INITIAL SETUP:

Materials/Parts

- Wire Brush (Page 0028 00-1, item 5)
- Lubricating Oil (Page 0028 00-2, item 16 or 17)
- Polyurethane Coating (Green 383) (Page 0028 00-3, item 20)

References

- WP 0020 00

OPERATOR'S PREVENTIVE MAINTENANCE CHECKS AND SERVICES (PMCS)

Table 1. After Operation PMCS for M12A1 DED Decontaminating Apparatus.

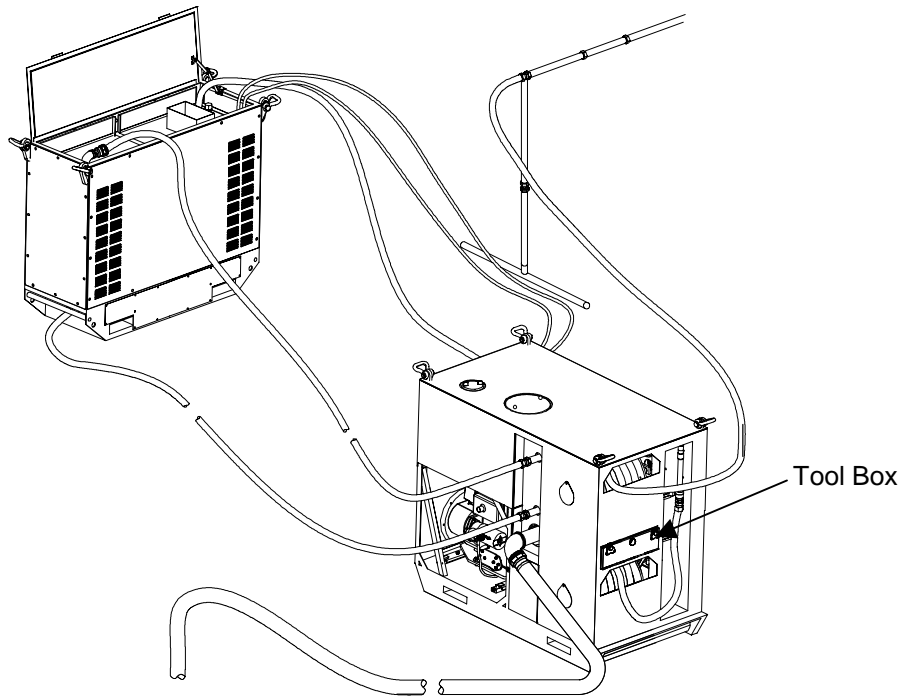

| Item No. | Interval | Man Hour | Item to be Checked/ Serviced | Procedure | Not Fully Mission Capable If: |
|----------|----------|----------|------------------------------|--|--|
| 1 | AFTER | | M12A1 DED Decon Apparatus | a. Check all hoses for cuts, breaks, cracks, missing parts or gaskets. b. Check that all on-board tools and spare parts are in tool box between the pump unit upper and lower hose reels. | Both discharge hoses are damaged. Suction hose is damaged. Fuel hose is leaking. |

OPERATOR'S PREVENTIVE MAINTENANCE CHECKS AND SERVICES (PMCS)

Table 1. After Operation PMCS for M12A1 DED Decontaminating Apparatus.

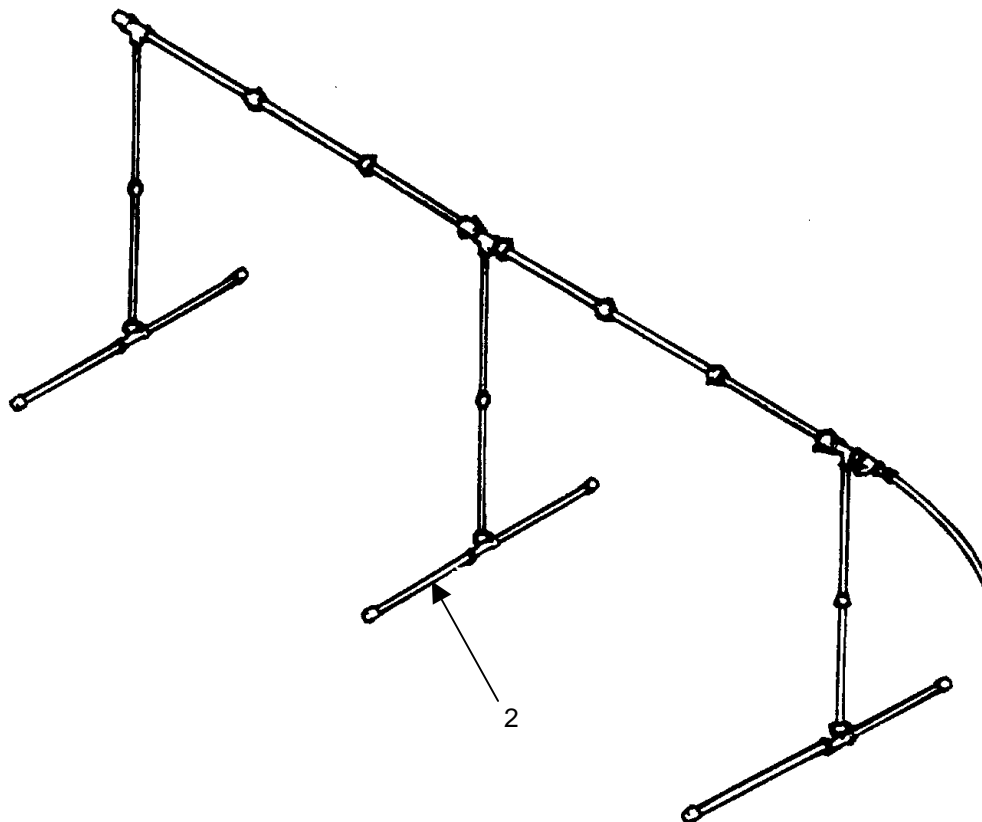

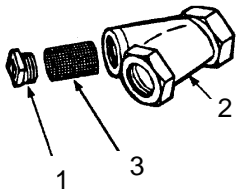
| Item No. | Interval | Man Hour | Item to be Checked/ Serviced | Procedure | Not Fully Mission Capable If: |
|----------|----------|----------|------------------------------|---|-------------------------------|
| 2 | AFTER | | Personnel Shower Assembly | Remove pipe plug (1) from sediment strainer (2). Remove, clean, and replace screen (3).  | Sediment strainer is clogged. |

OPERATOR'S PREVENTIVE MAINTENANCE CHECKS AND SERVICES (PMCS)

Table 1. After Operation PMCS for M12A1 DED Decontaminating Apparatus.

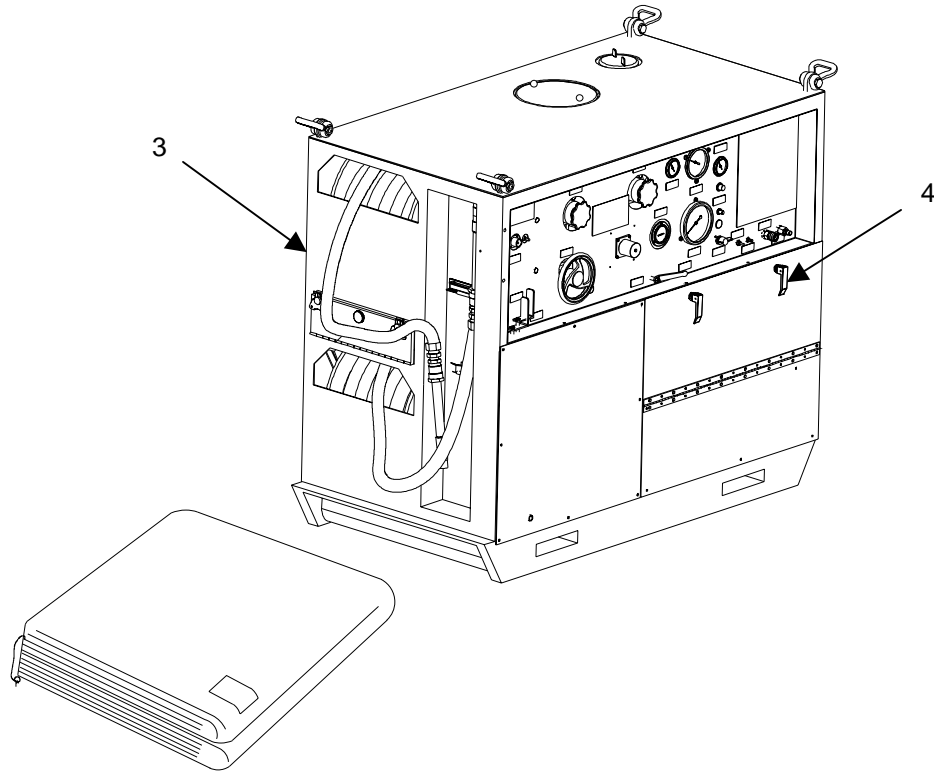

| Item No. | Interval | Man Hour | Item to be Checked/ Serviced | Procedure | Not Fully Mission Capable If: |
|----------|----------|----------|------------------------------|--|-------------------------------|
| 3 | AFTER | | Pump Unit | a. Inspect pump unit surfaces for cracks, dents, damage, and deformation. (1) Clean the exterior of the pump unit with hot, soapy water then rinse with clear water. (2) Lubricate according to Lubrication Instructions (WP 0020 00). b. Inspect canvas cover to see that all buckles, snaps, and straps are in good condition and not corroded or damaged. If cover is unserviceable and needs to be replaced, notify Unit Maintenance. | |
| 4 | AFTER | | Cover Panels | Make sure the camlock fasteners securely lock the panels to the pump unit. | |

OPERATOR'S PREVENTIVE MAINTENANCE CHECKS AND SERVICES (PMCS)

Table 1. After Operation PMCS for M12A1 DED Decontaminating Apparatus.

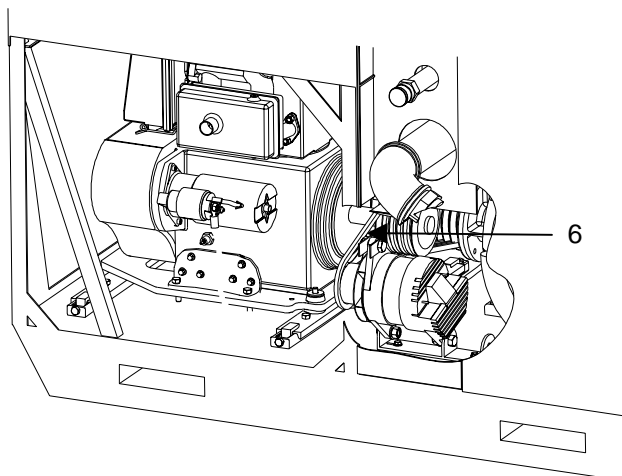
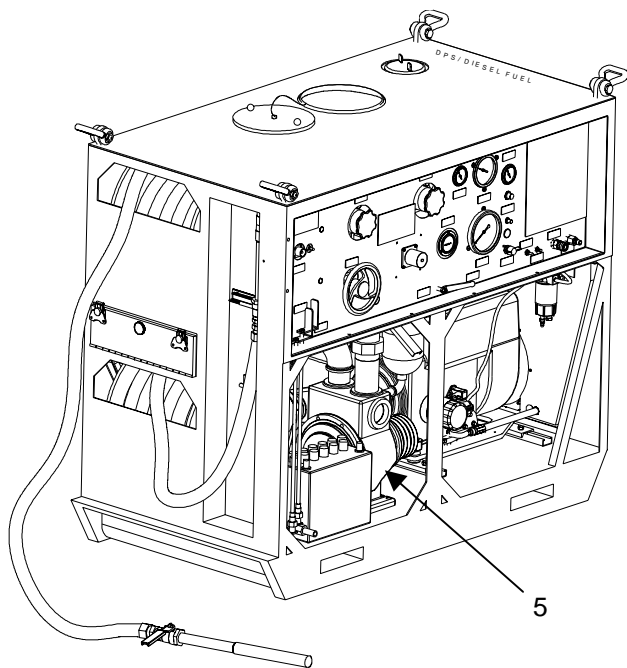

| Item No. | Interval | Man Hour | Item to be Checked/ Serviced | Procedure | Not Fully Mission Capable If: |
|----------|----------|----------|--------------------------------------|--|---|
| 5 | AFTER | | Pump Unit (Cont) Centrifugal Pump | <p>a. Inspect the pump housing for cracks, corrosion, and leaks.</p> <p>b. Visually check that the pump is tightly mounted to the skid base and that all piping connections do not leak.</p> | <p>Pump housing leaks continuously.</p> <p>Piping connections leak continuously, and pump is not mounted tightly.</p> |
| 6 | AFTER | | Drive Belts | Check pump and alternator drive belts for wear, breaks, or fraying. Check for proper tension: 5-7 lb at 3/8-inch deflection (WP 0023 00). | One or more belts broken or missing. Tension incorrect. |

OPERATOR'S PREVENTIVE MAINTENANCE CHECKS AND SERVICES (PMCS)

Table 1. After Operation PMCS for M12A1 DED Decontaminating Apparatus.

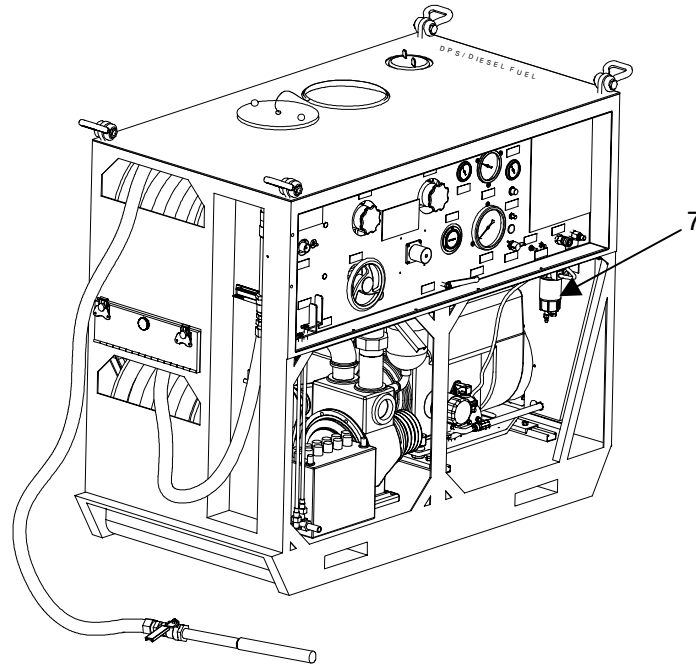

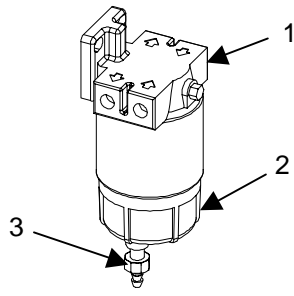

| Item No. | Interval | Man Hour | Item to be Checked/ Serviced | Procedure | Not Fully Mission Capable If: |
|----------|----------|----------|-------------------------------------|--|--|
| 7 | AFTER | | Pump Unit (Cont) Fuel Filter | a. Inspect pump unit fuel filter (1) for cracks or leaks. b. Inspect for accumulation of dirt or water in plastic bowl (2). If contaminants visible, drain fuel filter as follows: (1) Position container under drain plug (3). (2) Loosen drain plug (3). Allow fuel to drain into container until contaminants are gone. (3) Tighten drain plug (3) and check for leakage. | Fuel filter cracked or leaking. Unable to drain contaminants from filter. |

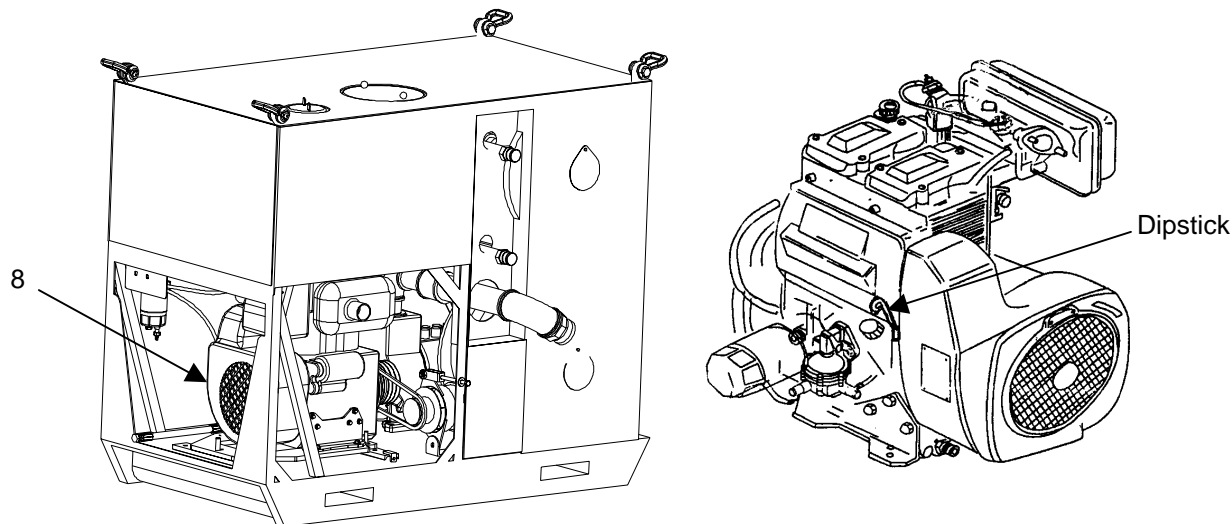

OPERATOR'S PREVENTIVE MAINTENANCE CHECKS AND SERVICES (PMCS)

Table 1. After Operation PMCS for M12A1 DED Decontaminating Apparatus.



| Item No. | Interval | Man Hour | Item to be Checked/ Serviced | Procedure | Not Fully Mission Capable If: |
|----------|----------|----------|-------------------------------------|---|-------------------------------|
| 8 | AFTER | | Pump Unit (Cont) Engine Assembly | Pull up the oil dipstick and check engine oil level (oil level should be between tic marks). Add oil if necessary (Page 0028 00-2, item 16 or 17). Recheck oil level until oil is between tic marks. Do not overfill. | |
| 9 | AFTER | | LOW OIL PRESSURE LIGHT | Turn IGNITION switch to RUN but do not start engine. LOW OIL PRESSURE LIGHT should illuminate. <div style="text-align: center;">  <div style="border: 1px solid black; padding: 5px; display: inline-block;"> LOW OIL PRESSURE LIGHT </div> </div> | Light does not illuminate. |

OPERATOR'S PREVENTIVE MAINTENANCE CHECKS AND SERVICES (PMCS)

Table 1. After Operation PMCS for M12A1 DED Decontaminating Apparatus.

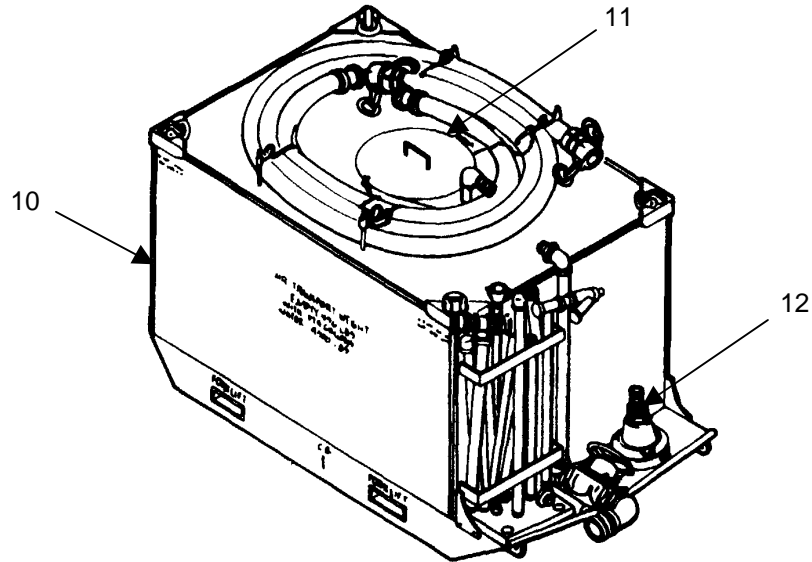

| Item No. | Interval | Man Hour | Item to be Checked/ Serviced | Procedure | Not Fully Mission Capable If: |
|----------|----------|-----------------|--|---|-------------------------------|
| 10 | AFTER | | Tank Unit | <p>a. Check that suction hose is stowed properly on top of the tank unit.</p> <p>b. Inspect the tank interior to see that it is clean and no slurry has accumulated or hardened on the tank walls.</p> <p>c. Check for slurry deposits on tank drain valve. Wash with hot, soapy water, then rinse with clear water. Remove rust and slurry deposits with a wire brush (Page 0028 00-1, item 5). Repaint as needed (Page 0028 00-3, item 20).</p> | Screen is completely blocked. |
| 11 | AFTER | Hopper Assembly | Check that dry slurry has not accumulated on inside screen. | | |
| 12 | AFTER | Foot Valve | Make sure that the valve is securely mounted to the skid base. | | |

OPERATOR'S PREVENTIVE MAINTENANCE CHECKS AND SERVICES (PMCS)

Table 1. After Operation PMCS for M12A1 DED Decontaminating Apparatus.

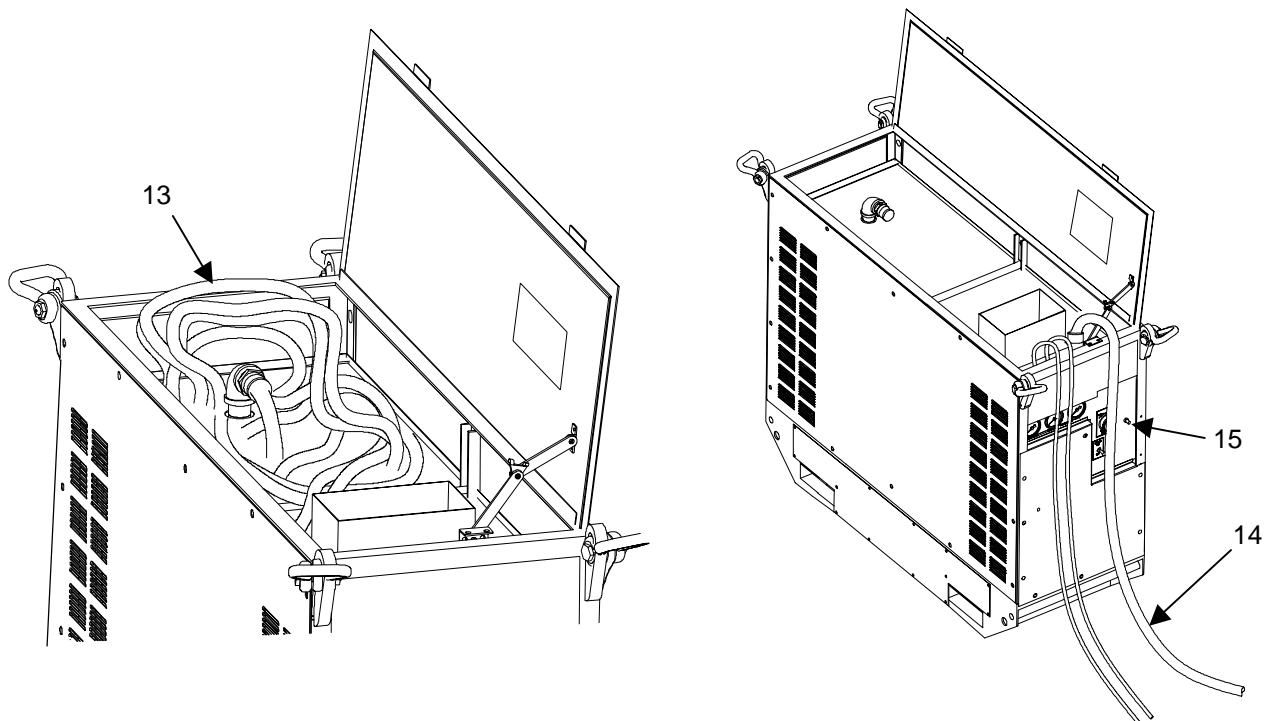

| Item No. | Interval | Man Hour | Item to be Checked/ Serviced | Procedure | Not Fully Mission Capable If: |
|----------|----------|----------|------------------------------|--|--|
| 13 | AFTER | | Water Heater | Inspect to see that all cables and hoses are properly stored in storage compartment. | Badly worn cable. Unworkable plug connector. |
| 14 | AFTER | | Power Cable | a. Check for cuts or breaks. Check fuel hose connectors for ease of operation. b. Check that connectors are clean and free of foreign matter. | |
| 15 | AFTER | | Control Box Assembly | Inspect to see that the glass in the fuel, water, and temperature gages is not broken. | |

OPERATOR'S PREVENTIVE MAINTENANCE CHECKS AND SERVICES (PMCS)

Table 1. After Operation PMCS for M12A1 DED Decontaminating Apparatus.

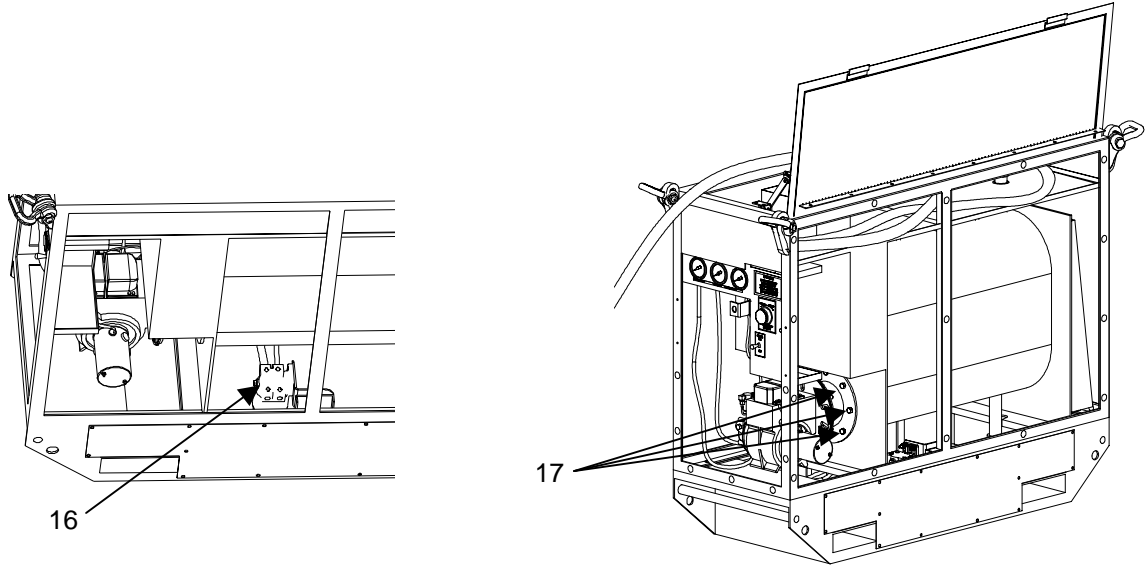

| Item No. | Interval | Man Hour | Item to be Checked/ Serviced | Procedure | Not Fully Mission Capable If: |
|----------|----------|----------|------------------------------|---|---|
| 16 | AFTER | | Fuel Filter | <p>a. Inspect pump unit fuel filter (1) for cracks or leaks.</p> <p>b. Inspect for accumulation of dirt or water in plastic bowl (2). If contaminants visible, drain fuel filter as follows:</p> <ol style="list-style-type: none"> (1) Position container under drain plug (3). (2) Loosen drain plug (3). Allow fuel to drain into container until contaminants are gone. (3) Tighten drain plug (3) and check for leakage | <p>Fuel filter cracked or leaking.</p> <p>Unable to drain contaminants from filter.</p> |
| 17 | AFTER | | Burner Assembly | <p>Check burner assembly for fuel leaks, damaged fuel lines, and electrical wiring. Check boiler-to-burner interface for loose bolts.</p> | |

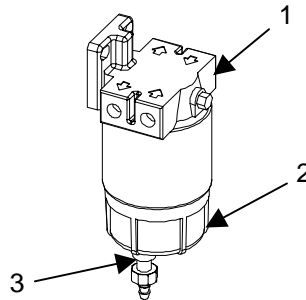

OPERATOR'S PREVENTIVE MAINTENANCE CHECKS AND SERVICES (PMCS) - Continued

Table 1. After Operation PMCS for M12A1 DED Decontaminating Apparatus - Continued.

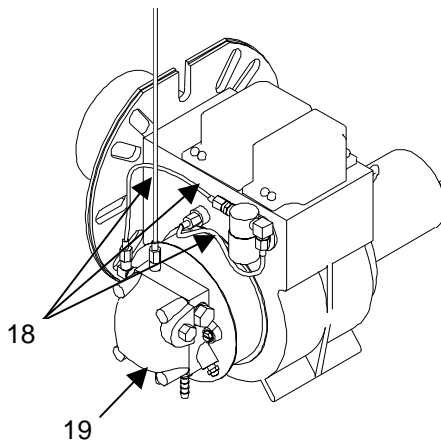

| Item No. | Interval | Man Hour | Item to be Checked/ Serviced | Procedure | Not Fully Mission Capable If: |
|----------|----------|----------|------------------------------|--|---|
| 18 | AFTER | | Fabricated Lines | Check to see that pressure lines are not leaking. | Fuel lines leak. |
| 19 | AFTER | | Fuel Pump | Check for leaks from pump, piping, and hose connections while operating. | Any leaks are present. (Because of extreme hazard of fuel vapors, the water heater must not be operated until the leak has been corrected.) |

END OF WORK PACKAGE

**OPERATOR
M12A1 DIESEL ENGINE DRIVEN DECONTAMINATION APPARATUS
NSN 4230-01-502-7224
QUARTERLY AND ANNUAL PREVENTIVE MAINTENANCE CHECKS AND SERVICES (PMCS)**

INITIAL SETUP:

Materials/Parts

- Brush, chassis and running gear (Page 0028 00-1, item 3)
- Brush, wire (Page 0028 00-1, item 5)
- Cleaning compound, solvent (Page 0028 00-2, item 7)
- Detergent (Page 0028 00-2, item 9)
- Enamel yellow (Page 0028 00-2, item 12)
- Lubricating oil (Page 0028 00-2, item 16 or 17)

- Lubricating oil, PL-S (Page 0028 00-3, item 19)
- Polyurethane coating (Page 0028 00-3, item 20)
- Rag, wiping (Page 0028 00-3, item 21)
- Tape, pressure sensitive (Page 0028 00-3, item 26)

References

WP 0020 00

OPERATOR'S PREVENTIVE MAINTENANCE CHECKS AND SERVICES (PMCS)

Table 1. Quarterly and Annual PMCS for M12A1 DED Decontaminating Apparatus.

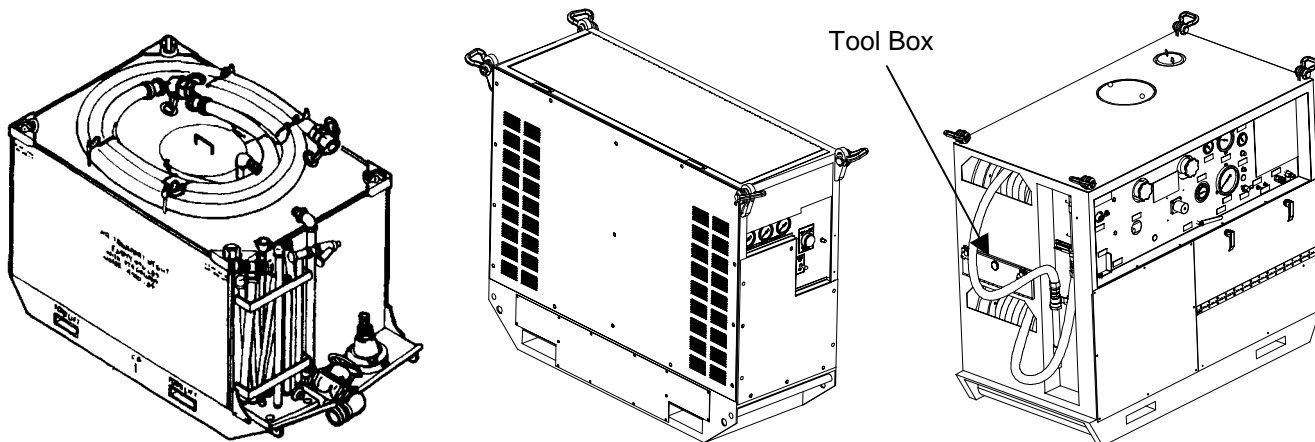

| Item No. | Interval | Man Hour | Item to be Checked/ Serviced | Procedure | Not Fully Mission Capable If: |
|----------|-----------|----------|------------------------------|--|--|
| 1 | QUARTERLY | | M12A1 DED Decon | a. Make sure all of the on-board tools and required spare parts are in the tool box between the pump unit upper and lower hose reels. b. Make sure one crank handle is in the tool box between the pump unit upper and lower hose reels. c. Check that the units are complete and undamaged. | One or more of the units are incomplete, damaged, or inoperable. |

OPERATOR'S PREVENTIVE MAINTENANCE CHECKS AND SERVICES (PMCS) - Continued

Table 1. Quarterly and Annual PMCS for M12A1 DED Decontaminating Apparatus - Continued.

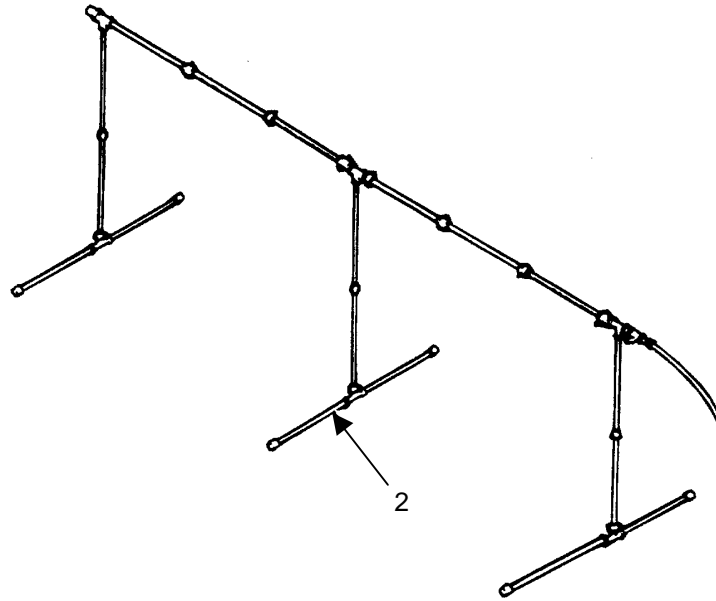

| Item No. | Interval | Man Hour | Item to be Checked/ Serviced | Procedure | Not Fully Mission Capable If: |
|----------|-----------|----------|------------------------------|---|-----------------------------------|
| 2 | QUARTERLY | | Personnel Shower Assembly | a. Inspect the exterior surfaces of the pipes and fittings for out of round and broken parts. b. Inspect exterior surfaces of pipes and fittings for rust, corrosion, looseness, damage, cracks, or deformation. Remove external scale or rust with a wire brush (Page 0028 00-1, item 5). Clean personnel shower assembly with clear water. Repaint (Page 0028 00-3, item 20) exterior surfaces if the paint is worn or chipped. When disassembling the personnel shower assembly, avoid damaging threads or burring the pipes or the fittings. | Parts are broken or out of round. |

OPERATOR'S PREVENTIVE MAINTENANCE CHECKS AND SERVICES (PMCS) - Continued

Table 1. Quarterly and Annual PMCS for M12A1 DED Decontaminating Apparatus - Continued.

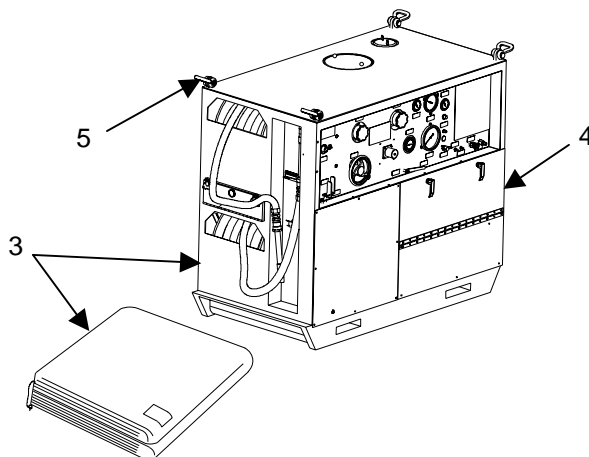

| Item No. | Interval | Man Hour | Item to be Checked/ Serviced | Procedure | Not Fully Mission Capable If: |
|----------|-----------|----------|-------------------------------|--|-------------------------------|
| 3 | QUARTERLY | | Pump Unit | a. Inspect pump unit for rust or corrosion. Remove any rust or corrosion with wire brush (Page 0028 00-1, item 5). Repaint pump unit with paint (Page 0028 00-3, item 20). b. Inspect pump unit surfaces for cracks, dents, damage, and deformation. (1) Clean the exterior of the pump unit with hot, soapy water then rinse with clear water. (2) Lubricate according to Lubrication Instructions (WP 0020 00). c. Inspect canvas cover to see that all buckles, snaps, and straps are in good condition and not corroded or damaged. If cover is unserviceable and needs to be replaced, notify Unit Maintenance. | |
| 4 | QUARTERLY | | Cover Panels | a. Wash panels with hot soapy water and rinse with clear water. Remove any rust with wire brush (Page 0028 00-1, item 5) and repaint (Page 0028 00-3, item 20). b. Lubricate panel hinges using PL-S (Page 0028 00-3, item 19). | |
| 5 | QUARTERLY | | Clevis and Eyebolt Assemblies | Check that the assemblies can be removed easily from the frame and are not damaged. Check for damaged threads. Make sure the clevis and eyebolt assemblies are securely in place and are free of burrs, and cracks. | |

OPERATOR'S PREVENTIVE MAINTENANCE CHECKS AND SERVICES (PMCS) - Continued

Table 1. Quarterly and Annual PMCS for M12A1 DED Decontaminating Apparatus - Continued.

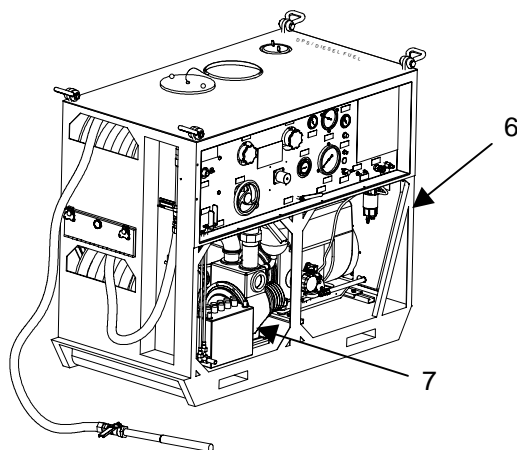

| Item No. | Interval | Man Hour | Item to be Checked/ Serviced | Procedure | Not Fully Mission Capable If: |
|----------|-----------|----------|------------------------------|---|---|
| 6 | QUARTERLY | | Pump Unit Assembly | <p>a. Inspect for damage, rust, or corrosion.</p> <p style="text-align: center;">WARNING</p> <p style="text-align: center;">Fire and explosion danger exist when solvent cleaning compound is used. Make sure that equipment is dry before operations begin.</p> <p>b. Clean unpainted metal parts and interior of pump unit assembly with a cloth dampened with solvent cleaning compound (Page 0028 00-2, item 7). Dry interior of pump unit assembly thoroughly. Use hot, soapy water and a brush to remove hardened slurry or dirt from the exterior surfaces.</p> | |
| 7 | QUARTERLY | | Battery | <p>a. See that the battery is fully charged. See that the positive and ground cables are attached properly to the battery terminals and to the engine. See that the battery is fastened tightly to the pump unit skid.</p> <p>b. Check electrolyte level. If electrolyte is not filled to ledge in filler opening, notify Unit Maintenance.</p> <p>c. Check that vent holes in vent caps are clear.</p> <p>d. Inspect frame area terminals, clamps, cables, and hold-downs for corrosion.</p> | <p>Battery is unserviceable.</p> <p>Electrolyte level is low.</p> |

OPERATOR’S PREVENTIVE MAINTENANCE CHECKS AND SERVICES (PMCS) – Continued

Table 1. Quarterly and Annual PMCS for M12A1 DED Decontaminating Apparatus - Continued.

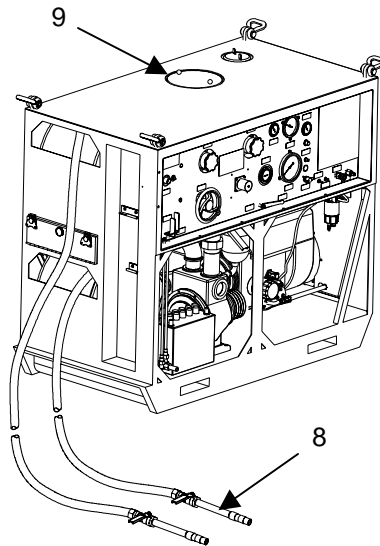

| Item No. | Interval | Man Hour | Item to be Checked/ Serviced | Procedure | Not Fully Mission Capable If: |
|----------|-----------|----------|--|---|-------------------------------|
| 8 | QUARTERLY | | Gun Assembly and Slurry Nozzle Assembly | <p>a. Inspect the gun assembly and slurry nozzle assembly for dirt and hardened slurry. Inspect the threaded fittings for nicks, burrs, or other damage. Inspect the gun handle for cracks, chips, twists, bends, or other damage that would interfere with efficient operation. Inspect the extension pipe and adapter for cracks, bends, holes, being out of round, or other damage that would affect operation of the gun assembly.</p> <p>b. Clean the hardened slurry or dirt from the gun and slurry nozzle assembly. Be especially careful to clean the hard-to-reach areas around the gun handle and the adapter threads.</p> <p>(1) Thoroughly clean all nozzles that have been used to spray liquids other than water.</p> <p>(2) Use soapy water and a small brush (Page 0028 00-1, item 3) to loosen the dirt. Rinse with clean water, and dry all parts thoroughly.</p> <p>(3) Inspect the gasket for cuts, wear, and deformation.</p> | Nozzle is clogged. |
| 9 | QUARTERLY | | Prime-Detergent Tank Assembly and Tank Lid | <p>a. See that the tank is fastened to the pump unit. See that the tank lid is in place.</p> <p>b. Inspect tank lid for cracks and for loose, missing and corroded parts.</p> | |

OPERATOR'S PREVENTIVE MAINTENANCE CHECKS AND SERVICES (PMCS) – Continued

Table 1. Quarterly and Annual PMCS for M12A1 DED Decontaminating Apparatus - Continued.

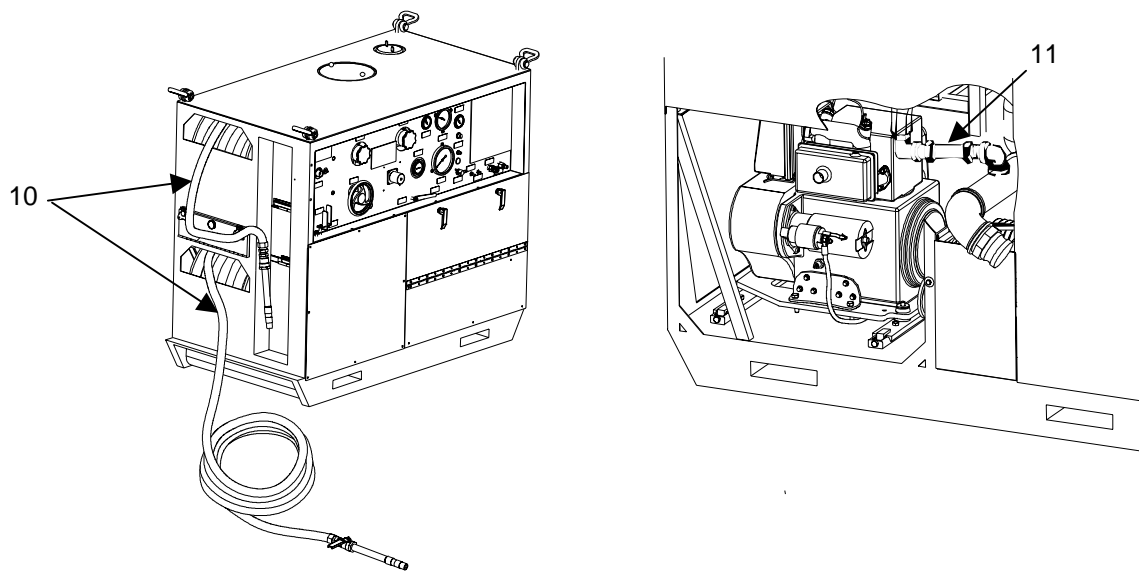

| Item No. | Interval | Man Hour | Item to be Checked/ Serviced | Procedure | Not Fully Mission Capable If: |
|----------|-----------|----------|------------------------------|---|---|
| 10 | QUARTERLY | | Discharge Hose Assemblies | <p>a. Inspect discharge hoses for leaks, breaks, or other damage.</p> <p style="text-align: center;">WARNING</p> <p style="text-align: center;">Fire and explosion danger exist when solvent cleaning compound is used. Make sure that equipment is dry before operations begin.</p> <p>b. Flush hoses with hot water. Wash exterior of discharge hoses with hot, soapy water. Dry all parts thoroughly. Clean metal parts with a cloth (Page 0028 00-3, item 21) dampened with solvent cleaning compound (Page 0028 00-2, item 7), if required.</p> | Both discharge hoses leak continuously. |
| 11 | QUARTERLY | | Eductor Hose Assembly | <p>a. Inspect the eductor hose for leaks or breaks.</p> <p>b. Make sure hose clamps are tight.</p> | Eductor hose leaks. |

OPERATOR'S PREVENTIVE MAINTENANCE CHECKS AND SERVICES (PMCS) – Continued

Table 1. Quarterly and Annual PMCS for M12A1 DED Decontaminating Apparatus - Continued.

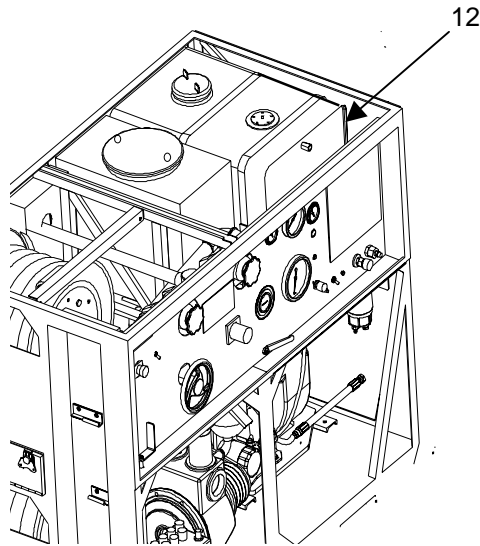

| Item No. | Interval | Man Hour | Item to be Checked/ Serviced | Procedure | Not Fully Mission Capable If: |
|----------|-----------|----------|------------------------------|---|-------------------------------|
| 12 | QUARTERLY | | Fuel Tank | <p style="text-align: center;">WARNING</p> <p>Fire and explosion danger exist when solvent cleaning compound is used. Make sure that equipment is dry before operations begin.</p> <p>Fuel must be removed from fuel tank before using wire brush.</p> <p>a. Clean outside of tank with solvent cleaning compound (Page 0028 00-2, item 7). Dry thoroughly.</p> <p>b. Remove any rust and corrosion from outside of tank using a wire brush (Page 0028 00-1, item 5).</p> <p>c. Repaint outside of tank or fuel cap (Page 0028 00-3, item 20) as necessary. Stencil fuel cap lettering with yellow paint (Page 0028 00-2, item 12) as necessary.</p> | |

OPERATOR'S PREVENTIVE MAINTENANCE CHECKS AND SERVICES (PMCS) – Continued

Table 1. Quarterly and Annual PMCS for M12A1 DED Decontaminating Apparatus - Continued.

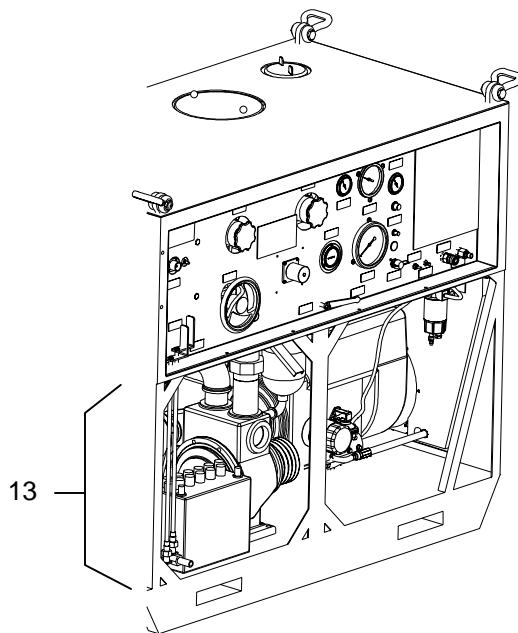

| Item No. | Interval | Man Hour | Item to be Checked/ Serviced | Procedure | Not Fully Mission Capable If: |
|----------|-----------|----------|------------------------------|--|---|
| 13 | QUARTERLY | | Pump Unit Subassembly | <p>a. Check that washers, nuts, and bolts are securely in place.</p> <p>b. Check that centrifugal pump support is not broken, cracked, or dented.</p> <p style="text-align: center;">WARNING</p> <p style="text-align: center;">Fire and explosion danger exist when solvent cleaning compound is used. Make sure that equipment is dry before operations begin.</p> <p>c. Clean pump unit subassembly with solvent cleaning compound (Page 0028 00-2, item 7). Dry thoroughly. Remove any rust and corrosion with a wire brush (Page 0028 00-1, item 5). Repaint (Page 0028 00-3, item 20) as necessary.</p> | <p>Washers, nuts, and bolts are loose or missing.</p> <p>Centrifugal pump support is broken or missing.</p> |

OPERATOR'S PREVENTIVE MAINTENANCE CHECKS AND SERVICES (PMCS) – Continued

Table 1. Quarterly and Annual PMCS for M12A1 DED Decontaminating Apparatus - Continued.

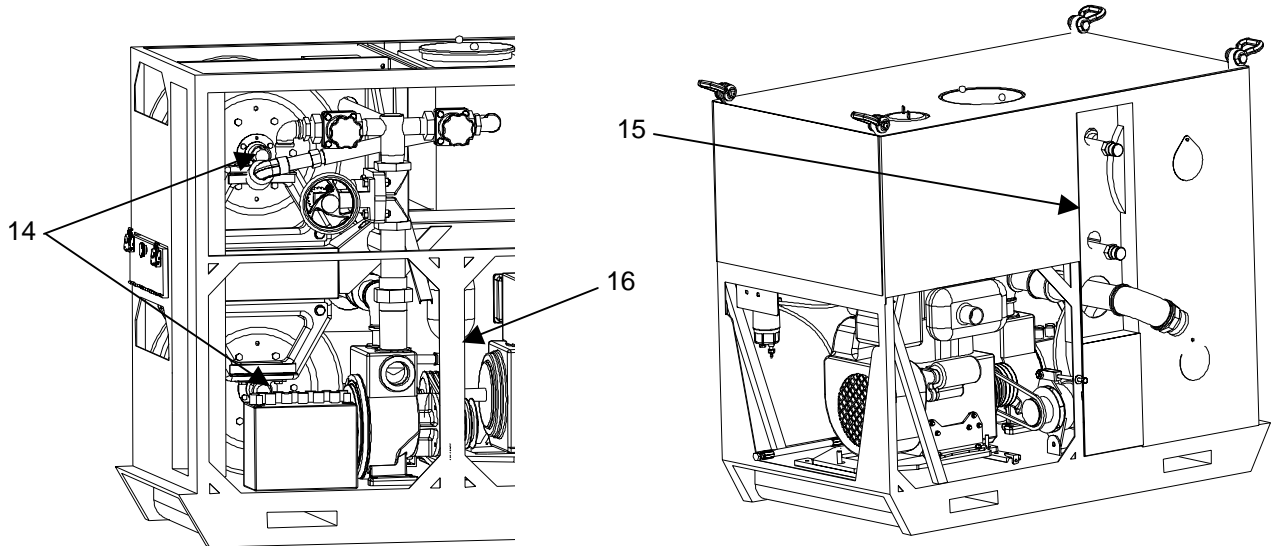

| Item No. | Interval | Man Hour | Item to be Checked/ Serviced | Procedure | Not Fully Mission Capable If: |
|----------|-----------|----------|------------------------------|---|-------------------------------|
| 14 | QUARTERLY | | Hose Reel | a. Inspect that the two lubrication fittings on the swivel pipes are clean and not broken. b. Remove any rust with wire brush (Page 0028 00-1, item 5) and repaint (Page 0028 00-3, item 20). | |
| 15 | QUARTERLY | | Connector Panel | a. Inspect that the chains connected to the dust caps are in good condition and are securely fastened. b. Clean connector panel with hot soapy water and rinse with clear water. | |
| 16 | QUARTERLY | | Frame Assembly | a. Inspect for missing hardware or parts. b. Inspect for broken welds or dents. c. Wash with hot soapy water. Rinse with clear water. Remove any rust and corrosion with a wire brush (Page 0028 00-1, item 5). Repaint (Page 0028 00-3, item 20) as necessary. | |

OPERATOR'S PREVENTIVE MAINTENANCE CHECKS AND SERVICES (PMCS) – Continued

Table 1. Quarterly and Annual PMCS for M12A1 DED Decontaminating Apparatus - Continued.

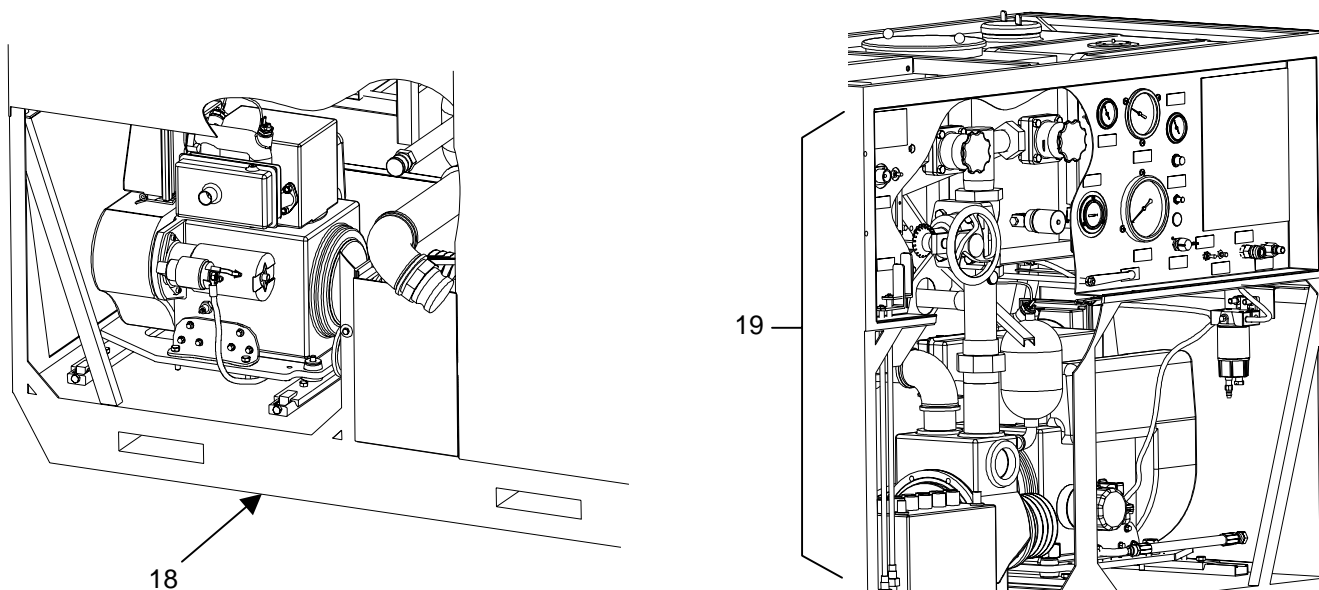

| Item No. | Interval | Man Hour | Item to be Checked/ Serviced | Procedure | Not Fully Mission Capable If: |
|----------|-----------|----------|------------------------------|---|-------------------------------|
| 18 | QUARTERLY | | Skid Base Subassembly | Inspect for rust, corrosion, broken welds, dents, or loose hardware. | |
| 19 | QUARTERLY | | Plumbing Assembly | <p style="text-align: center;">WARNING</p> <p>Fire and explosion danger exist when solvent cleaning compound is used. Make sure that equipment is dry before operations begin.</p> <p>Clean with solvent cleaning compound (Page 0028 00-2, item 7); dry thoroughly. Remove rust and corrosion with a wire brush (Page 0028 00-1, item 5). Repaint as necessary (Page 0028 00-3, item 20).</p> | |

OPERATOR'S PREVENTIVE MAINTENANCE CHECKS AND SERVICES (PMCS) – Continued

Table 1. Quarterly and Annual PMCS for M12A1 DED Decontaminating Apparatus - Continued.

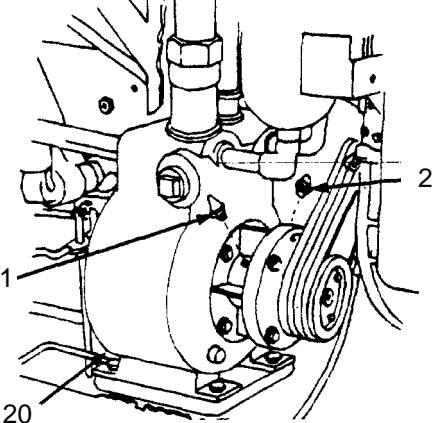
| Item No. | Interval | Man Hour | Item to be Checked/ Serviced | Procedure | Not Fully Mission Capable If: |
|----------|-----------|----------|------------------------------|--|-------------------------------|
| 20 | QUARTERLY | | Centrifugal Pump | <p>a. Inspect that lube fitting (1) and breather (2) are not broken or missing.</p>  <p>WARNING</p> <p>Fire and explosion danger exist when solvent cleaning compound is used. Make sure that equipment is dry before operations begin.</p> <p>b. Lubricate in accordance with Lubrication Instructions (WP 0020 00).</p> <p>c. Wash outside of pump with solvent cleaning compound (Page 0028 00-2, item 7). Dry thoroughly. Remove rust and corrosion with a wire brush (Page 0028 00-1, item 5). Repaint (Page 0028 00-3, item 20) as necessary.</p> | |

OPERATOR'S PREVENTIVE MAINTENANCE CHECKS AND SERVICES (PMCS) – Continued

Table 1. Quarterly and Annual PMCS for M12A1 DED Decontaminating Apparatus - Continued.

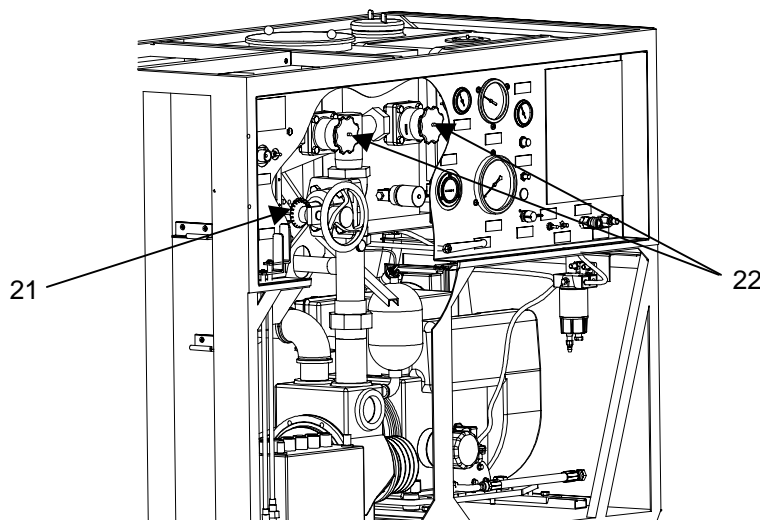

| Item No. | Interval | Man Hour | Item to be Checked/ Serviced | Procedure | Not Fully Mission Capable If: |
|----------|-----------|----------|--|---|---|
| 21 | QUARTERLY | | VALVE NO. 1 MANIFOLD | a. Check that mounting hardware is tight. Inspect valve and associated piping for leaks or rust. Turn valve handle and check that valve turns smoothly and easily. b. Lubricate bevel gear according to Lubrication Instructions (WP 0020 00). c. Remove any rust or corrosion with wire brush (Page 0028 00-1, item 5). Repaint (Page 0028 00-3, item 20) as required. Wash with hot soapy water and rinse with clean water. | Valve does not open or close completely, or valve leaks continuously. |
| 22 | QUARTERLY | | VALVE NO. 2 LOWER REEL and VALVE NO. 3 UPPER REEL | a. Check that the valves turn smoothly. b. Lubricate valve stems according to Lubrication Instructions (WP 0020 00). <p style="text-align: center;">WARNING</p> Fire and explosion danger exist when solvent cleaning compound is used. Make sure that equipment is dry before operations begin. c. Clean regulating valves with solvent cleaning compound (Page 0028 00-2, item 7) and dry. | |

OPERATOR'S PREVENTIVE MAINTENANCE CHECKS AND SERVICES (PMCS) – Continued

Table 1. Quarterly and Annual PMCS for M12A1 DED Decontaminating Apparatus - Continued.

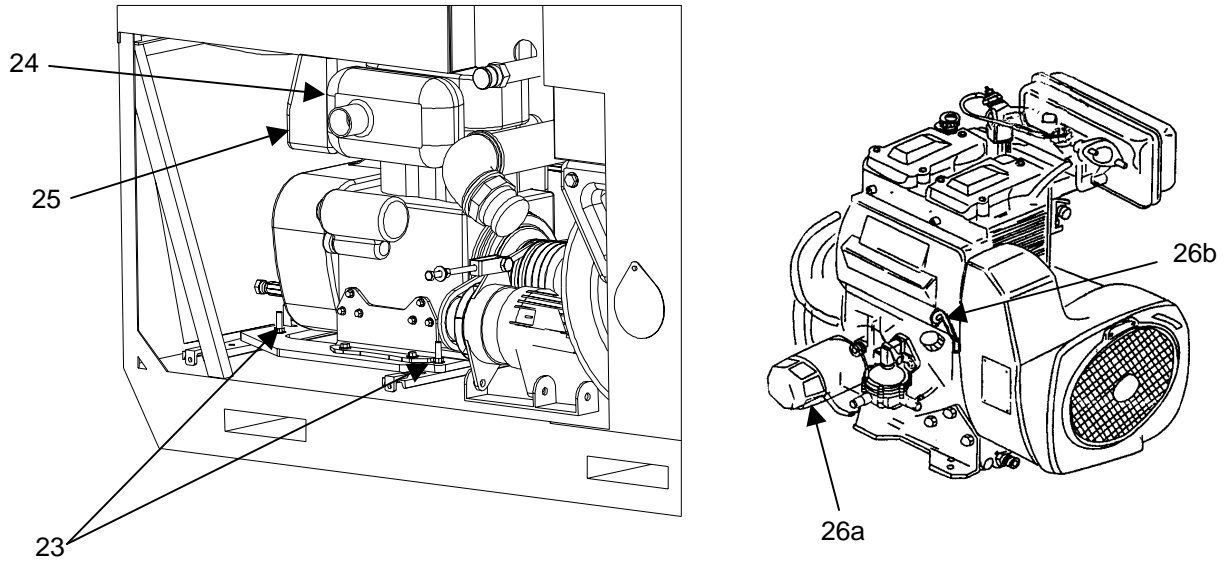

| Item No. | Interval | Man Hour | Item to be Checked/ Serviced | Procedure | Not Fully Mission Capable If: |
|----------|-----------|----------|----------------------------------|--|--|
| 23 | QUARTERLY | | Engine Assembly | Make sure that engine vibration mounts, nuts, and bolts are present and in good condition. | Engine mounts are missing. Bolts loose or missing. |
| 24 | QUARTERLY | | Muffler | Check muffler for loose or missing mounting nuts. If loose, tighten. | Mounting is damaged or mounting nuts are missing. |
| 25 | QUARTERLY | | Air Filter Assembly | Check that filter element is present and clean (WP 0024 00). Check that latches on air filter assembly are properly engaged. | Filter element is missing or clogged. |
| 26 | QUARTERLY | | Engine Oil and Engine Oil Filter | a. Check oil filter for leaks or damage. b. Pull up the oil dipstick and check engine oil level (oil level should be between tic marks). Add oil if necessary (Page 0028 00-2, item 16 or 17). Recheck oil level until oil is between tic marks. Do not overfill. | Class III leak. |

OPERATOR'S PREVENTIVE MAINTENANCE CHECKS AND SERVICES (PMCS) – Continued

Table 1. Quarterly and Annual PMCS for M12A1 DED Decontaminating Apparatus - Continued.

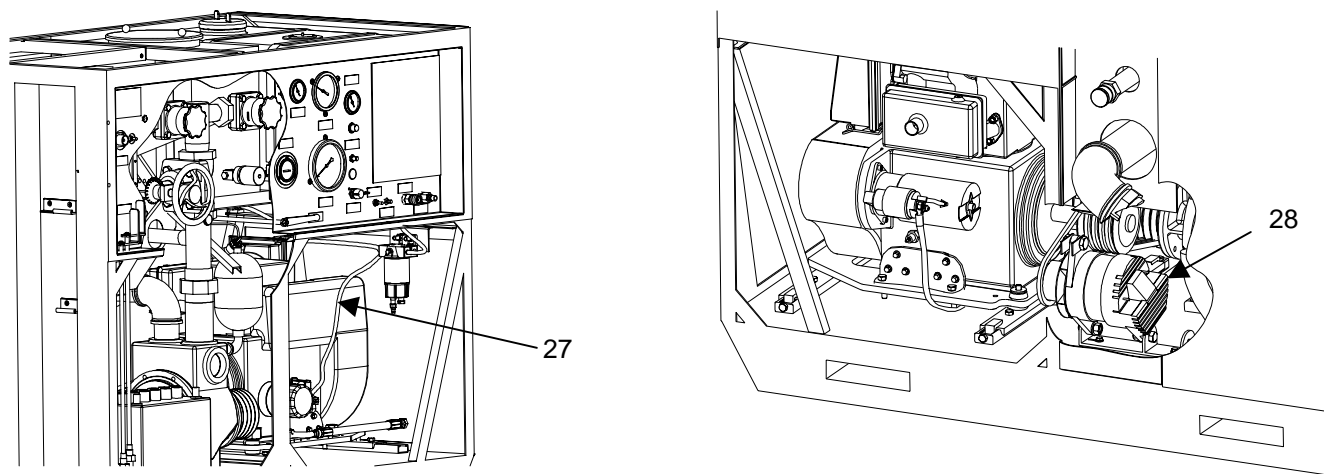

| Item No. | Interval | Man Hour | Item to be Checked/ Serviced | Procedure | Not Fully Mission Capable If: |
|----------|-----------|----------|------------------------------|---|-------------------------------|
| 27 | QUARTERLY | | Fuel Hose | <p style="text-align: center;">NOTE</p> <p>Fuel hose is black rubber hose, size 1/4". Fuel delivery hose is from fuel tank to fuel filter/water separator then to engine pump.</p> <p>Check fuel hoses for cuts, tears, leaks, damage or loose fittings. Tighten fittings as required.</p> | Any fuel leak. |
| 28 | QUARTERLY | | Alternator Assembly | <p>a. See that no parts are missing and that hardware fastening the assembly to the base is not loose or missing.</p> <p>b. Check that pulley is not bent or cracked.</p> <p style="text-align: center;">WARNING</p> <p>Fire and explosion danger exist when solvent cleaning compound is used. Make sure that equipment is dry before operations begin.</p> <p>c. Clean exterior of alternator with cloth dampened with solvent cleaning compound (Page 0028 00-2, item 7). Dry thoroughly. Remove any rust and corrosion with a wire brush (Page 0028 00-1, item 5).</p> | Pulley is bent or cracked. |

OPERATOR'S PREVENTIVE MAINTENANCE CHECKS AND SERVICES (PMCS) – Continued

Table 1. Quarterly and Annual PMCS for M12A1 DED Decontaminating Apparatus - Continued.

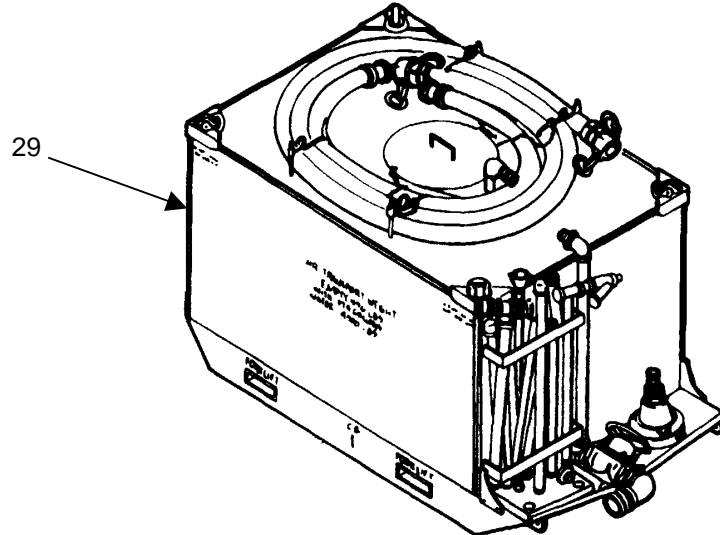

| Item No. | Interval | Man Hour | Item to be Checked/ Serviced | Procedure | Not Fully Mission Capable If: |
|----------|-----------|----------|------------------------------|---|-------------------------------|
| 29 | QUARTERLY | | Tank Unit | a. Check that tank is fastened to skid base assembly. b. Check that suction hose is stowed properly on top of the tank unit. c. Inspect for broken welds, leaks, obstructions, loose pipe fittings, and missing parts. d. Check that the markings and identification plates for the drain, agitator, and blender connectors are legible and firmly fastened. e. Inspect the tank interior to see that it is clean and no slurry has accumulated or hardened on the tank walls. f. Clean tank with hot, soapy water. Remove any slurry which may have accumulated using brush (Page 0028 00-1, item 3). Rinse with clear water. Remove rust and corrosion with wire brush (Page 0028 00-1, item 5). Repaint as necessary (Page 0028 00-3, item 20). | Tank leaks continuously. |

OPERATOR'S PREVENTIVE MAINTENANCE CHECKS AND SERVICES (PMCS) – Continued

Table 1. Quarterly and Annual PMCS for M12A1 DED Decontaminating Apparatus - Continued.

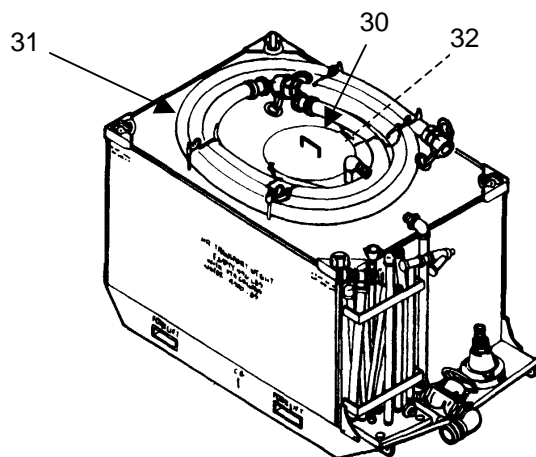

| Item No. | Interval | Man Hour | Item to be Checked/ Serviced | Procedure | Not Fully Mission Capable If: |
|----------|-----------|----------|------------------------------|--|---|
| 30 | QUARTERLY | | Hopper Assembly | a. Inspect the hopper assembly for broken welds and evidence of leaks. b. Check that quick disconnect on blender pipe is not out of round or loose. c. Check that scale, dry slurry, or other obstructions have not accumulated on inside screen, inside hopper, or in blender pipe. Clean any accumulated debris. d. Check that chains fasten the bolts to the bracket clamp. e. Check that the blender hose is coiled inside the hopper when not in use. | Quick disconnect is out of round or loose. Screen is completely blocked. |
| 31 | QUARTERLY | | Suction Hose Assembly | a. Inspect the suction hose assembly for leaks or breaks. b. Check that quick release couplings have gaskets installed. | Hose leaks continuously. Gaskets are missing. |
| 32 | QUARTERLY | | Blender Hose | a. Inspect the blender hose assembly for leaks or breaks. b. Check that quick release couplings have gaskets installed. | Hose leaks continuously. Gaskets are missing. |

OPERATOR'S PREVENTIVE MAINTENANCE CHECKS AND SERVICES (PMCS) – Continued

Table 1. Quarterly and Annual PMCS for M12A1 DED Decontaminating Apparatus - Continued.

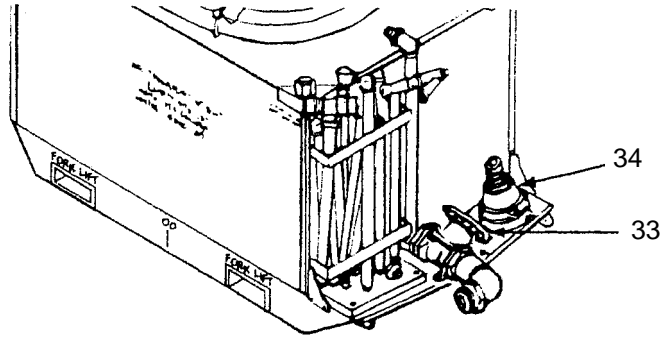

| Item No. | Interval | Man Hour | Item to be Checked/ Serviced | Procedure | Not Fully Mission Capable If: |
|----------|-----------|----------|------------------------------|---|---|
| 33 | QUARTERLY | | Tank Drain Valve | <p style="text-align: center;">WARNING</p> <p>When operating tank drain valve, be careful not to catch fingers in slot.</p> <ol style="list-style-type: none"> a. Check that the tank drain valve turns smoothly and that stem has been lubricated. b. Lubricate according to Lubrication Instructions (WP 0020 00). c. Inspect the tank drain valve for evidence of leaks, corrosion, or breaks. d. Check that all mounting hardware is tight and secure. e. Wash with hot, soapy water, then rinse with clear water. Remove rust and slurry deposits with a wire brush (Page 0028 00-1, item 5). Repaint as needed (Page 0028 00-3, item 20). | Drain valve does not turn or open and close completely. |
| 34 | QUARTERLY | | Foot Valve | <ol style="list-style-type: none"> a. Check the foot valve for missing parts. b. Check for breaks or cracks. c. Make sure that the valve is securely mounted to the skid base. | Parts are missing. |

OPERATOR’S PREVENTIVE MAINTENANCE CHECKS AND SERVICES (PMCS) – Continued

Table 1. Quarterly and Annual PMCS for M12A1 DED Decontaminating Apparatus - Continued.

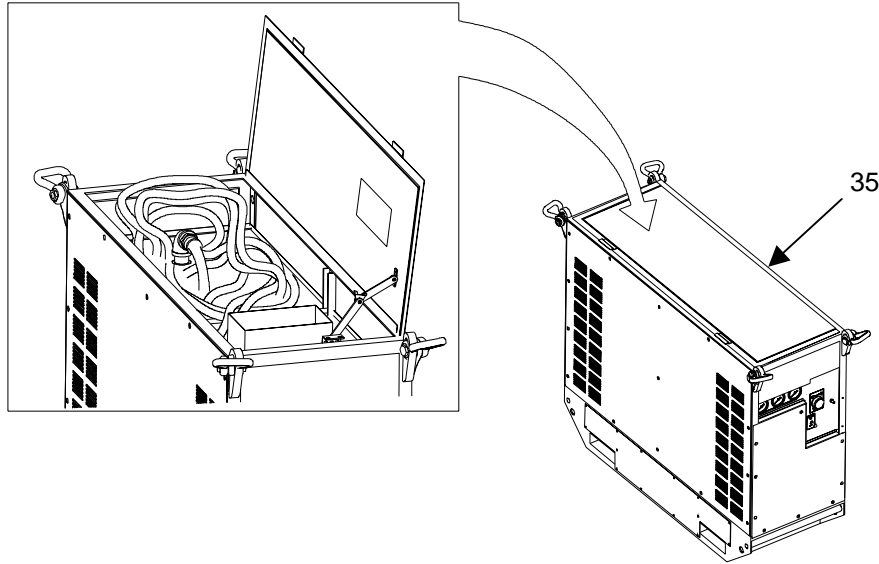

| Item No. | Interval | Man Hour | Item to be Checked/ Serviced | Procedure | Not Fully Mission Capable If: |
|----------|-----------|----------|------------------------------|---|--|
| 35 | QUARTERLY | | Water Heater | <p>a. Inspect to see that all cables and hoses are properly stored in storage compartment.</p> <p>b. Inspect for loose or missing nuts or bolts. Tighten hardware when necessary.</p> <p>c. Check that all decals, stencils, and identification plates are legible.</p> <p>d. Check that electrical wires are properly secured above boiler and not touching boiler.</p> <p style="text-align: center;">WARNING</p> <p style="text-align: center;">Fire and explosion danger exist when solvent cleaning compound is used. Make sure that equipment is dry before operations begin.</p> <p>e. Clean with solvent cleaning compound (Page 0028 00-2, item 7) and dry thoroughly. Remove rust and foreign material with wire brush (Page 0028 00-1, item 5). Repaint if necessary (Page 0028 00-3, item 20).</p> | <p>Identification plates are missing and TM is missing.</p> <p>Electrical wire clamp is missing.</p> |

OPERATOR’S PREVENTIVE MAINTENANCE CHECKS AND SERVICES (PMCS) – Continued

Table 1. Quarterly and Annual PMCS for M12A1 DED Decontaminating Apparatus - Continued.

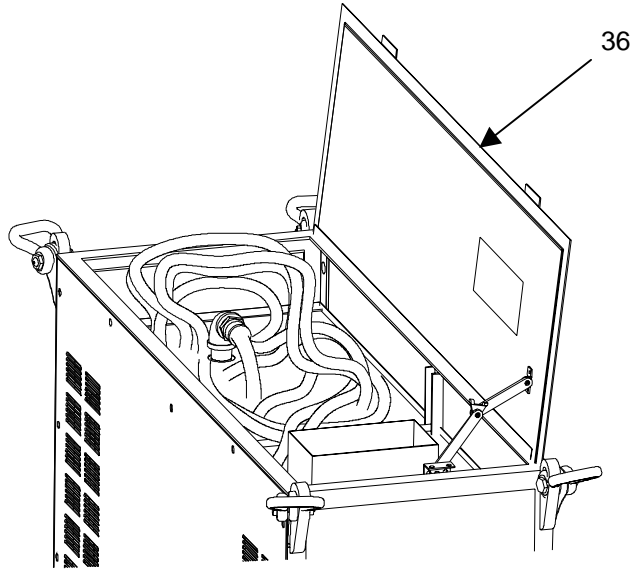

| Item No. | Interval | Man Hour | Item to be Checked/ Serviced | Procedure | Not Fully Mission Capable If: |
|----------|-----------|----------|------------------------------|--|-------------------------------|
| 36 | QUARTERLY | | Cabinet Top Cover | <p>a. Inspect the cover for loose, missing, bent, rusted, dirty, corroded, or worn out parts.</p> <p>b. Check that the cover is not cracked, that the painted surfaces are in good condition, and the hinges operate smoothly. Lubricate in accordance with Lubrication Instructions (WP 0020 00).</p> <p style="text-align: center;">WARNING</p> <p style="text-align: center;">Fire and explosion danger exist when solvent cleaning compound is used. Make sure that equipment is dry before operations begin.</p> <p>c. Clean lid with solvent cleaning compound (Page 0028 00-2, item 7) and dry thoroughly. Remove rust and corrosion with a wire brush (Page 0028 00-1, item 5). Repaint (Page 0028 00-3, item 20) as necessary.</p> | |

OPERATOR'S PREVENTIVE MAINTENANCE CHECKS AND SERVICES (PMCS) – Continued

Table 1. Quarterly and Annual PMCS for M12A1 DED Decontaminating Apparatus - Continued.

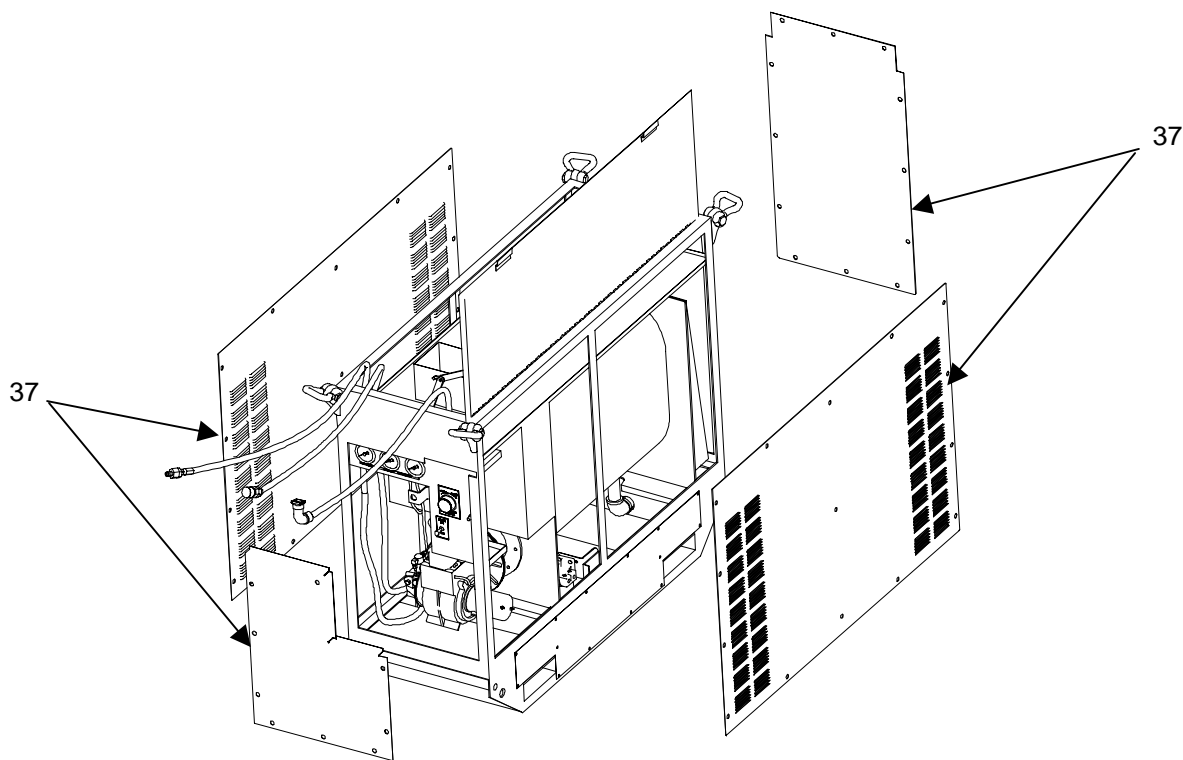

| Item No. | Interval | Man Hour | Item to be Checked/ Serviced | Procedure | Not Fully Mission Capable If: |
|----------|-----------|----------|------------------------------|---|-------------------------------|
| 37 | QUARTERLY | | Water Heater Cover Panels | a. Inspect panels for loose or missing parts. b. Inspect for dented or bent panels. c. Inspect condition of turnlock fastener stud assemblies. d. Wash panels with hot, soapy water. Rinse with clear water. Remove rust or corrosion with a wire brush (Page 0028 00-1, item 5). Repaint as necessary (Page 0028 00-3, item 20). e. Replace excessively blackened or loose heat reflective tape (Page 0028 00-3, item 26) in the same location as original tape. | |

OPERATOR'S PREVENTIVE MAINTENANCE CHECKS AND SERVICES (PMCS) – Continued

Table 1. Quarterly and Annual PMCS for M12A1 DED Decontaminating Apparatus - Continued.

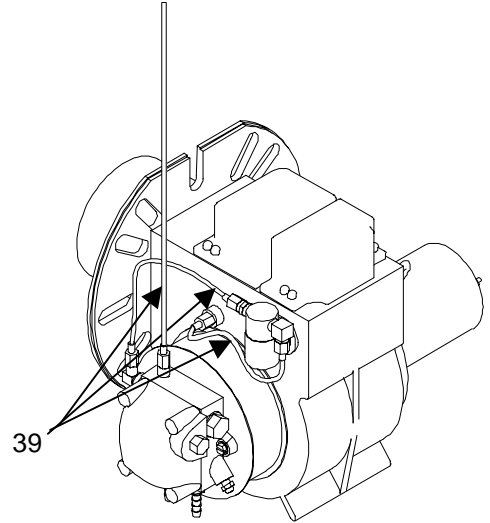
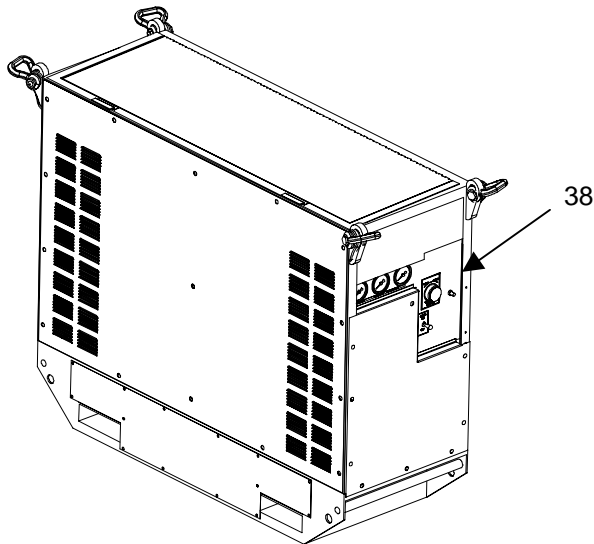

| Item No. | Interval | Man Hour | Item to be Checked/ Serviced | Procedure | Not Fully Mission Capable If: |
|----------|-----------|----------|------------------------------|---|-------------------------------|
| 38 | QUARTERLY | | Control Box Assembly | a. Inspect control box for broken, missing, or loose parts. Tighten as necessary. b. Inspect to see that the glass in the fuel, water, and temperature gages is not broken. c. Wash front panel and gage faces with hot, soapy water. Rinse with clear water. Remove rust and corrosion with a wire brush (Page 0028 00-1, item 5). Repaint as necessary (Page 0028 00-3, item 20). | |
| 39 | QUARTERLY | | Fabricated Lines | Check all the fabricated lines for signs of kinks and sharp bends. | Lines are kinked. |

OPERATOR'S PREVENTIVE MAINTENANCE CHECKS AND SERVICES (PMCS) – Continued

Table 1. Quarterly and Annual PMCS for M12A1 DED Decontaminating Apparatus - Continued.

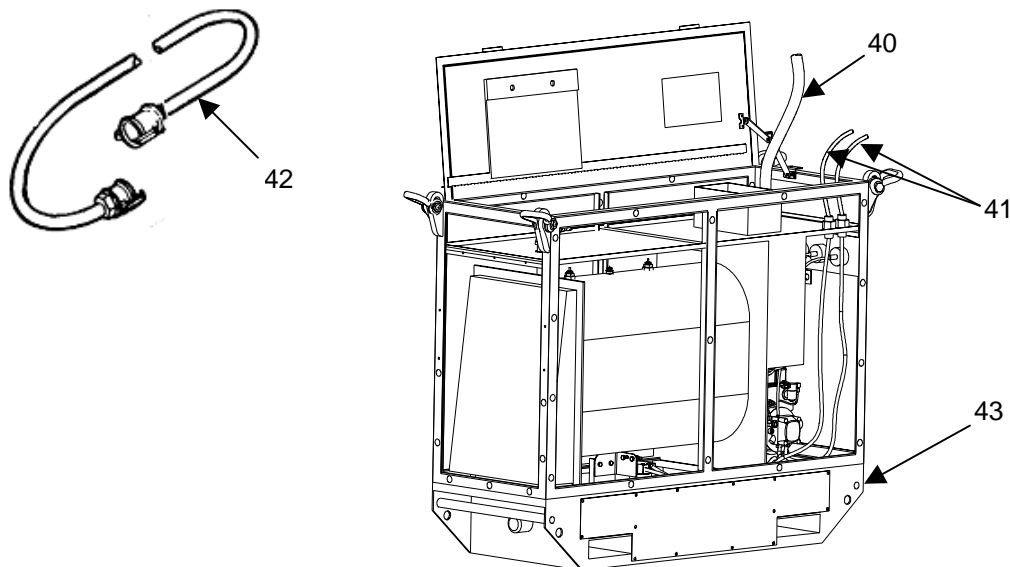

| Item No. | Interval | Man Hour | Item to be Checked/ Serviced | Procedure | Not Fully Mission Capable If: |
|----------|-----------|----------|------------------------------|---|--|
| 40 | QUARTERLY | | Power Cable | Check for cracks, deterioration, bare or frayed wire, and kinks. | Badly worn cable. Unworkable plug connector. |
| 41 | QUARTERLY | | Fuel Hoses | Check for cuts or breaks. Check fuel hose connectors for ease of operation. | Unserviceable hose or connectors. |
| 42 | QUARTERLY | | Water Hose | a. Inspect for cracks and broken or missing parts or gaskets. b. Check that quick disconnect couplings are properly installed and gaskets are present. | Gaskets are missing. |
| 43 | QUARTERLY | | Skid Assembly | a. Inspect all skid assembly components for rust, corrosion, broken welds, dents, or loose hardware. b. Inspect to see if any wires are loose or disconnected. | Wires are disconnected. |

OPERATOR’S PREVENTIVE MAINTENANCE CHECKS AND SERVICES (PMCS) – Continued

Table 1. Quarterly and Annual PMCS for M12A1 DED Decontaminating Apparatus - Continued.

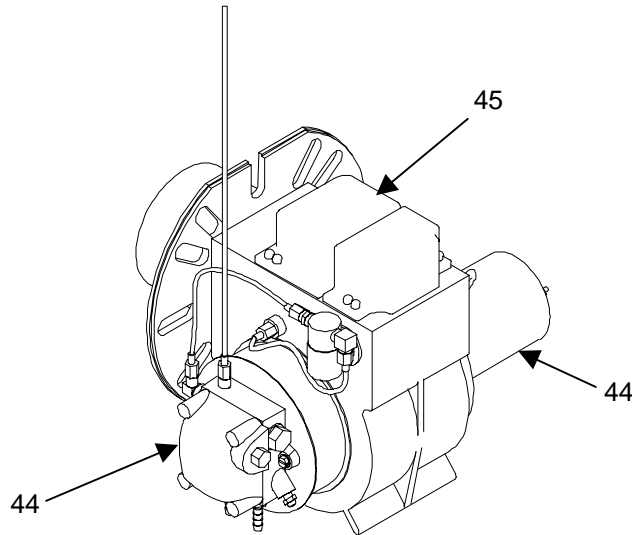

| Item No. | Interval | Man Hour | Item to be Checked/ Serviced | Procedure | Not Fully Mission Capable If: |
|----------|-----------|----------|------------------------------|---|--|
| 44 | QUARTERLY | | Fuel Pump and Blower Motor | <p>a. See that all mounting hardware is present and secure.</p> <p style="text-align: center;">WARNING</p> <p>Fire and explosion danger exist when solvent cleaning compound is used. Make sure that equipment is dry before operations begin.</p> <p>b. Wipe with a clean cloth (Page 0028 00-3, item 21) dampened with solvent cleaning compound (Page 0028 00-2, item 7). Dry thoroughly. Remove any rust and corrosion with wire brush (Page 0028 00-1, item 5).</p> | |
| 45 | QUARTERLY | | Burner Assembly | Check burner assembly for fuel leaks, damaged fuel lines, and electrical wiring. Check under boiler for loose fittings. | Any fuel leaks or loose or broken wires. |

OPERATOR'S PREVENTIVE MAINTENANCE CHECKS AND SERVICES (PMCS) – Continued

Table 1. Quarterly and Annual PMCS for M12A1 DED Decontaminating Apparatus - Continued.

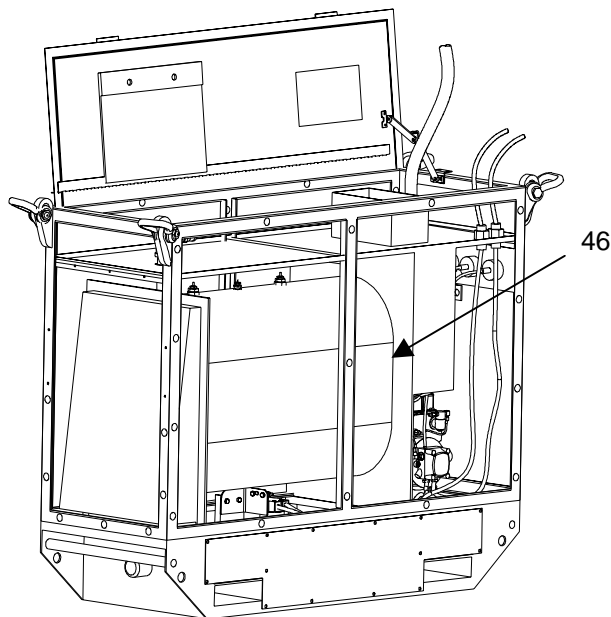

| Item No. | Interval | Man Hour | Item to be Checked/ Serviced | Procedure | Not Fully Mission Capable If: |
|----------|-----------|----------|------------------------------|--|-------------------------------|
| 46 | QUARTERLY | | Low-Pressure Boiler Assembly | <p>a. Inspect for leaks and loose or missing parts, especially around the refractory box end of the boiler.</p> <p>b. Check to see that the exhaust stack screen is not broken, loose, missing, or full of soot.</p> <p>c. Clean all exposed surfaces with hot soapy water. Rinse with clear water. Do not allow water to enter exhaust stack. Remove rust and corrosion with a wire brush (Page 0028 00-1, item 5). Remove soot and foreign matter from spark arrester screen using a wire brush. Touch up surfaces with paint (Page 0028 00-3, item 20) as required.</p> | Screen is broken or missing. |

OPERATOR'S PREVENTIVE MAINTENANCE CHECKS AND SERVICES (PMCS) – Continued

Table 1. Quarterly and Annual PMCS for M12A1 DED Decontaminating Apparatus - Continued.

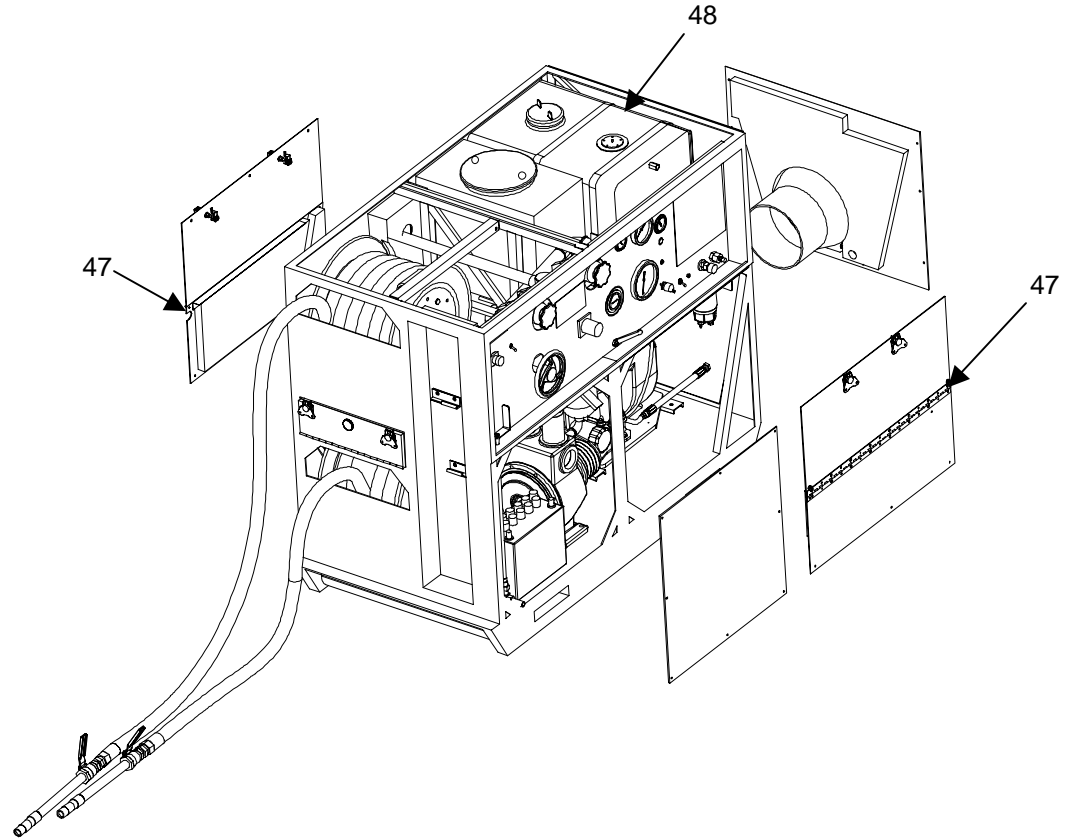

| Item No. | Interval | Man Hour | Item to be Checked/ Serviced | Procedure | Not Fully Mission Capable If: |
|----------|----------|----------|------------------------------|--|-------------------------------|
| 47 | ANNUALLY | | Pump Unit Cover Panels | Lubricate panel hinges using PL-S (Page 0028 00-3, item 19). | |
| 48 | ANNUALLY | | Fuel Tank | Check that fuel tank is tightly mounted to pump unit. If loose, notify Unit Maintenance. | |

END OF WORK PACKAGE

**OPERATOR
M12A1 DIESEL ENGINE DRIVEN DECONTAMINATION APPARATUS
NSN 4230-01-502-7224
LUBRICATION INSTRUCTIONS**

INITIAL SETUP:

Materials/Parts

- Cleaning compound, solvent (Page 0028 00-2, item 7)
- Grease, automotive and artillery (Page 0028 00-2, item 15)
- Lubricating oil, 15W40 (Page 0028 00-2, item 17)
- Lubricating oil, PL-M (Page 0028 00-3, item 18)
- Lubricating oil, PL-S (Page 0028 00-3, item 19)

LUBRICATION INSTRUCTIONS

WARNING

Fire and explosion danger exist when solvent cleaning compound is used. Make sure that equipment is dry before operations begin.

Interval and the related manhour time are based on normal operation. The manhour time specified is the time you need to do all the services. Reduce the interval if your lubricants are contaminated or if you are operating the equipment under adverse operating conditions, including longer-than-usual operating hours. During periods of low operation, the interval may be extended if the preservation steps of Note 11 are followed. Lubrication points, intervals, and lubricants are listed below. Clean fittings, valve stems, and pipe threads with solvent cleaning compound (Page 0028 00-2, item 7). Dry before lubricating. Do not overlubricate; wipe off excess lubricant.

| Total Man-Hours | |
|-----------------|--------|
| Interval | Man-Hr |
| Q | 0.80 |

LUBRICANT INTERVAL

| | | |
|-----|---|---|
| GAA | Q | Tank Unit (1 fitting on tank drain valve) (See note 2, 5, & 9) |
| GAA | Q | Personnel Shower Assembly Threads (See note 8) |

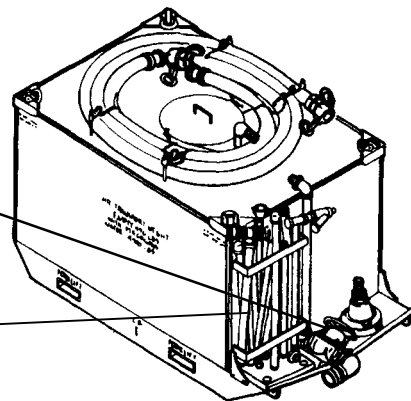

LUBRICATION INSTRUCTIONS – Continued

LUBRICANT INTERVAL

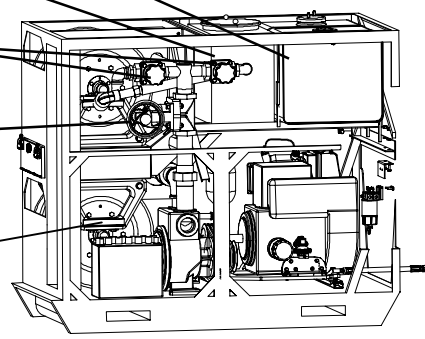
| | | | |
|-----|---|---|--|
| | | Fuel Tank (See note 10) |  |
| GAA | Q | Prime and Detergent Tank (See note 10) Valve Nos. 2 and 3 (See note 2) | |
| GAA | Q | Valve No. 1 and Beveled Gear Train (See notes 2 and 5) | |
| GAA | Q | Hose Reel Swivel Joint (4 fittings) (See note 5) | |

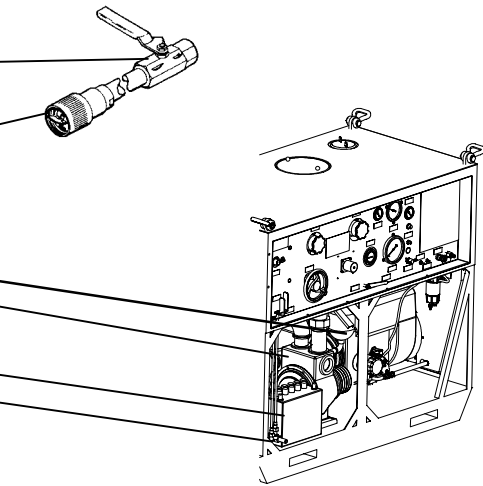
| | | | |
|------|---|--|---|
| PL-S | Q | Gun Assemblies (See note 3) |  |
| PL-S | Q | Slurry Nozzles (See note 3) | |
| GAA | Q | Engine (See note 6) Pump (1 fitting; see notes 5, 7, and 11) | |
| PL-S | Q | Battery (See note 12) Pump Drain (No. 4 valve) | |

Q Operate engine and pump for at least 30 seconds immediately after lubrication to distribute lubricants. During operation rotate all valves to lubricate diaphragms and bell valves.

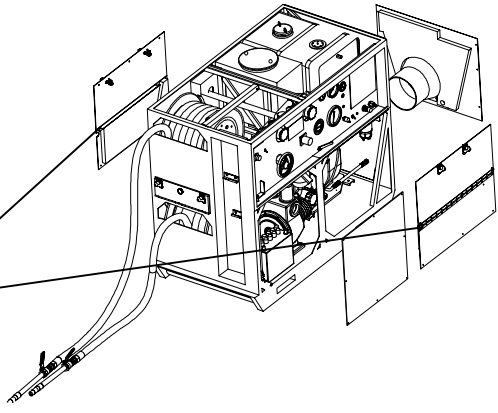
| | | | |
|------|---|-------------------------------|--|
| PL-S | Q | Panel hinges (See note 13) |  |
|------|---|-------------------------------|--|

LUBRICATION INSTRUCTIONS – Continued

LUBRICANT INTERVAL

PL-S Q Heater Top Cover Hinge
(See note 13)

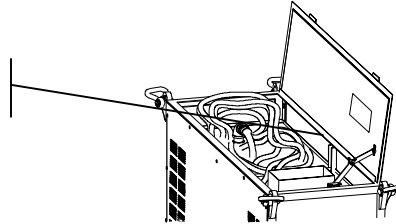

| LUBRICANTS | | EXPECTED TEMPERATURE | | | INTERVALS |
|--------------------------|---|---|----------------|--------------|-----------------------------------|
| | | Above +32°F | +40°F to -10°F | 0°F to -65°F | |
| PL-M (MIL-L-3150) | Lubricating Oil Preservative Medium NSN 9150-00-231-2361 | PL-M | PL-M | | See notes 4, 10, and 11 |
| PL-S (VV-L-800) | Lubricating Oil General Purpose Preservative (Water- Displacing, Low Temperature) NSN 9150-00-231-6689 (1 qt can) | PL-S | PL-S | PL-S | See notes 3, 4, 10, 11, and 13 |
| GAA (MIL-G-10924) | Grease, Automotive and Artillery NSN 9150-00-190-0905 (5 lb can) | GAA All temperature except in tropical climates. Use GTH (Lubrication Grease High Temperature Electric Motor Ball and Roller Bearings) (MIL-L-15719) NSN 9150- 00-257-5358) (8 oz tube) | | | See notes 2, 5, 8, 9, and 12 |
| 15W40 (MIL-PRF-2104G) | Lubricating Oil NSN 9150-01-438-6076 | | | | See note 6 |

NOTES:

1. CARE OF LUBRICANT -- See that lubricant containers are closed tightly to prevent contamination when not in use.
2. VALVES -- Clean and dry. Coat stems with GAA.
3. NOZZLES and GUN -- Clean and dry. Lightly coat with PL-S.
4. END OF SPRAYING MISSION -- Circulate 3 gallons water and 3 pints PL-M or PL-S through pump, according to note 11.
5. FITTINGS -- Apply grease (one stroke of handgun or equivalent) to lubrication fittings. Excess lubrication will damage seals. If hose reel assembly pillow blocks have grease fittings, grease the fittings quarterly with GAA.
6. DIESEL ENGINE – Lubricate with 15W40 lubricating oil (Page 0028 00-2, item 17).
7. PUMP -- Unscrew pump breather from bearing housing before applying grease to fitting. After lubrication, wipe off all excess grease and reinstall pump breather.
8. DUST CAPS and THREADED PARTS -- Coat all threaded parts with GAA whenever they are disassembled.
9. FOOT VALVE and SHOWER PIPING -- Clean and dry. Coat threaded parts with GAA.

LUBRICATION INSTRUCTIONS – Continued

NOTES: – Continued

10. **DETERGENT and FUEL TANKS** -- During inactive periods, fog interior of prime and detergent tank and fuel tank with PL-M or PL-S.
11. **IDLE TIME** -- If the apparatus is to be idle for greater than 24 hours, lubricate the pump by pouring 3 pints of PL-M or PL-S mixed with 3 gallons of water into the prime detergent tank. Open valve No. 4 and allow the mixture to run into the pump. Start the pump unit and operate for 30 seconds. Stop the pump unit. Open the pump drain valve and allow the mixture to run out. Check that prime detergent tank is empty. Close the pump drain valve and valve no. 4. For idle time greater than 48 hours, follow the above procedures and, in addition, wipe exterior surfaces of pump, piping, and valves with a cloth dampened with PL-M or PL-S.
12. Coat battery terminals with GAA.
13. **HINGED PANELS** -- Lubricate hinges with PL-S.

END OF WORK PACKAGE

**OPERATOR
M12A1 DIESEL ENGINE DRIVEN DECONTAMINATION APPARATUS
NSN 4230-01-502-7224
PERSONNEL SECTIONAL SHOWER MAINTENANCE INSTRUCTIONS
REPAIR**

INITIAL SETUP:

Materials/Parts

Gasket (B5-45-3130-1)

REPAIR

1. Check and replace gaskets in the couplings, as required. Gaskets are 1-1/2 inches in diameter (Page 0027 00-2, item 3).

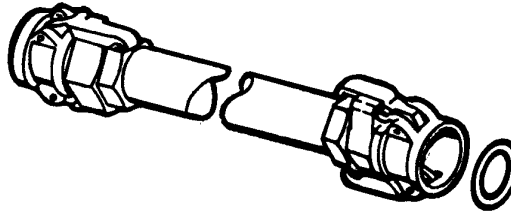

END OF WORK PACKAGE

**OPERATOR
M12A1 DIESEL ENGINE DRIVEN DECONTAMINATION APPARATUS
NSN 4230-01-502-7224
GUN ASSEMBLY MAINTENANCE INSTRUCTIONS
REPAIR**

INITIAL SETUP:**Materials/Parts**

Gasket (B5-45-2635)
Gasket (B5-45-2934)
Nozzle assembly, slurry (C5-45-2700)
Nozzle, fire hose, foam (C5-45-2701)
Nozzle, fire hose, water (C5-45-2699)

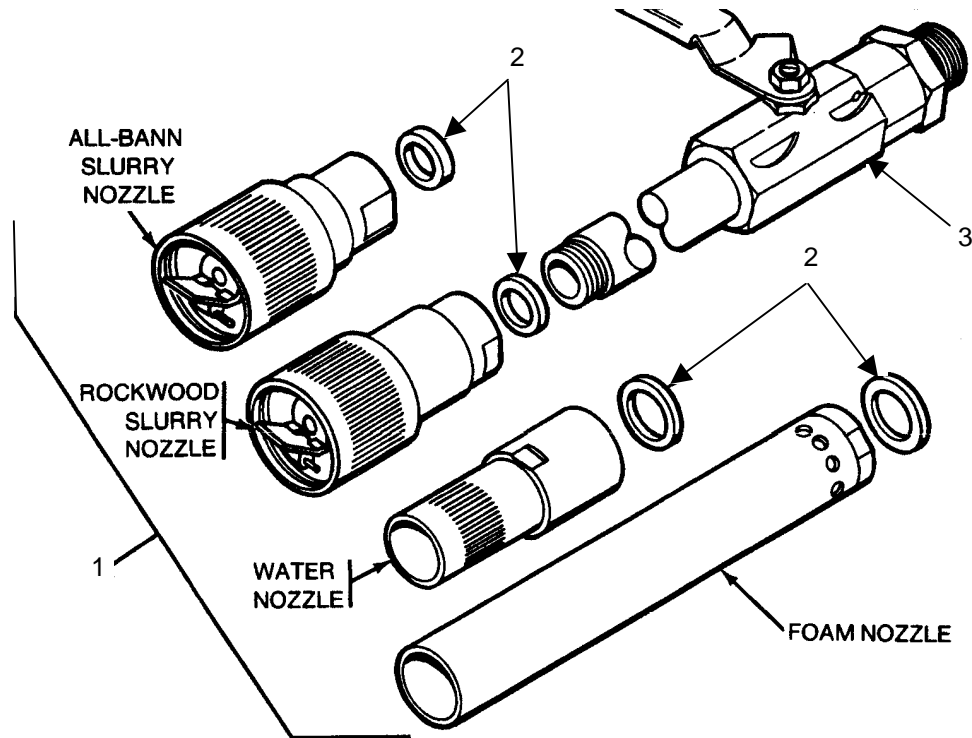
REPAIR**NOTE**

Use the following instructions to replace slurry nozzle, water nozzle or foam nozzle and unserviceable gasket.

1. Remove nozzle (1) and 1-inch diameter gasket (2) from extension pipe (3).
2. Place 1-inch-diameter gasket (B5-45-2934) (2) into seat in threaded end of nozzle (1).
3. Install nozzle (1) on extension pipe (3). Do not overtighten.

REPAIR - Continued

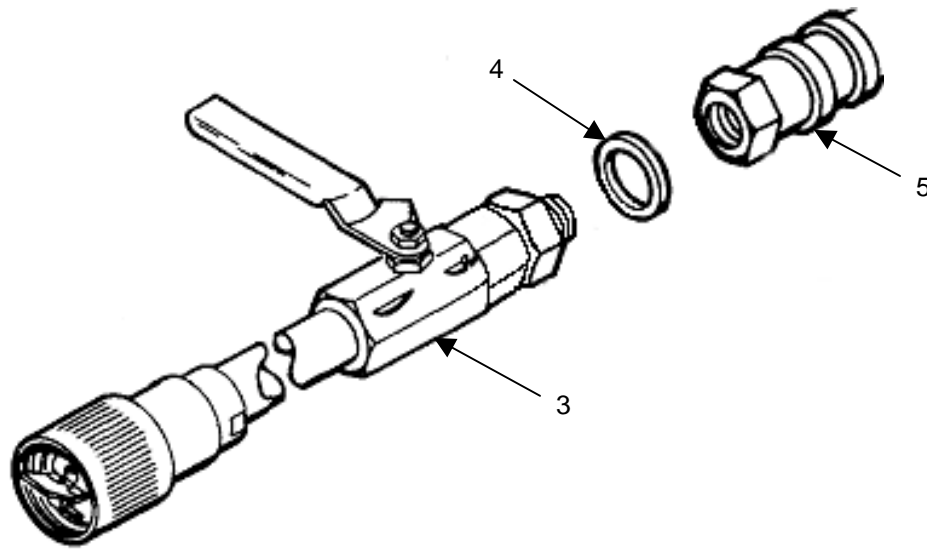

4. Install gun assembly on the discharge hose as follows:

- a. Install 1-inch gasket (B5-45-2635) (4) on hose coupling (5).
- b. Connect hose coupling (5) to gun assembly (3).
- c. Using two adjustable wrenches, tighten hose coupling (5) on gun assembly (3). Do not overtighten.

END OF WORK PACKAGE

**OPERATOR
M12A1 DIESEL ENGINE DRIVEN DECONTAMINATION APPARATUS
NSN 4230-01-502-7224
PUMP UNIT SUBASSEMBLY MAINTENANCE INSTRUCTIONS
DRIVE BELT TENSION INSPECTION**

INITIAL SETUP:

DRIVE BELT TENSION INSPECTION

WARNING

Avoid contact with the battery's positive connection at the starter solenoid when adjusting the belt tension. Electrical shock, fire, or damage to the equipment may result.

NOTE

Check the alternator belt after the first 15 hours of operation. Check the water pump belts and alternator belt at 50 hours of operation.

Pump Drive Belt Tension Inspection

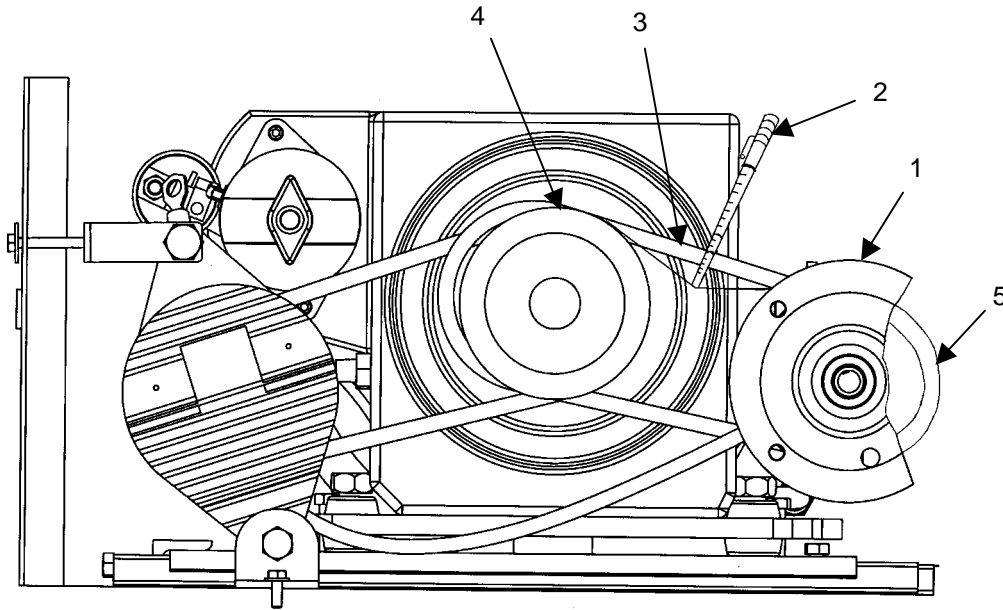

1. Check pump (1) belt tension using tensiometer (2), which can be found in the tool box.
2. Set the O-ring on the small end of tensiometer (2) at the 3/8-inch mark and set the other O-ring against the outer movable surface of the tensiometer.
3. Place the small end of tensiometer (2) against one of the four drive belts (3) at a point halfway between drive pulley (4) and driven pulley (5).
4. Press down on the drive belt (3) until the O-ring at the 3/8-inch mark touches against an adjacent drive belt (3).

DRIVE BELT TENSION INSPECTION - Continued**Pump Drive Belt Tension Inspection - Continued**

5. Withdraw tensiometer (2) and read the indication of the second O-ring, which was moved along the scale by the amount of pressure applied. The indication should be between 5 and 7 pounds.
6. If the tension is unsatisfactory, notify Unit Maintenance.

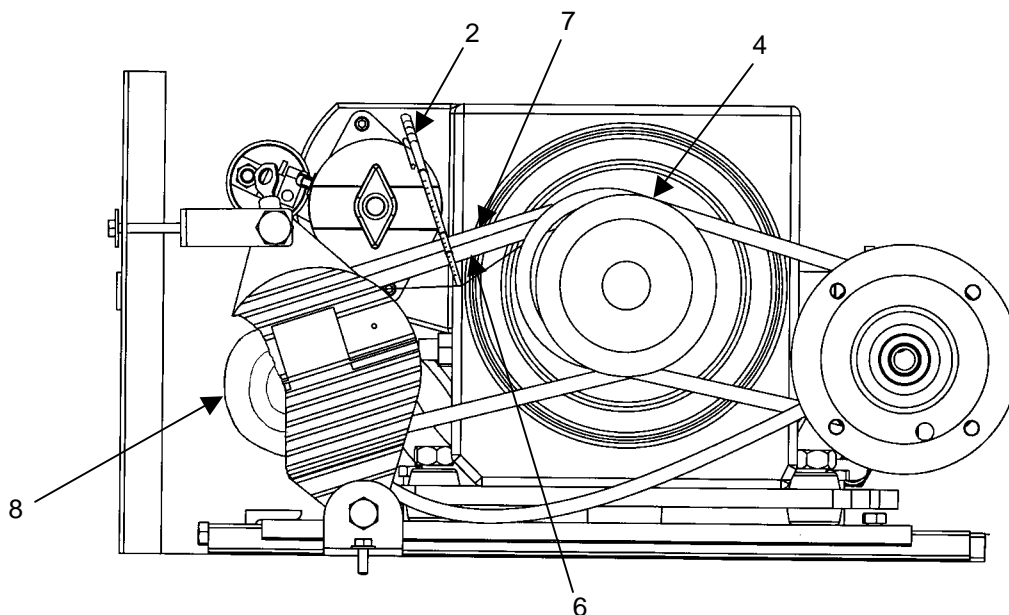
Alternator Drive Belt Tension Inspection

1. Check the alternator belt (6) tension by using the tensiometer (2).
2. Set the O-ring on the small end of tensiometer (2) at the 3/8-inch mark and set the other O-ring against the outer movable surface of the tensiometer.
3. Lay a straightedge (7) between the two pulleys (4 and 8) along the top edge of alternator belt (6).
4. Press down on alternator belt (6) with tensiometer (2) until the O-ring at the 3/8-inch mark touches straightedge (7).
5. Withdraw tensiometer (2) and read the indication on the second O-ring which was moved along the scale by the amount of pressure applied. The indication should be between 5 and 7 pounds.
6. If the tension is unsatisfactory, notify Unit Maintenance.

END OF WORK PACKAGE

OPERATOR
M12A1 DIESEL ENGINE DRIVEN DECONTAMINATION APPARATUS
NSN 4230-01-502-7224
ENGINE AIR FILTER ELEMENT MAINTENANCE INSTRUCTIONS
REMOVAL, CLEANING, INSTALLATION

INITIAL SETUP:

REMOVAL

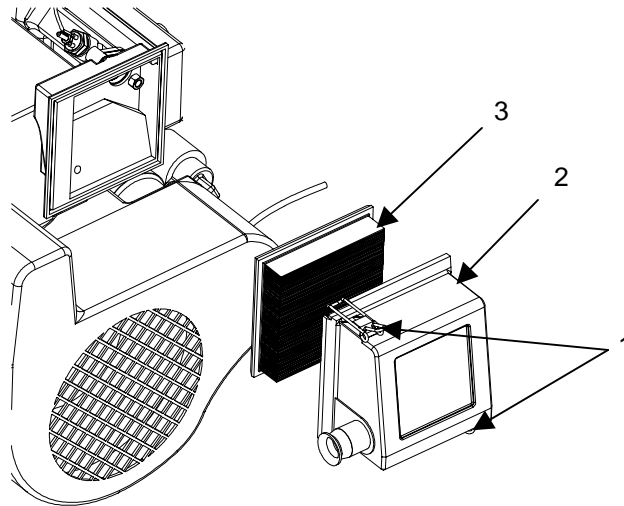

1. Pull clips (1) and remove air filter cover (2).

NOTE

Check and clean air filter element more frequently if system is operated in a dusty environment.

2. Remove air filter element (3).

CLEANING

CAUTION

Do not clean air filter element with high-pressure air.

1. Tap air filter element (3) on solid surface to dislodge any foreign material. Hold air filter element up to the light and ensure that light comes through air filter element. If light does not come through air filter element or air filter element is damaged or wet, notify Unit Maintenance.

INSTALLATION

1. Position air filter element (3) into air filter cover (2).
2. Install air filter cover (2) and set clips (1) to secure.

END OF WORK PACKAGE

**OPERATOR
M12A1 DIESEL ENGINE DRIVEN DECONTAMINATION APPARATUS
NSN 4230-01-502-7224
STARTER MAINTENANCE INSTRUCTIONS
INSPECTION AND CLEANING**

INITIAL SETUP:**Tools and Special Tools**

Wire brush (Page 0028 00-1, item 5)

WARNING

Disconnect the NEGATIVE (NEG) terminal of the battery assembly prior to disconnecting or connecting the electrical starter cable. Failure to do so could cause electrical shock and severe damage to the system.

Remove all jewelry before starting work. Metal objects such as rings or tools can cause short circuits. Do not allow tools to contact live circuits. A direct short can cause instant heating of tools resulting in equipment damage and personnel burns. Failure to comply may result in personal injury.

Wear eye protection and protective gloves when working with batteries. If battery acid splashes on face or into eyes, flush with clean water and get immediate medical treatment. If acid gets on skin, wash with soap and water. If skin irritation, rash, or eye redness occurs, get medical attention. Failure to comply may result in burns or blindness.

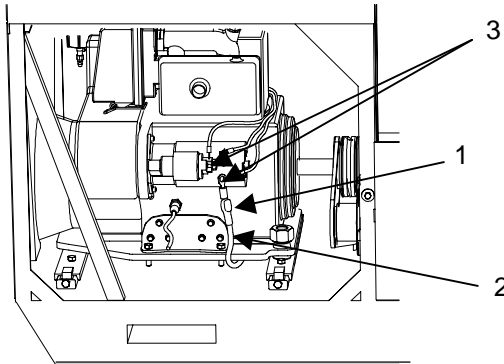
INSPECTION

1. Pull back on rubber boot (1) covering starter cable (2).
2. Inspect starter cable terminals (3) for corrosion or loose connections.

CLEANING

1. To clean corrosion from starter terminal(s), disconnect NEG battery terminal, loosen nut(s) on terminal(s) and remove starter cable. Use wire brush (Page 0028 00-1, item 5) to remove corrosion.
2. Reattach starter cable and securely tighten starter cable nut(s). Attach NEG battery terminal.

END OF WORK PACKAGE

CHAPTER 5

SUPPORTING INFORMATION
FOR
M12A1 DIESEL ENGINE-DRIVEN DECONTAMINATING APPARATUS

**OPERATOR
M12A1 DIESEL ENGINE DRIVEN DECONTAMINATION APPARATUS
NSN 4230-01-502-7224
REFERENCES**

SCOPE

This appendix lists all forms, field manuals, technical manuals and miscellaneous publications referenced in this manual.

FIELD MANUALS

- FM 3-11.5 NBC Decontamination
- FM 4-25.11 First Aid for Soldiers

TECHNICAL MANUALS

- TM 3-4240-300-10..... Operator's Manual: Mask, Chemical-Biological: Field M40A1 and Accessories
- TM 9-6140-200-14..... Operator's, Organizational, Direct Support, and General Support Maintenance Manual for Lead-Acid Storage Batteries:
4HN, 24 Volt (6140-00-059-3528) MS75047-1
2HN, 12 Volt (6140-00-057-2553) MS35000-1
6TN, 12 Volt (6140-00-057-2554) MS35000-3

MISCELLANEOUS PUBLICATIONS

- DA PAM 738-750..... The Army Maintenance Management System (TAMMS)

FORMS

- CTA 8-100 Army Medical Department Expendable/Durable Items
- CTA 50-970 Expendable/Durable Items (except Medical, Class V, Repair Parts, and Heraldic Items)
- DA Form 2028 Recommended Changes to Publications and Blank Forms
- DA Form 2404/5988E..... Equipment Inspection and Maintenance Worksheet
- SF 368 Quality Deficiency Report

END OF WORK PACKAGE

**OPERATOR
M12A1 DIESEL ENGINE DRIVEN DECONTAMINATION APPARATUS
NSN 4230-01-502-7224
COMPONENTS OF END ITEM (COEI) AND BASIC ISSUE ITEMS (BII) LISTS**

INTRODUCTION

Scope

This work package lists COEI and BII for the M12A1 DED Decontaminating Apparatus to help you inventory items for safe and efficient operation of the equipment.

General

The COEI and BII information is divided into the following lists:

Components of End Item (COEI). This list is for information purposes only and is not authority to requisition replacements. These items are part of the M12A1 DED Decontaminating Apparatus. As part of the end item, these items must be with the end item whenever it is issued or transferred between property accounts. Items of COEI are removed and separately packaged for transportation or shipment only when necessary. Illustrations are furnished to help you find and identify the items.

Basic Issue Items (BII). These essential items are required to place the M12A1 DED Decontaminating Apparatus in operation, operate it, and to do emergency repairs. Although shipped separately packaged, BII must be with the M12A1 DED Decontamination Apparatus during operation and when it is transferred between property accounts. Listing these items is your authority to request/requisition them for replacement based on authorization of the end item by TOE/MTOE. Illustrations are furnished to help you find and identify the items.

Explanation of Columns in the COEI List and BII List

Column (1) Illus Number. Gives you the number of the item illustrated.

Column (2) National Stock Number (NSN). Identifies the stock number of the item to be used for requisitioning purposes.

Column (3) Description, CAGEC, and Part Number. Identifies the Federal item name (in all capital letters) followed by a minimum description when needed. The stowage location of COEI and BII is also included in this column. The last line below the description is the CAGEC (Commercial and Government Entity Code) (in parentheses) and the part number.

Column (4) Usable On Code. When applicable, gives you a code if the item you need is not the same for different models of equipment.

Column (5) Unit of Issue (U/I). Indicates the physical measurement or count of the item as issued per the National Stock Number shown in column (2).

Column (6) Qty Rqr. Indicates the quantity required.

COMPONENTS OF END ITEM (COEI) AND BASIC ISSUE ITEMS (BII) LISTS

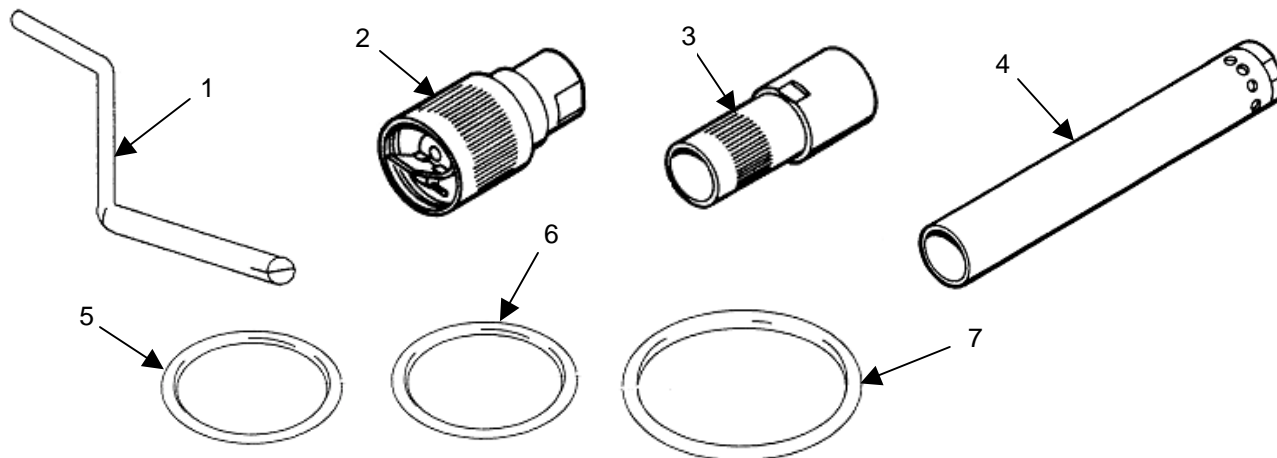

Table 1. Components of End Item List.

| (1) ILLUS NUMBER | (2) NATIONAL STOCK NUMBER | (3) DESCRIPTION, CAGEC, AND PART NUMBER | (4) USABLE ON CODE | (5) U/I | (6) QTY RQR |
|----------------------------|------------------------------------|---|--------------------------|------------|-------------------|
| COMPONENTS OF THE END ITEM | | | | | |
| 1 | 5340-00-944-6089 | CRANK, HAND (in tool box on pump unit) (81361) 5-45-3342 | | EA | 1 |
| 2 | 4730-00-816-5589 | NOZZLE ASSEMBLY, SLURRY (in tool box on pump unit) (81361) C5-45-2700 | | EA | 2 |
| 3 | 4210-00-809-4862 | NOZZLE, FIRE HOSE, WATER (in tool box on pump unit) (81361) C5-45-2699 | | EA | 2 |
| 4 | 4210-00-816-5585 | NOZZLE, FIRE HOSE, FOAM (in tool box on pump unit) (81361) C5-45-2701 | | EA | 2 |
| ON-BOARD SPARES | | | | | |
| 5 | 5330-00-811-9471 | GASKET, 1-inch diameter (in tool box on pump unit) (81361) B5-45-2635 | | EA | 4 |
| 6 | 5330-00-811-9472 | GASKET, 1-inch diameter (in tool box on pump unit) (81361) B5-45-2934 | | EA | 3 |
| 7 | 5330-00-787-7417 | GASKET, 1-1/2-inch diameter (in tool box on pump unit) (81361) B5-45-3130-1 | | EA | 5 |

COMPONENTS OF END ITEM (COEI) AND BASIC ISSUE ITEMS (BII) LISTS - Continued

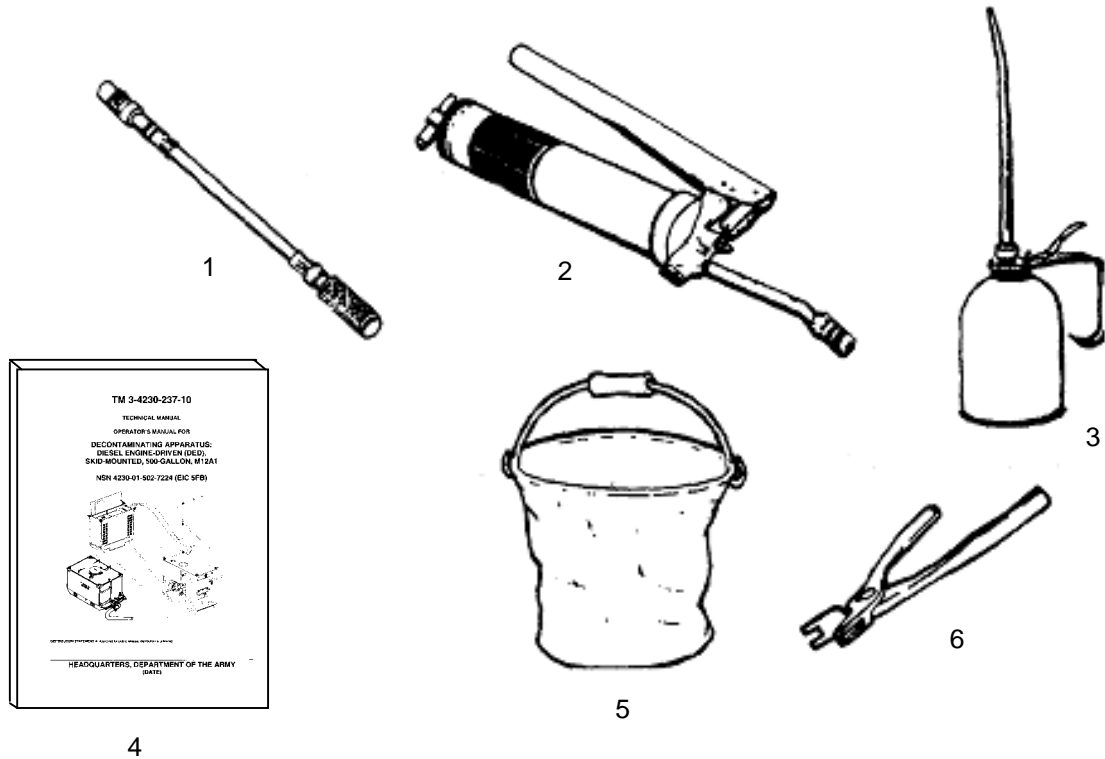

Table 2. Basic Issue Items List.

| (1) ILLUS NUMBER | (2) NATIONAL STOCK NUMBER | (3) DESCRIPTION, CAGEC, AND PART NUMBER | (4) USABLE ON CODE | (5) U/I | (6) QTY RQR |
|------------------------|------------------------------------|--|--------------------------|------------|-------------------|
| 1 | 4930-00-288-1511 | ADAPTER, GREASE GUN COUPLING, FLEXIBLE 12 IN. LG, (81349) MILL4387 TYPE 4, CLASS 1, SIZE B | | EA | 1 |
| 2 | 4930-00-253-2478 | GUN, HAND, GREASE (81349) MILG3859 TYPE 1 | | EA | 1 |
| 3 | 4930-00-274-5713 | OILER, HAND (96906) MS15762-1 | | EA | 1 |
| 4 | | TM 3-4230-237-10 Operator's Manual for Decontaminating Apparatus, Diesel Engine Driven (DED), Skid Mounted, 500 Gallon, M12A1 | | EA | 1 |
| 5 | 8465-00-128-6928 | PAIL COLLAPSIBLE, NYLON (54212) | | EA | 1 |
| 6 | 5120-00-321-4507 | PLIERS, CAMLOC (71286) 4P3 | | EA | 1 |

COMPONENTS OF END ITEM (COEI) AND BASIC ISSUE ITEMS (BII) LISTS - Continued

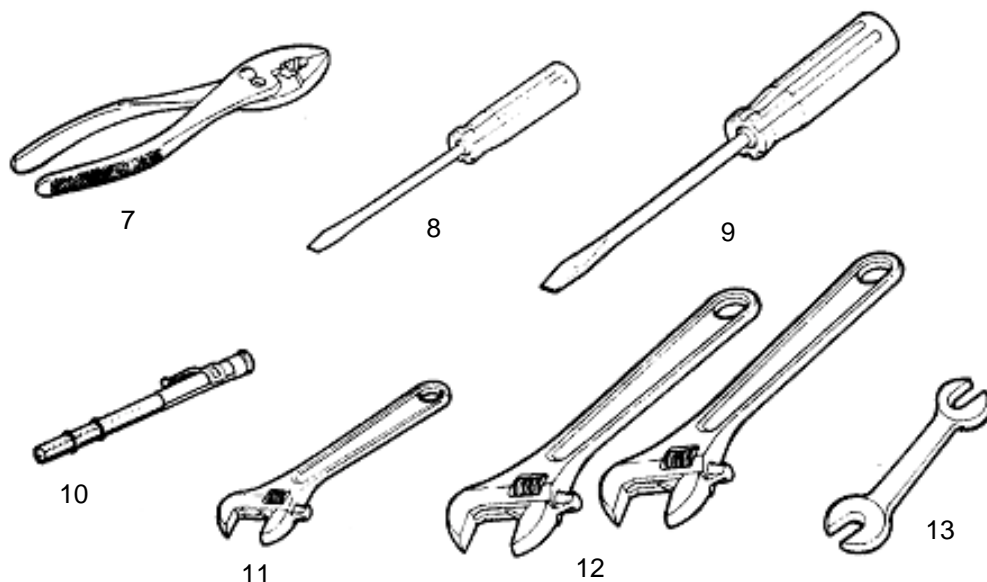

Table 2. Basic Issue Items List - Continued.

| (1) ILLUS NUMBER | (2) NATIONAL STOCK NUMBER | (3) DESCRIPTION, CAGEC, AND PART NUMBER | (4) USABLE ON CODE | (5) U/I | (6) QTY RQR |
|------------------------|------------------------------------|--|--------------------------|------------|-------------------|
| 7 | 5120-00-223-7396 | PLIERS, SLIP JOINT, STRAIGHT NOSE COMB. 6 IN. TYPE 2, STYLE A, CLASS 2 (93389) 276 | | EA | 1 |
| 8 | 5120-00-062-0813 | SCREWDRIVER, FLAT TIP, 6 IN. (96508) R3166-6 | | EA | 1 |
| 9 | 5120-01-376-3746 | SCREWDRIVER, FLAT TIP, 8 IN. (55719) SG08 | | EA | 1 |
| 10 | 6635-00-921-6255 | TENSIOMETER, V-BELT (24161) 12998F | | EA | 1 |
| 11 | 5120-00-240-5328 | WRENCH, OPEN END, ADJ: 8 IN. (19207) 11655778-3 | | EA | 1 |
| 12 | 5120-00-423-6728 | WRENCH, OPEN END, ADJ: 15 IN. (19207) 6187328 | | EA | 2 |
| 13 | 5120-00-187-7126 | WRENCH, OPEN END, FIXED: 9/16 IN. AND 5/8 IN. (19207) 11655789-2 | | EA | 1 |

END OF WORK PACKAGE

**OPERATOR
M12A1 DIESEL ENGINE DRIVEN DECONTAMINATION APPARATUS
NSN 4230-01-502-7224
EXPENDABLE AND DURABLE ITEMS**

INTRODUCTION

Scope

This work package lists expendable and durable items that you will need to operate and maintain the M12A1 DED Decontaminating Apparatus. This list is for information only and is not authority to requisition the listed items. These items are authorized to you by CTA 50-970, Expendable/Durable Items (Except Medical, Class V Repair Parts, and Heraldic Items), or CTA 8-100, Army Medical Department Expendable/Durable Items.

Explanation of Columns in the Expendable/Durable Items List

Column (1) Item Number. This number is assigned to the entry in the list and is referenced in the narrative instructions to identify the item (e.g., "Use brake fluid (item 5, WP 0098 00).").

Column (2) Level. This column identifies the lowest level of maintenance that requires the listed item.
C = Operator/Crew

Column (3) National Stock Number (NSN). This is the NSN assigned to the item which you can use to requisition it.

Column (4) Item Name, Description, Commercial and Government Entity Code (CAGEC), and Part Number (P/N). This column provides the other information you need to identify the item.

Column (5) Unit of Issue (U/I). Indicates the physical measurement or count of the item as issued per the National Stock Number shown in column (3).

EXPENDABLE AND DURABLE ITEMS LIST

Table 2. Expendable and Durable Items List.

| (1) ITEM NUMBER | (2) LEVEL | (3) NATIONAL STOCK NUMBER | (4) ITEM NAME, DESCRIPTION, CAGEC, AND PART NUMBER | (5) U/I |
|-----------------------|--------------|------------------------------------|--|------------|
| 1 | C | 6850-00-950-6489 | ANTIFOAM COMPOUND, SILICONE (71984) ANTIFOAM B 5 gal can | GL |
| 2 | C | 6850-00-656-0926 | ANTISETTING COMPOUND DECONTAMINATING SLURRY (81349) MILA51027 12-1/2 lb drum | LB |
| 3 | C | 7920-00-255-7536 | BRUSH, CHASSIS AND RUNNING GEAR (81348) H-B-181 | EA |
| 4 | C | 8020-00-205-6511 | BRUSH, PAINT, 1 IN. (81348) H-B-491 | EA |
| 5 | C | 7920-00-291-5815 | BRUSH, WIRE, SCRATCH TYPE 2, class 1 (81348) H-B-178 | EA |

EXPENDABLE AND DURABLE ITEMS LIST - Continued

Table 2. Expendable and Durable Items List - Continued.

| (1) ITEM NUMBER | (2) LEVEL | (3) NATIONAL STOCK NUMBER | (4) ITEM NAME, DESCRIPTION, CAGEC, AND PART NUMBER | (5) U/I |
|-----------------------|--------------|------------------------------------|---|------------|
| 6 | C | 6810-00-255-0472 | CALCIUM HYPOCHLORITE TECHNICAL (81438) O-C-114 100 lb drum | LB |
| 7 | C | 6850-01-378-0679 | CLEANING COMPOUND, SOLVENT (OK209) Breakthrough 5 gal can | GL |
| 8 | C | 6850-00-297-6653 | DECONTAMINATING AGENT STB (81349) MIL-D-12468 50 lb drum | LB |
| 9 | C | 7930-00-985-6911 | DETERGENT, GENERAL PURPOSE liquid form (77902) TRITONX 100 5 gal can | GL |
| 10 | C | 9140-00-286-5294 | DIESEL FUEL grade DF-2 (81348) VVF800GRADED2RE | GL |
| 11 | C | 9140-00-286-5283 | DIESEL FUEL arctic grade (81348) VVF800GRADEDFAAR | GL |
| 12 | C | 8010-00-286-7758 | ENAMEL YELLOW NO. 13538 (81349) TT-E-489G 1 qt can | QT |
| 13 | C | 4210-01-056-8343 | FOAM LIQUID, FIRE EXTINGUISHING (81349) MIL-F-24385 5 gal can | GL |
| 14 | C | 8415-00-823-7457 | GLOVES, CHEMICAL AND OIL PROTECTIVE (81348) ZZ-G-381 | PR |
| 15 | C | 9150-00-190-0905 | GREASE, AUTOMOTIVE AND ARTILLERY (81349) BRAYCOTE 610 6.5 lb can | LB |
| 16 | C | 9150-00-186-6681 | LUBRICATING OIL: 30 wt (81349) MIL-L-2104 | QT |
| 17 | C | 9150-01-438-6076 | LUBRICATING OIL: 15W40 (81349) MIL-PRF-2104G | QT |

EXPENDABLE AND DURABLE ITEMS LIST - Continued

Table 2. Expendable and Durable Items List - Continued.

| (1) ITEM NUMBER | (2) LEVEL | (3) NATIONAL STOCK NUMBER | (4) ITEM NAME, DESCRIPTION, CAGEC, AND PART NUMBER | (5) U/I |
|-----------------------|--------------|------------------------------------|---|------------|
| 18 | C | 9150-00-231-2361 | LUBRICATING OIL, GENERAL PURPOSE, PL-M (19203) 814370 1 qt can | QT |
| 19 | C | 9150-00-231-6689 | LUBRICATING OIL, GENERAL PURPOSE, PL-S (19204) 14-0-2834-10 1 qt can | QT |
| 20 | C | 8010-01-160-6741 | POLYURETHANE COATING (GREEN 383) (81349) MIL-C-46168B 1 qt kit | QT |
| 21 | C | 7920-00-205-1711 | RAG, WIPING: cotton (58536) AA-A-531 50 lb bale | EA |
| 22 | C | 6810-00-264-6618 | SODIUM BICARBONATE, TECHNICAL POWDER FORM (81348) O-S-576 1 lb box | LB |
| 23 | C | 6810-00-233-1715 | SODIUM CARBONATE (81348) 05571 100 lb bag | LB |
| 24 | C | 6810-00-174-6581 | SODIUM HYDROXIDE, TECHNICAL flake form (70829) 1308 100 lb drum | LB |
| 25 | C | 5970-00-419-4290 | TAPE, INSULATION, ELECTRICAL black plastic (20999) 7-1/2 INBLACK 108 ft roll | FT |
| 26 | C | 7510-00-816-8077 | TAPE, PRESSURE SENSITIVE (81348) L-T-80 3 in. wide, 6 yd roll | YD |
| 27 | C | 9130-01-031-5816 | TURBINE FUEL, AVIATION (81349) MILT83113 Grade JP-8 | GL |

END OF WORK PACKAGE

ALPHABETICAL INDEX

| <u>Subject</u> | <u>WP Sequence No.-Page No.</u> |
|---|--|
| A | |
| Air Filter Assembly | 0016 00-13 0019 00-13 |
| Alternator Assembly | 0016 00-14 0019 00-14 |
| B | |
| Basic Issue Items | 0027 00-1 |
| Battery | 0016 00-5 0019 00-4 |
| Blender Hose Assembly | 0016 00-16 0017 00-5 0019 00-16 |
| Burner Assembly | 0016 00-21 0018 00-9 0019 00-23 |
| C | |
| Cabinet Top Cover..... | 0019 00-19 |
| Centrifugal Pump..... | 0016 00-11 0018 00-4 0019 00-11 |
| Chemical Protective Clothing..... | 0008 00-1 |
| Cleaning and Storage Procedures After a Spraying Mission..... | 0011 00-1 |
| Clevis and Eyebolt Assemblies | 0019 00-3 |
| Clothing, Protective | 0008 00-1 |
| Components of End Item | 0027 00-2 |
| Connector Panel..... | 0016 00-10 0019 00-9 |
| Control Box Assembly | 0016 00-18 0017 00-6 0018 00-8 0019 00-21 |
| Control Panel Assembly | 0016 00-15 0017 00-4 |
| Cover Panels | |
| Water Heater..... | 0019 00-20 0019 00-24 |
| Pump Unit..... | 0016 00-5 0018 00-3 0019 00-3 0019 00-25 |
| D | |
| Decals and Instruction Plates, Operating Instructions | 0010 00-1 |
| Description and Use of Operator's Controls and Indicators | 0004 00-1 |
| Discharge Hose Assemblies | 0016 00-6 0017 00-2 0019 00-6 |

| <u>Subject</u> | <u>WP Sequence No.-Page No.</u> |
|--|---|
| D (Cont) | |
| Drain Valve, Tank..... | 0016 00-17 0017 00-5 0019 00-17 |
| Drive Belts | 0016 00-10 0018 00-4 |
| Drive Belt Tension Inspection | 0023 00-1 |
| E | |
| Eductor Hose Assembly..... | 0016 00-6 0019 00-6 |
| Engine Air Filter Element | 0024 00-1 |
| Engine and Pump Unit Canvas Protective Cover..... | 0018 00-2 0019 00-3 |
| Engine Assembly | 0016 00-13 0019 00-13 |
| Engine Oil and Oil Filter..... | 0016 00-13 0019 00-13 |
| Equipment Characteristics, Capabilities and Features | 0002 00-1 |
| Equipment Data | 0002 00-5 |
| Expendable/Durable Supplies and Materials | 0028 00-1 0019 00-12 |
| F | |
| Fabricated Lines..... | 0016 00-18 0018 00-10 0019 00-21 |
| Foot Valve Assembly..... | 0016 00-17 0018 00-7 0019 00-17 |
| Frame Assembly | 0019 00-9 |
| Fuel Filter..... | 0016 00-6 0018 00-3 0018 00-6 |
| Fuel Hose | 0016 00-14 0016 00-20 0017 00-7 0019 00-14 0019 00-22 |
| Fuel Filter..... | 0016 00-19 0018 00-5 0018 00-9 |
| FUEL INDICATOR | 0016 00-9 |
| Fueling | 0005 00-1 |
| Fuel Pump | 0018 00-10 |
| Fuel Pump and Blower Motor..... | 0016 00-21 0019 00-23 |
| Fuel Tank | 0016 00-7 0017 00-2 0019 00-7 0019 00-25 |
| G | |
| General Cleaning Instructions..... | 0016 00-1 |
| Gun Assembly..... | 0016 00-6 0019 00-5 0022 00-1 |

Subject

WP Sequence No.-Page No.

H

| | |
|--|------------|
| Heating Water..... | 0007 00-7 |
| Heating Water Drawn from a Natural Source..... | 0007 00-11 |
| Heating Water from the Tank..... | 0007 00-12 |
| Heating Water in the Tank..... | 0009 00-7 |
| Hopper Assembly | 0016 00-16 |
| | 0018 00-7 |
| | 0019 00-16 |
| Hose Assemblies..... | 0016 00-16 |
| | 0016 00-20 |
| | 0017 00-2 |
| | 0017 00-5 |
| | 0019 00-16 |
| Hose Reels..... | 0016 00-10 |
| | 0019 00-9 |
| How to Use This Manual..... | iii |

L

| | |
|---|------------|
| Liquid Fuel Water Heater | 0016 00-16 |
| | 0017 00-6 |
| | 0019 00-17 |
| Loading Tank from a Natural Source | 0007 00-5 |
| Loading Tank from a Pressure Source..... | 0007 00-4 |
| Location and Description of Major Components..... | 0002 00-1 |
| LOW OIL PRESSURE LIGHT..... | 0018 00-6 |
| Low Pressure Boiler Assembly | 0016 00-21 |
| | 0017 00-7 |
| | 0019 00-24 |
| Lubrication Instructions..... | 0020 00-1 |

M

| | |
|---|------------|
| M12A1 DED Decontaminating Apparatus..... | 0018 00-1 |
| | 0019 00-1 |
| Maintenance Forms and Records..... | 0001 00-1 |
| Making STB Decontaminating Agent Slurry | 0008 00-1 |
| Mixing Chemicals Other Than STB in Tank..... | 0008 00-7 |
| Mixing Water and Liquid Chemicals Using the Prime-Detergent Tank..... | 0008 00-20 |
| Muffler..... | 0016 00-13 |
| | 0019 00-13 |

O

| | |
|--|--------------|
| Oil and Oil Filter, Engine | 0016 00-12 |
| Operating Instructions on Decals and Instruction Plates | 0010 00-1 |
| Operation, Theory of | 0003 00-1 |
| Operation Under Unusual Conditions..... | 0012 00-1 |
| Operation Under Usual Conditions..... | 0005 00-1 |
| | 0006 00 thru |
| | 0011 00 |
| Operator's Preventive Maintenance Checks and Services (PMCS) | 0015 00-1 |
| Outlet Hoses | 0017 00-3 |

| <u>Subject</u> | <u>WP Sequence No.-Page No.</u> |
|---|---|
| P | |
| Personnel Shower Assembly..... | 0016 00-4 0017 00-1 0018 00-2 0019 00-2 0021 00-1 |
| Plumbing Assembly..... | 0016 00-11 0017 00-3 0019 00-10 |
| Power Cable..... | 0016 00-20 0018 00-8 0019 00-22 |
| Preparation for Operation | 0006 00-1 |
| Preparation for Movement | 0011 00-1 |
| Preventive Maintenance Checks and Services (PMCS)..... | 0015 00-1 |
| Prime-Detergent Tank Assembly and Tank Lid | 0006 00-6 0019 00-5 |
| Pump Unit Canvas Protective Cover | 0018 00-3 0019 00-3 |
| Pump Unit Checklist..... | 0006 00-2 |
| Pump Unit Frame | |
| Inspection..... | 0019 00-8 |
| Service | 0019 00-8 |
| Pump Unit Subassembly..... | 0016 00-9 0019 00-8 |
| R | |
| References..... | 0026 00-1 |
| Reporting Equipment Improvement Recommendations (EIR) | 0001 00-1 |
| S | |
| Setup..... | 0005 00-3 |
| Showering..... | 0009 00-1 |
| Skid Assembly | 0016 00-20 0019 00-22 |
| Skid Base Subassembly | 0019 00-10 |
| Slurry Nozzle Assembly | 0016 00-6 0019 00-5 |
| Spraying Water from a Natural Source..... | 0007 00-1 |
| Spraying Water from Tank | 0007 00-2 |
| Starter..... | 0025 00-1 |
| Starting the M12A1 Pump Unit | 0006 00-1 |
| Stopping the M12A1 Pump Unit | 0006 00-7 |
| Stopping the Water Heater..... | 0007 00-9 |
| Suction Hose Assembly | 0016 00-16 0017 00-5 0019 00-16 |
| T | |
| Tank Drain Valve..... | 0016 00-17 0017 00-5 0019 00-17 |
| Tank Unit..... | 0016 00-16 0018 00-7 0019 00-15 |
| Theory of Operation..... | 0003 00-1 |

Subject

WP Sequence No.-Page No.

T (Cont)

Troubleshooting Procedures

| | |
|---|------------|
| Additives Fail to Mix in Solution | 0014 00-6 |
| Belts Squeal | 0014 00-5 |
| Burner Fails to Ignite | 0014 00-6 |
| Burner Ignites But No Hot Water Discharge | 0014 00-10 |
| Burner Sputters Out and Diesel Engine Stops | 0014 00-7 |
| Class III Leak in System | 0014 00-10 |
| Engine Cranks But Will Not Start | 0014 00-1 |
| Engine Fails to Start | 0014 00-1 |
| Engine Runs Irregularly | 0014 00-2 |
| Excessive Smoke Coming From Engine Exhaust During Operation | 0014 00-3 |
| Pump Inoperative (Fails to Operate) | 0014 00-3 |
| Pump Overheats or Is Noisy | 0014 00-5 |
| Pump Seal Leaks | 0014 00-5 |
| Pump Vibrates Excessively | 0014 00-4 |
| Water Not Hot Enough | 0014 00-9 |
| Water Too Hot | 0014 00-8 |

V

| | |
|---|------------|
| VALVE NO. 2 LOWER REEL and VALVE NO. 3 UPPER REEL | 0016 00-12 |
| | 0017 00-3 |
| | 0019 00-12 |
| VALVE NO.1 MANIFOLD | 0016 00-12 |
| | 0019 00-12 |

W

| | |
|---------------------------------|------------|
| Water Heater, Liquid Fuel | 0016 00-18 |
| | 0017 00-6 |
| | 0018 00-8 |
| | 0019 00-18 |
| Water Hose Assembly | 0016 00-20 |
| | 0017 00-7 |
| | 0019 00-22 |

These are the instructions for sending an electronic 2028

The following format must be used if submitting an electronic 2028. The subject line must be exactly the same and all fields must be included; however only the following fields are mandatory: 1, 3, 4, 5, 6, 7, 8, 9, 10, 13, 15, 16, 17, and 27.

From: "Whomever" <whomever@avma27.army.mil>

To: amssbriml@natick.army.mil

Subject: DA Form 2028

1. **From:** Joe Smith
2. **Unit:** home
3. **Address:** 4300 Park
4. **City:** Hometown
5. **St:** MO
6. **Zip:** 77777
7. **Date Sent:** 19-OCT-93
8. **Pub no:** 55-2840-229-23
9. **Pub Title:** TM
10. **Publication Date:** 04-JUL-85
11. **Change Number:** 7
12. **Submitter Rank:** MSG
13. **Submitter FName:** Joe
14. **Submitter MName:** T
15. **Submitter LName:** Smith
16. **Submitter Phone:** 123-123-1234
17. **Problem:** 1
18. **Page:** 2
19. **Paragraph:** 3
20. **Line:** 4
21. **NSN:** 5
22. **Reference:** 6
23. **Figure:** 7
24. **Table:** 8
25. **Item:** 9
26. **Total:** 123
27. **Text:**

This is the text for the problem below line 27.

| | | | | | | | |
|---|----------|------------|------------|--|-----------|--|--|
| RECOMMENDED CHANGES TO PUBLICATIONS AND BLANK FORMS For use of this form, see AR 25-30; the proponent agency is ODISC4. | | | | | | Use Part II (<i>reverse</i>) for Repair Parts and Special Tool Lists (RPSTL) and Supply Catalogs/Supply Manuals (SC/SM). | DATE Today's Date |
| TO: (<i>Forward to proponent of publication or form</i>) (<i>Include ZIP Code</i>) Commander, US Army Tank-automotive and Armament Command ATTN: AMSTA-LC-CECT 15 Kansas St., Natick, MA 01760 | | | | | | FROM: (<i>Activity and location</i>) (<i>Include ZIP Code</i>) Your mailing address | |
| PART I - ALL PUBLICATIONS (EXCEPT RPSTL AND SC/SM) AND BLANK FORMS | | | | | | | |
| PUBLICATION/FORM NUMBER TM 3-4230-237-10 | | | | | | DATE 30 Nov 2003 | TITLE M12A1 DED Decontaminating Apparatus |
| ITEM NO. | PAGE NO. | PARA-GRAPH | LINE NO. * | FIGURE NO. | TABLE NO. | RECOMMENDED CHANGES AND REASON <i>(Provide exact wording of recommended changes, if possible).</i> | |
| | | | | | | | |
| <i>*Reference to line numbers within the paragraph or subparagraph.</i> | | | | | | | |
| TYPED NAME, GRADE OR TITLE | | | | TELEPHONE EXCHANGE/AUTOVON, PLUS EXTENSION | | SIGNATURE | |

| | | | | | | | | | |
|---|----------|----------|-----------------------|---|------------|----------|------------------------------------|--------------------|--|
| TO: <i>(Forward direct to addressee listed in publication)</i> | | | | FROM: <i>(Activity and location) (Include ZIP Code)</i> | | | | DATE | |
| PART II – REPAIR PARTS AND SPECIAL TOOL LISTS AND SUPPLY CATALOGS/SUPPLY MANUALS | | | | | | | | | |
| PUBLICATION NUMBER | | | | | DATE | | | TITLE | |
| PAGE NO. | COLM NO. | LINE NO. | NATIONAL STOCK NUMBER | REFERENCE NO. | FIGURE NO. | ITEM NO. | TOTAL NO. OF MAJOR ITEMS SUPPORTED | RECOMMENDED ACTION | |
| SAMPLE | | | | | | | | | |
| PART III – REMARKS <i>(Any general remarks or recommendations, or suggestions for improvement of publications and blank forms. Additional blank sheets may be used if more space is needed.)</i> | | | | | | | | | |
| | | | | | | | | | |
| TYPED NAME, GRADE OR TITLE | | | | TELEPHONE EXCHANGE/AUTOVON, PLUS EXTENSION | | | SIGNATURE | | |

| | | | | | | | | | |
|---|----------|----------|-----------------------|---|------------|----------|------------------------------------|--------------------|--|
| TO: <i>(Forward direct to addressee listed in publication)</i> | | | | FROM: <i>(Activity and location) (Include ZIP Code)</i> | | | | DATE | |
| PART II - REPAIR PARTS AND SPECIAL TOOL LISTS AND SUPPLY CATALOGS/SUPPLY MANUALS | | | | | | | | | |
| PUBLICATION NUMBER | | | | | DATE | | | TITLE | |
| PAGE NO. | COLM NO. | LINE NO. | NATIONAL STOCK NUMBER | REFERENCE NO. | FIGURE NO. | ITEM NO. | TOTAL NO. OF MAJOR ITEMS SUPPORTED | RECOMMENDED ACTION | |
| | | | | | | | | | |
| PART III - REMARKS <i>(Any general remarks or recommendations, or suggestions for improvement of publications and blank forms. Additional blank sheets may be used if more space is needed.)</i> | | | | | | | | | |
| | | | | | | | | | |
| TYPED NAME, GRADE OR TITLE | | | | TELEPHONE EXCHANGE/AUTOVON, PLUS EXTENSION | | | | SIGNATURE | |

| | | | | | | | | | |
|---|----------|----------|-----------------------|--|------------|----------|------------------------------------|--------------------|--|
| TO: <i>(Forward direct to addressee listed in publication)</i> | | | | FROM: <i>(Activity and location) (Include ZIP Code)</i> | | | | DATE | |
| PART II – REPAIR PARTS AND SPECIAL TOOL LISTS AND SUPPLY CATALOGS/SUPPLY MANUALS | | | | | | | | | |
| PUBLICATION NUMBER | | | | | DATE | | | TITLE | |
| PAGE NO. | COLM NO. | LINE NO. | NATIONAL STOCK NUMBER | REFERENCE NO. | FIGURE NO. | ITEM NO. | TOTAL NO. OF MAJOR ITEMS SUPPORTED | RECOMMENDED ACTION | |
| | | | | | | | | | |
| PART III – REMARKS <i>(Any general remarks or recommendations, or suggestions for improvement of publications and blank forms. Additional blank sheets may be used if more space is needed.)</i> | | | | | | | | | |
| | | | | | | | | | |
| TYPED NAME, GRADE OR TITLE | | | | TELEPHONE EXCHANGE/AUTOVON, PLUS EXTENSION | | | | SIGNATURE | |

| | | | | | | | | | |
|---|----------|----------|-----------------------|--|------------|----------|------------------------------------|--------------------|--|
| TO: <i>(Forward direct to addressee listed in publication)</i> | | | | FROM: <i>(Activity and location) (Include ZIP Code)</i> | | | | DATE | |
| PART II – REPAIR PARTS AND SPECIAL TOOL LISTS AND SUPPLY CATALOGS/SUPPLY MANUALS | | | | | | | | | |
| PUBLICATION NUMBER | | | | | DATE | | | TITLE | |
| PAGE NO. | COLM NO. | LINE NO. | NATIONAL STOCK NUMBER | REFERENCE NO. | FIGURE NO. | ITEM NO. | TOTAL NO. OF MAJOR ITEMS SUPPORTED | RECOMMENDED ACTION | |
| | | | | | | | | | |
| PART III – REMARKS <i>(Any general remarks or recommendations, or suggestions for improvement of publications and blank forms. Additional blank sheets may be used if more space is needed.)</i> | | | | | | | | | |
| | | | | | | | | | |
| TYPED NAME, GRADE OR TITLE | | | | TELEPHONE EXCHANGE/AUTOVON, PLUS EXTENSION | | | | SIGNATURE | |

By Order of the Secretary of the Army:

By Order of the Secretary of the Army:

Official:



JOEL B. HUDSON

*Administrative Assistant to the
Secretary of the Army*

0330001

PETER J. SCHOOMAKER
General, United States Army
Chief of Staff

Distribution: To be distributed in accordance with initial distribution number (IDN) 280893 requirements for TM 3-4230-273-10.

